

SH NO.	TITLE
1)	INDEX
2)	HARNESS ARCHITECTURE ( BLOCK DIAGRAM )
3)	LOCATION OF MAJOR COMPONENTS
4)	LOCATION OF MAJOR COMPONENTS
5)	MAIN CAB
6)	MAIN CAB ( CONTINUED )
7)	MAIN CAB ( CONTINUED )
8)	MAIN CAB ( CONTINUED )
9)	MAIN CAB ( CONTINUED )
10)	MAIN CAB ( CONTINUED )
11)	MAIN CAB ( CONTINUED )
12)	MAIN CAB ( CONTINUED )
13)	MAIN CAB ( CONTINUED )
14)	MAIN CAB ( CONTINUED )
15)	MAIN CAB ( CONTINUED )
16)	ROOF
17)	CAB AUDIO DASH
18)	CAB AUDIO ROOF
19)	CAB AUDIO EHD
20)	DOOR HARNESS ( LEFT )
21)	DOOR HARNESS ( RIGHT )
22)	70" SLEEPER
23)	70" SLEEPER LOAD CENTER WO LVD
24)	70" SLEEPER LOAD CENTER W/ LVD
25)	63" HIGH ROOF SLEEPER BOX
26)	63" LOW ROOF SLEEPER BOX
27)	63 / 48" LOAD CENTER WO LVD
28)	63 / 48" LOAD CENTER W/ LVD
29)	48" HIGH ROOF SLEEPER
30)	48" LOW ROOF SLEEPER BOX
31)	36" SLEEPER BOX
32)	36" LOAD CENTER WO LVD
33)	36" LOAD CENTER W/ LVD
34)	SLEEPER AUDIO - 36"
35)	SLEEPER AUDIO - 48 / 63 / 70"
36)	VORAD CAB HARNESS
37)	VORAD CHASSIS HARNESS
38)	TRAILER HARNESS
39)	CHASSIS HARNESS
40)	FIREWALL HARNESS
41)	HOOD HARNESS
42)	HOOD HARNESS
43)	ABS CHASSIS
44)	C15 ENGINE
45)	C13 ENGINE
46)	C9 ENGINE
47)	ISX ENGINE
48)	ISM ENGINE
49)	ISL ENGINE
50)	C9 / C13 / C15 CHARGE / START
51)	ENGINE BRAKE
52)	ISX CHARGE / START
53)	ISM CHARGE / START
54)	ISC / ISL CHARGE / START
55)	CAT FUSE HARNESS
56)	CUMMINS FUSE HARNESS
57)	XMSN - ALLISON DASH
58)	XMSN - ALLISON DASH ( CONTINUED )
59)	XMSN - ALLISON DASH ( CONTINUED )
60)	XMSN - ALLISON DASH ( CONTINUED )
61)	XMSN - ALLISON CHASSIS
62)	XMSN - AUTOSHIFT DASH
63)	XMSN - AUTO / ULTRA XMSN
64)	XMSN - ULTRASHIFT DASH
65)	XMSN - ULTRASHIFT W/ VORAD DASH
66)	XMSN - ULTRASHIFT W/ VORAD XMSN

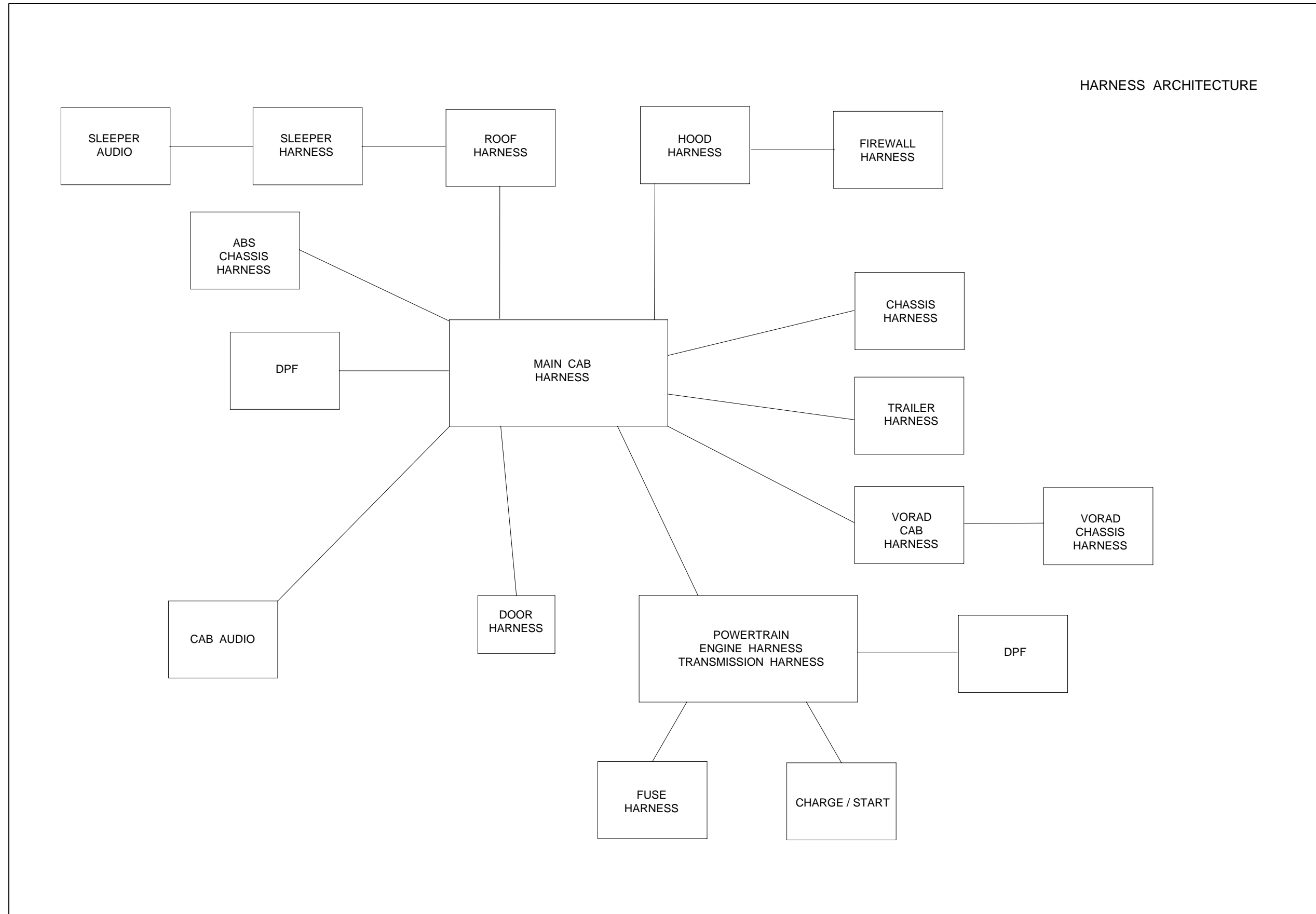

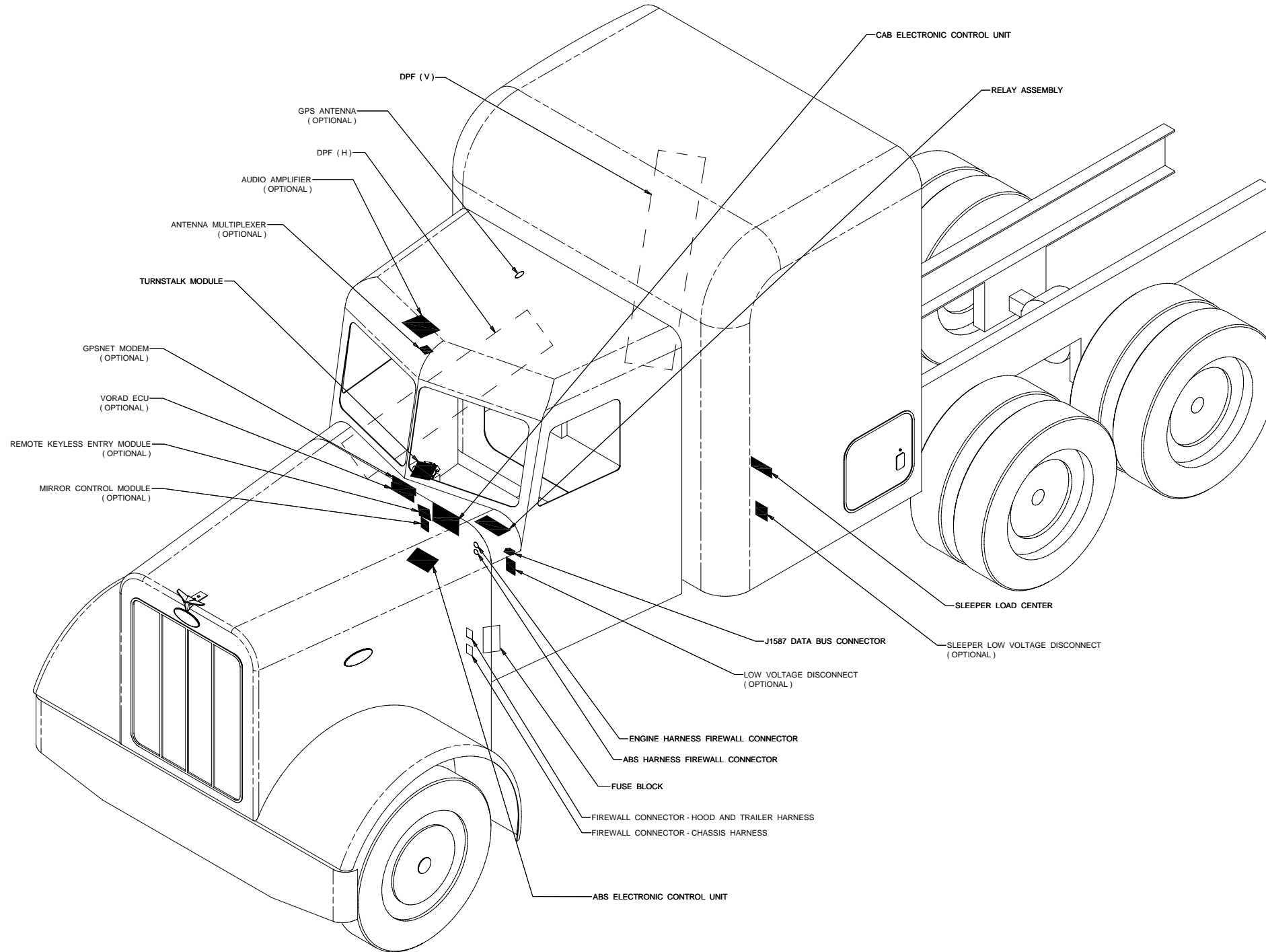

LOCATION OF MAJOR COMPONENTS



LOCATION OF MAJOR COMPONENTS

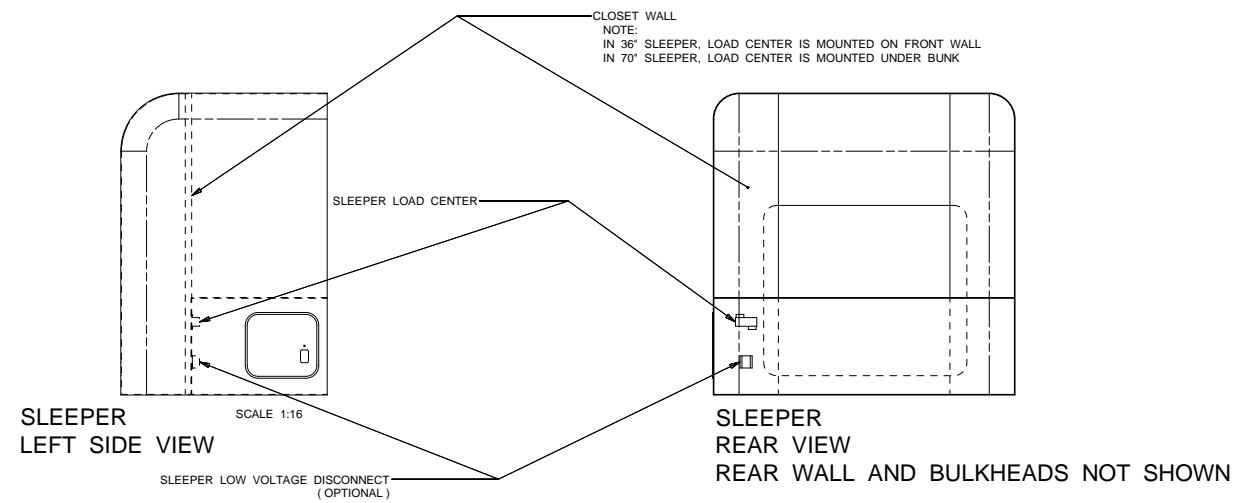
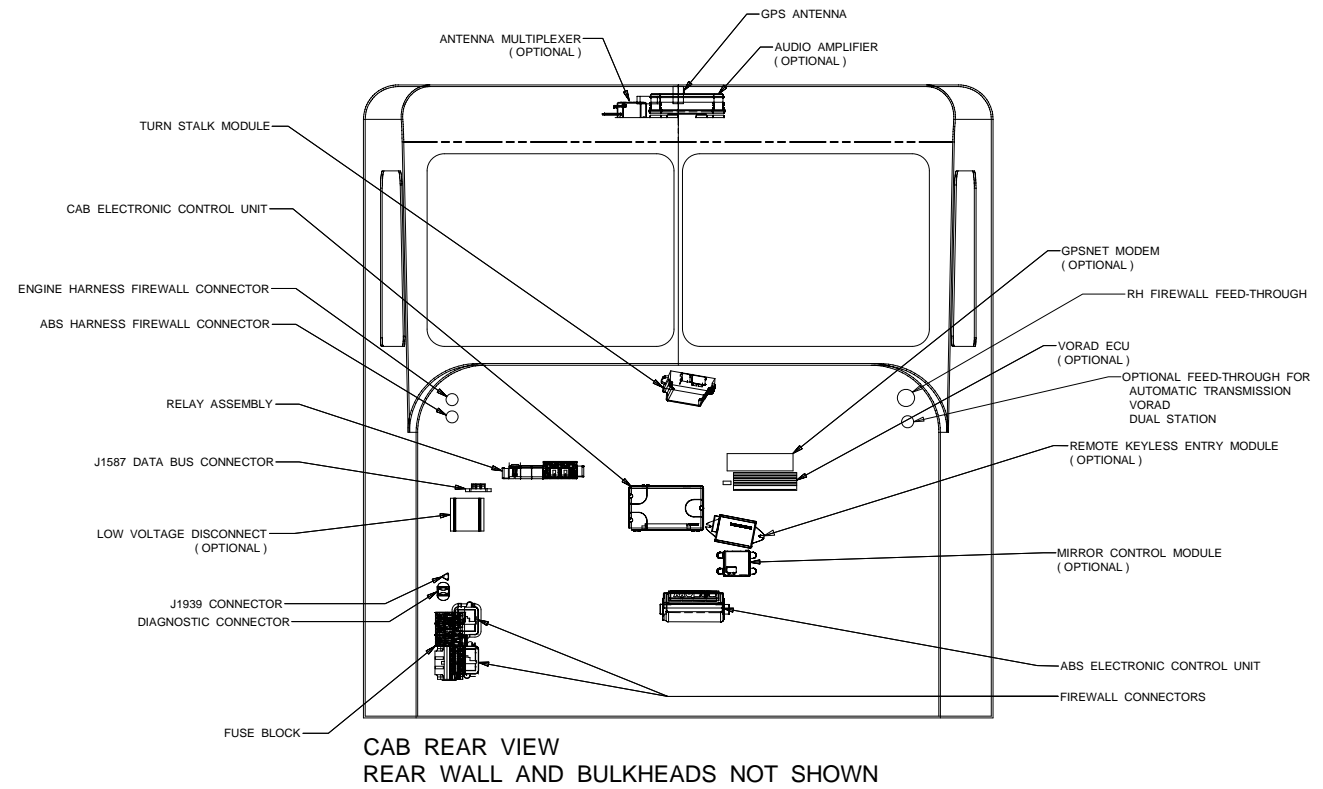
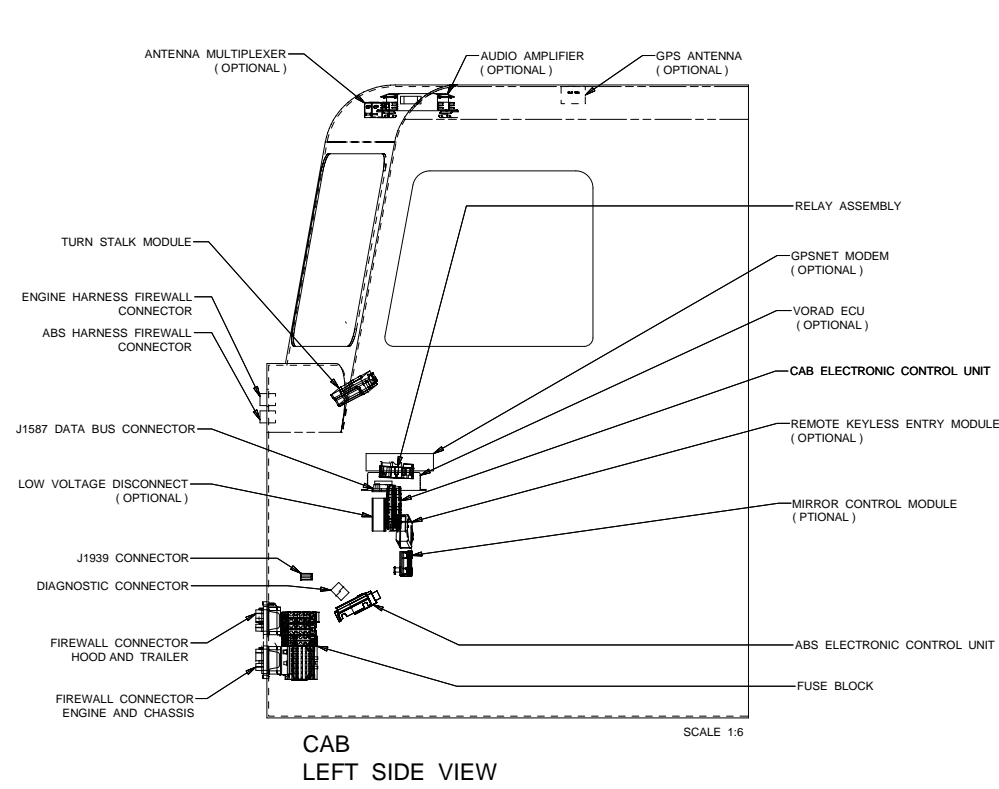

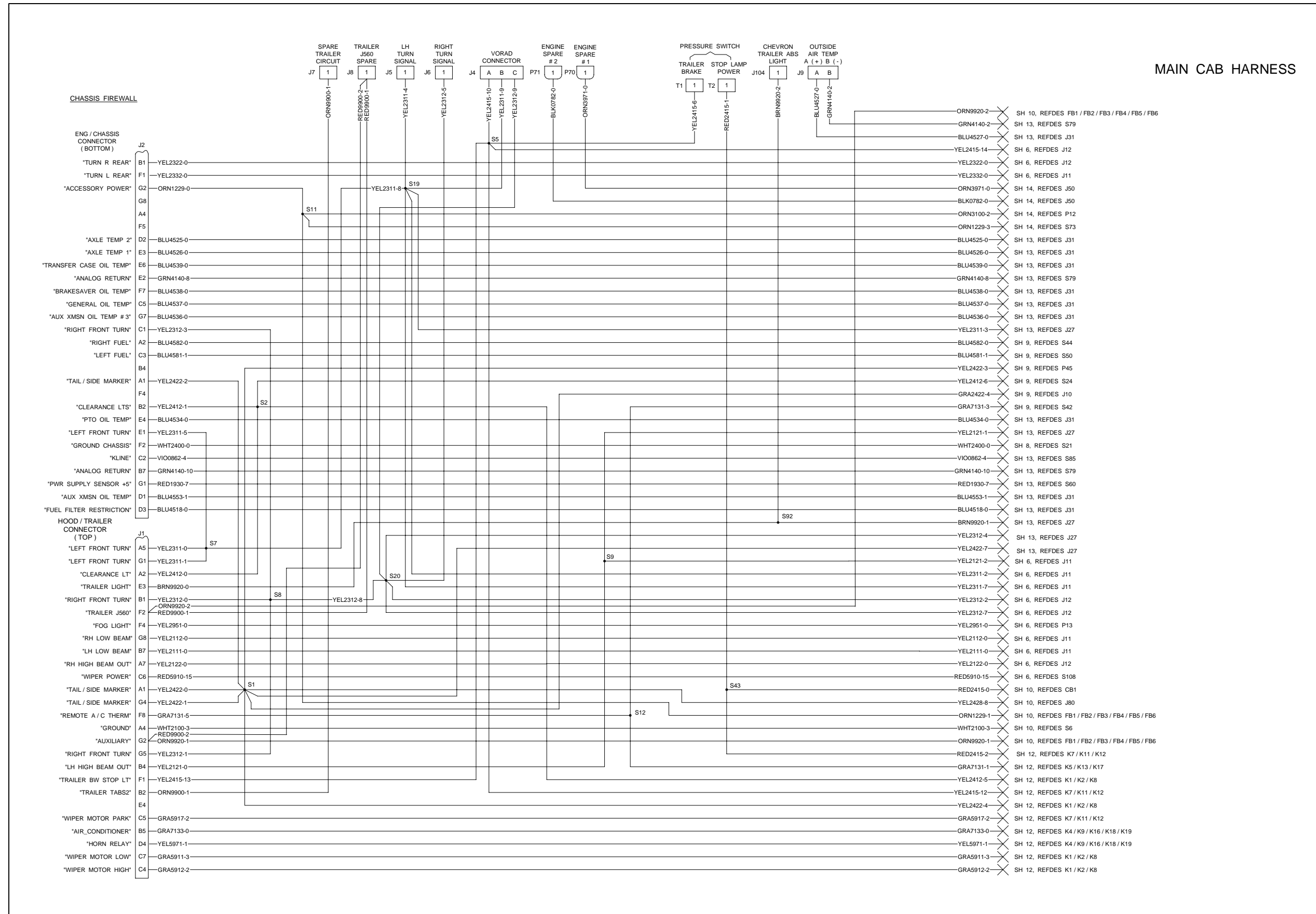

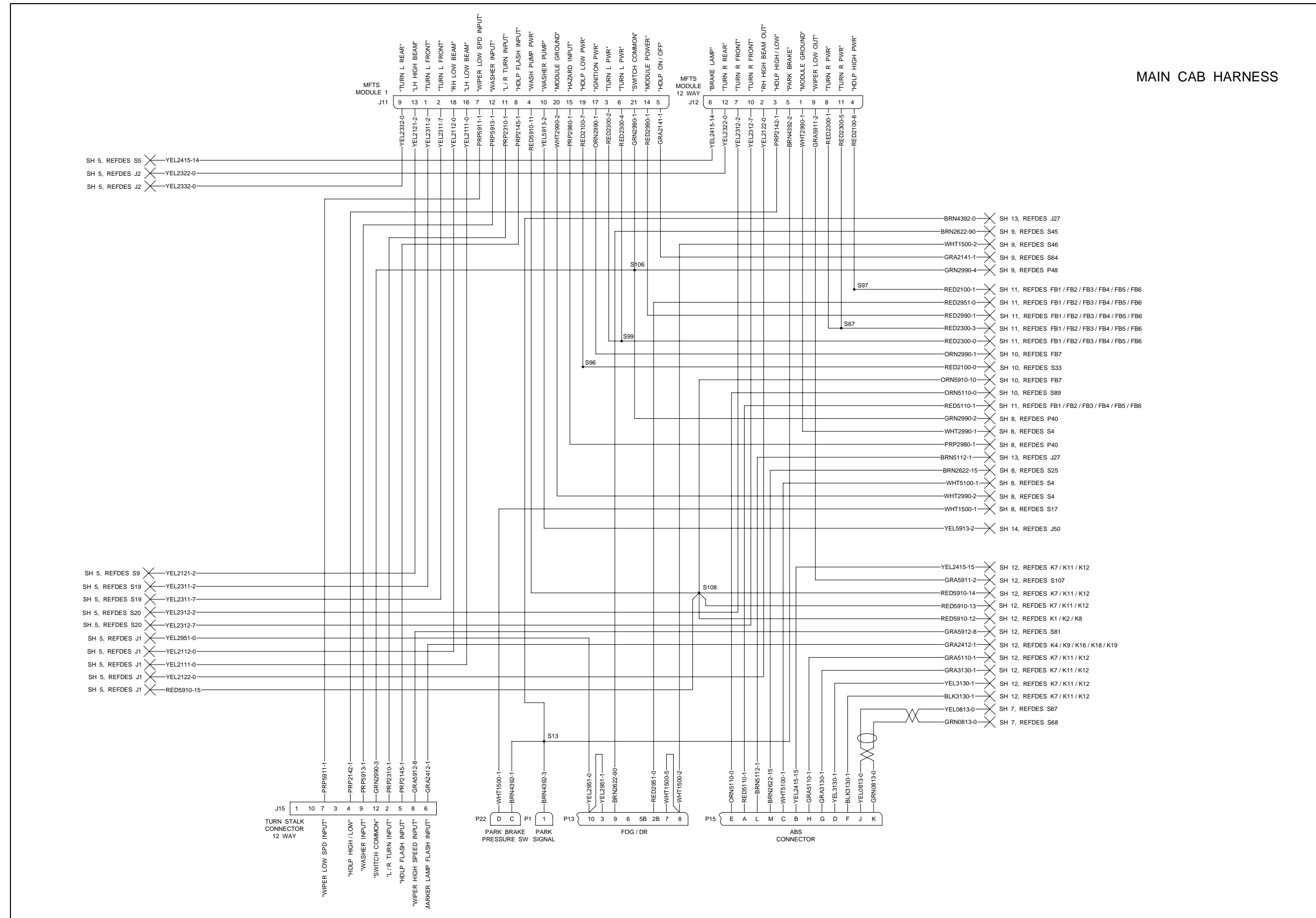



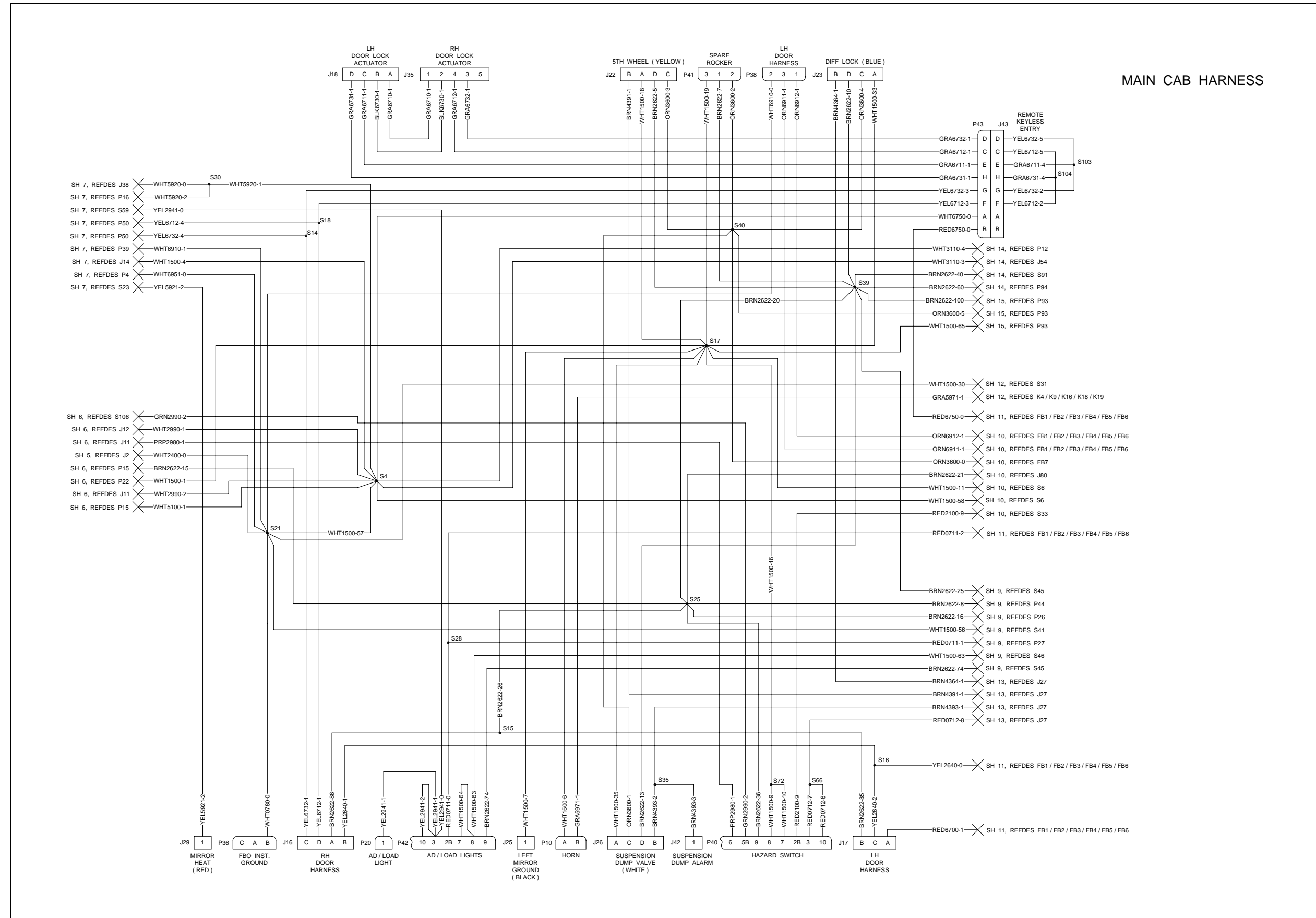



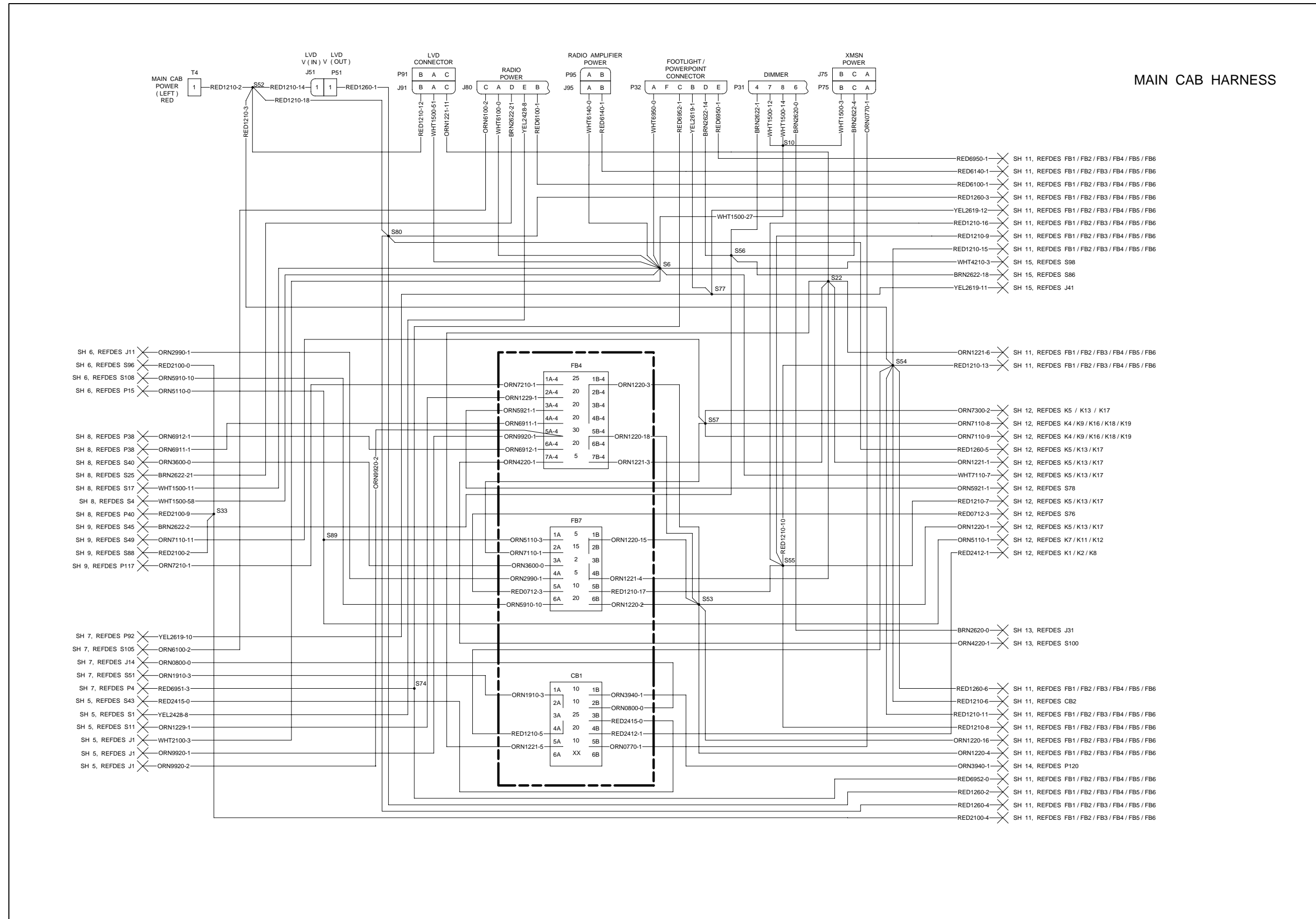

MAIN CAB HARNESS

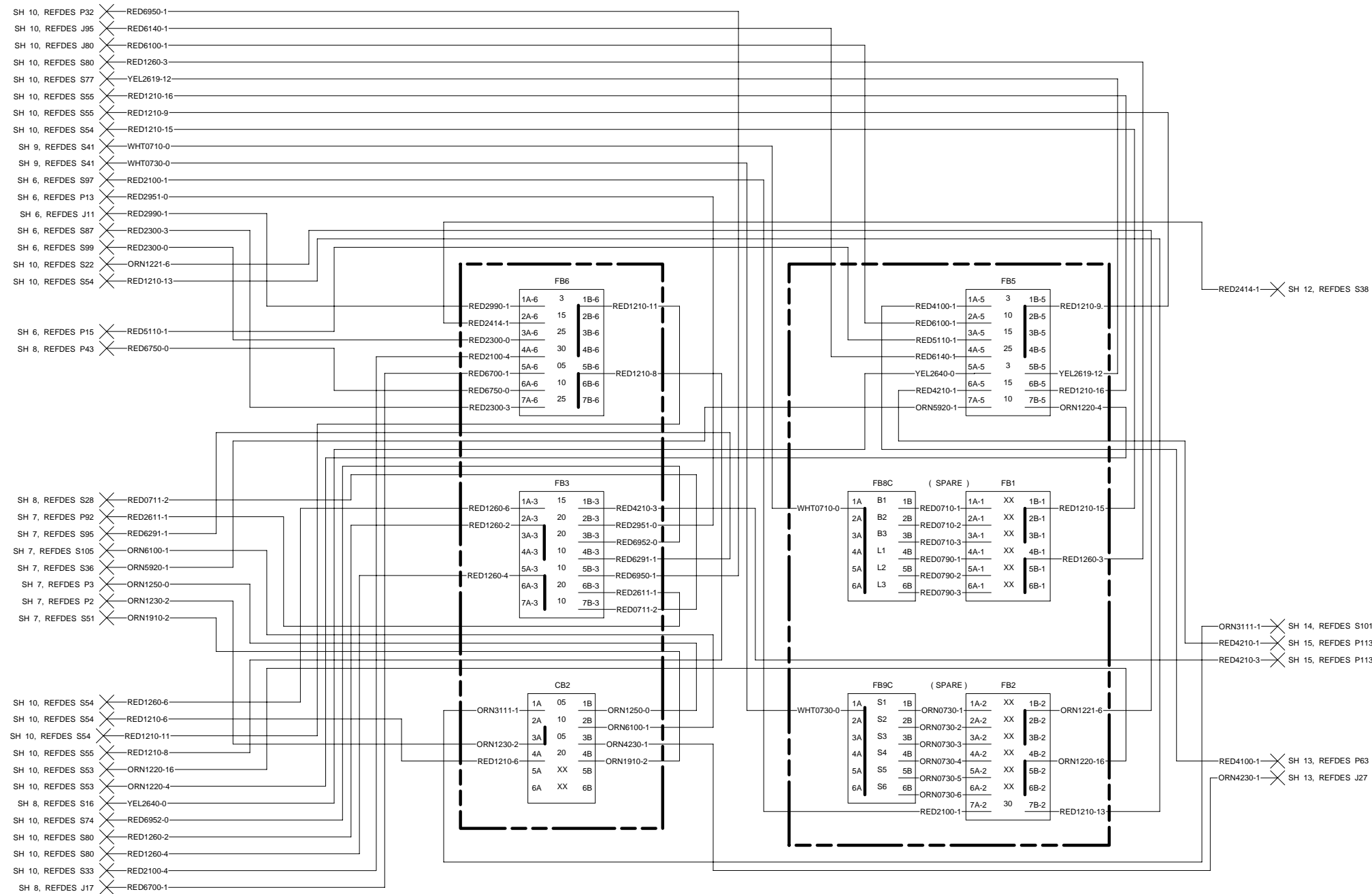

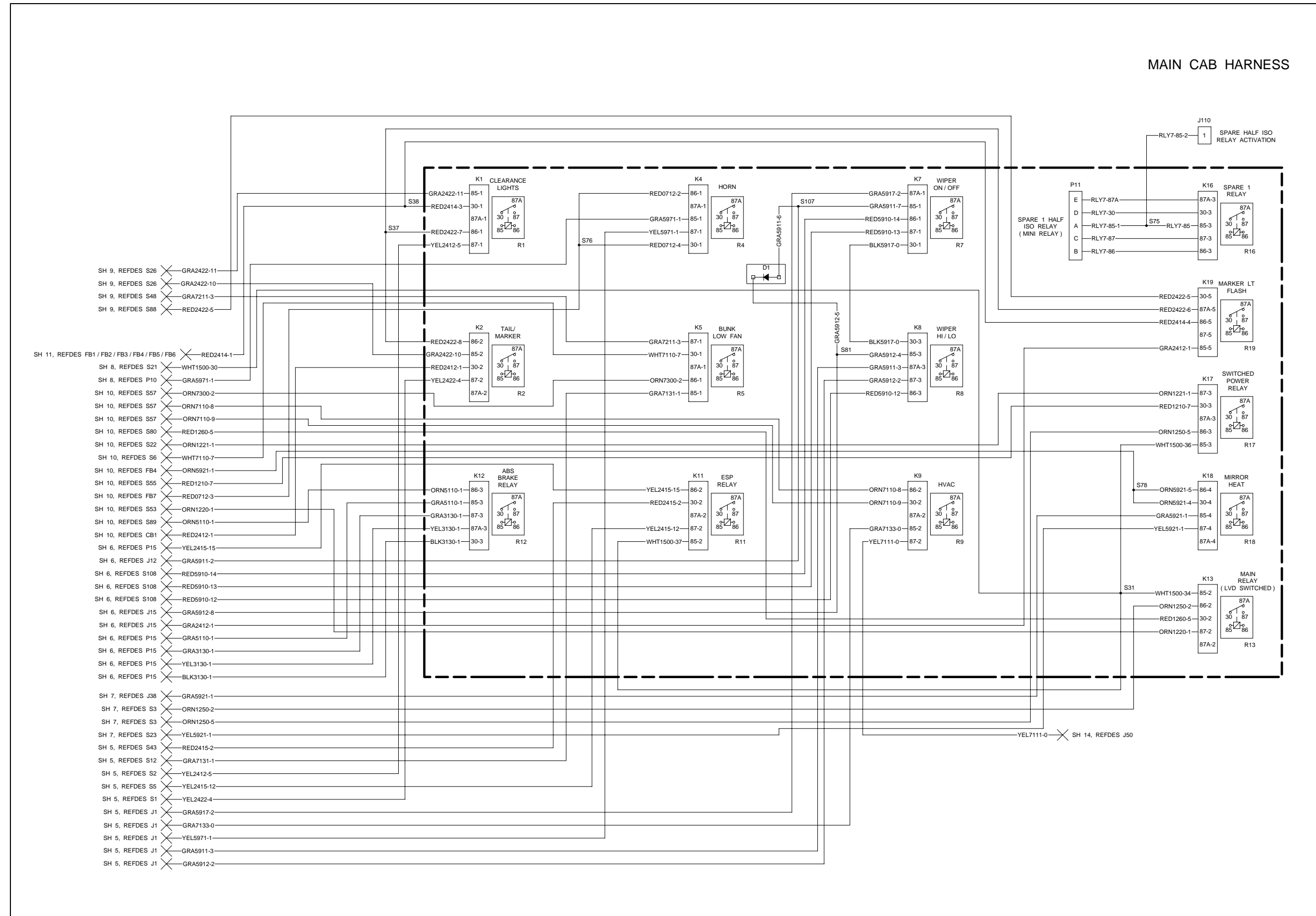

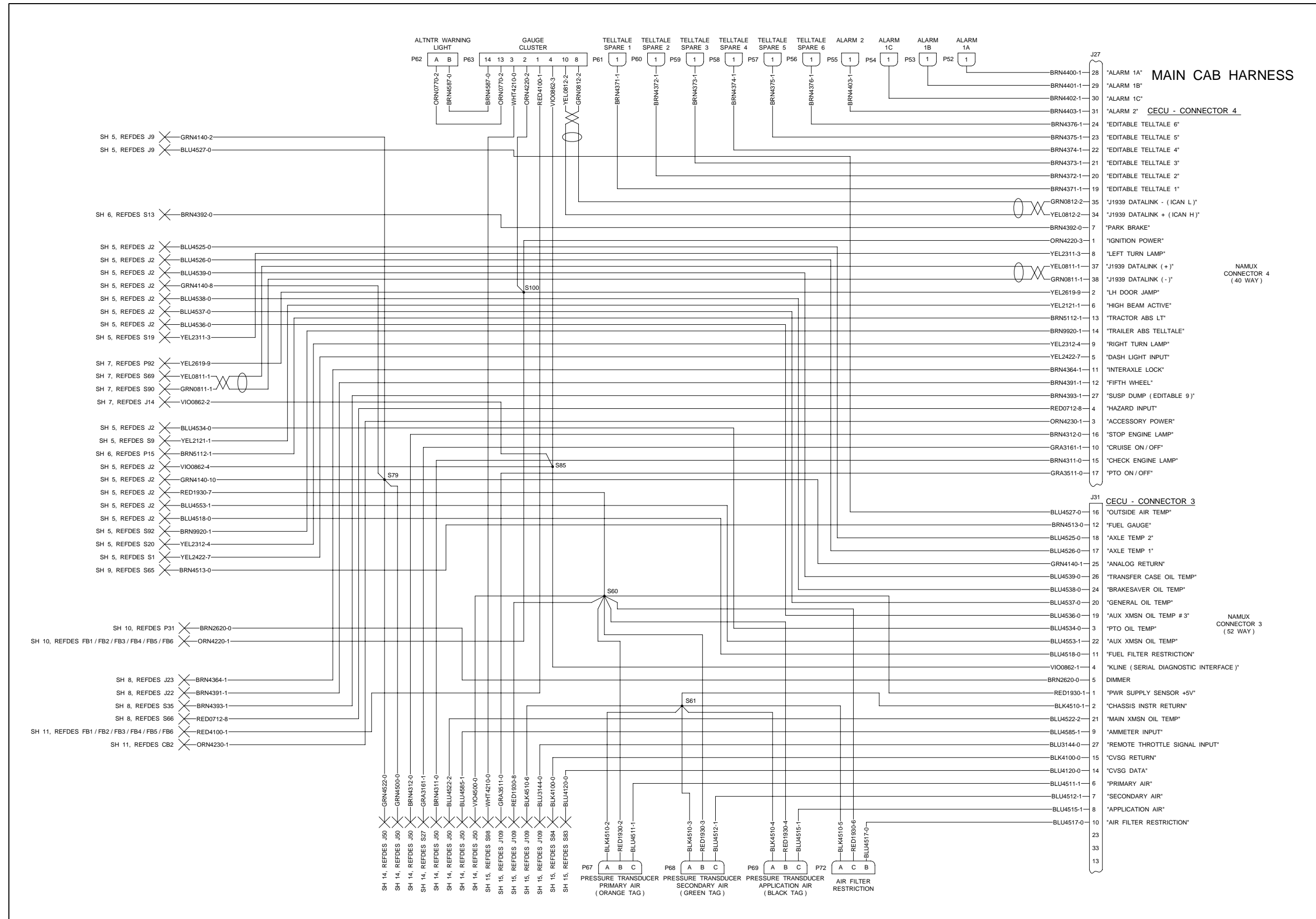

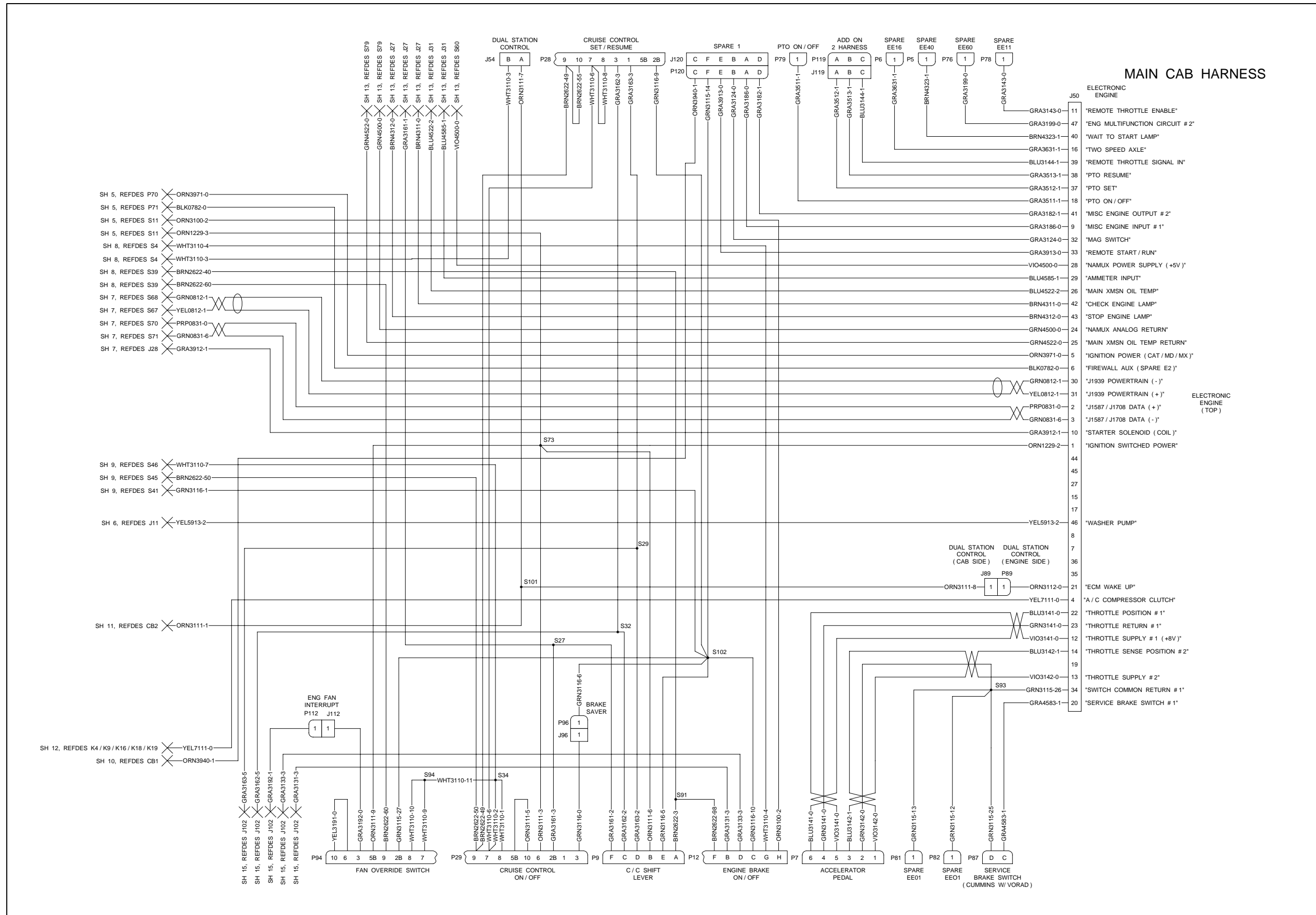





AUDIO HARNESS

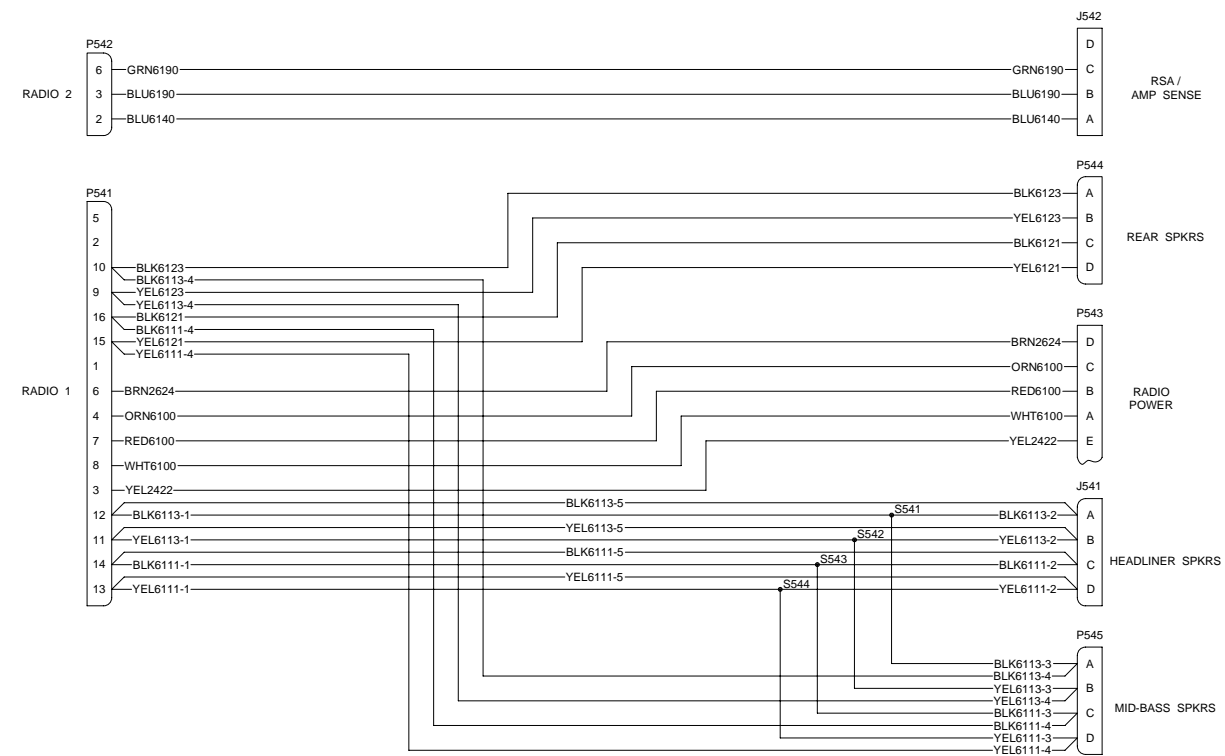

AUDIO HARNESS  
(ROOF)

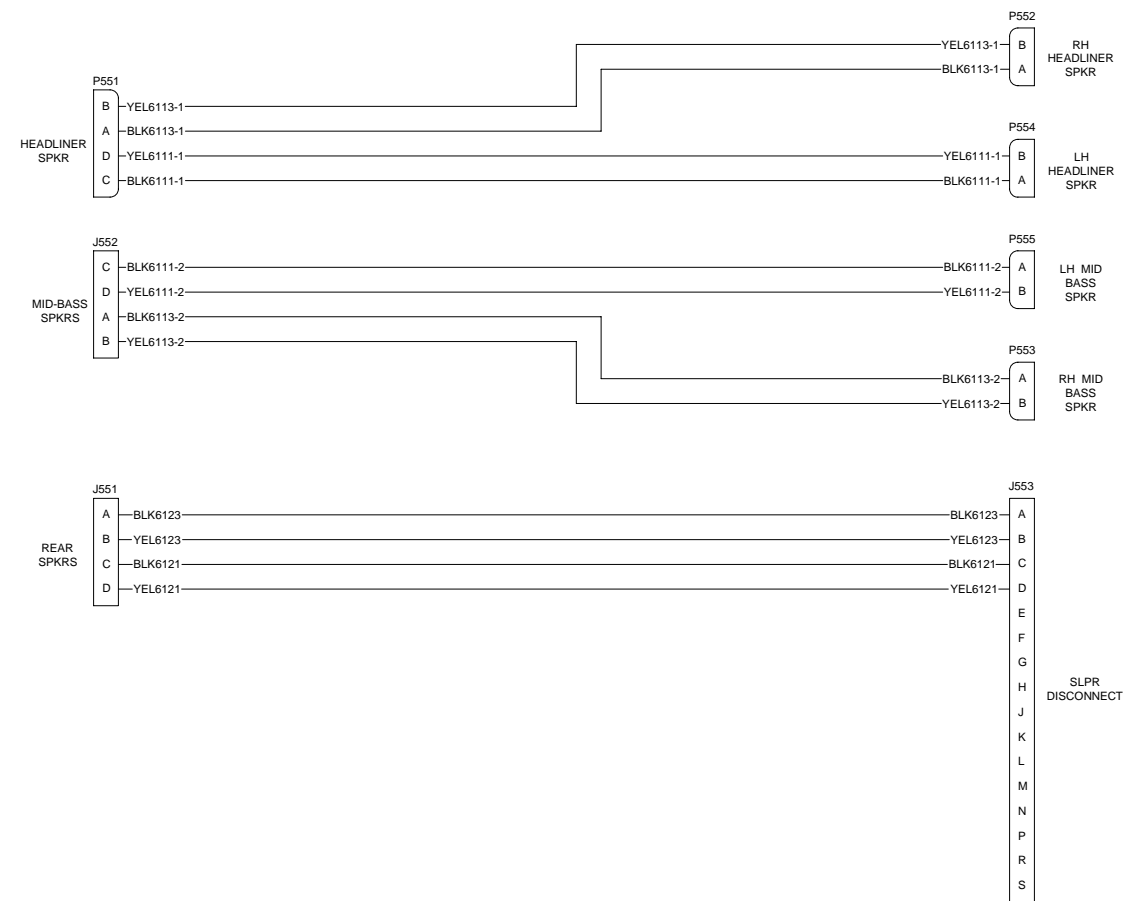

AUDIO HARNESS  
PLATINUM EHD  
(ROOF)

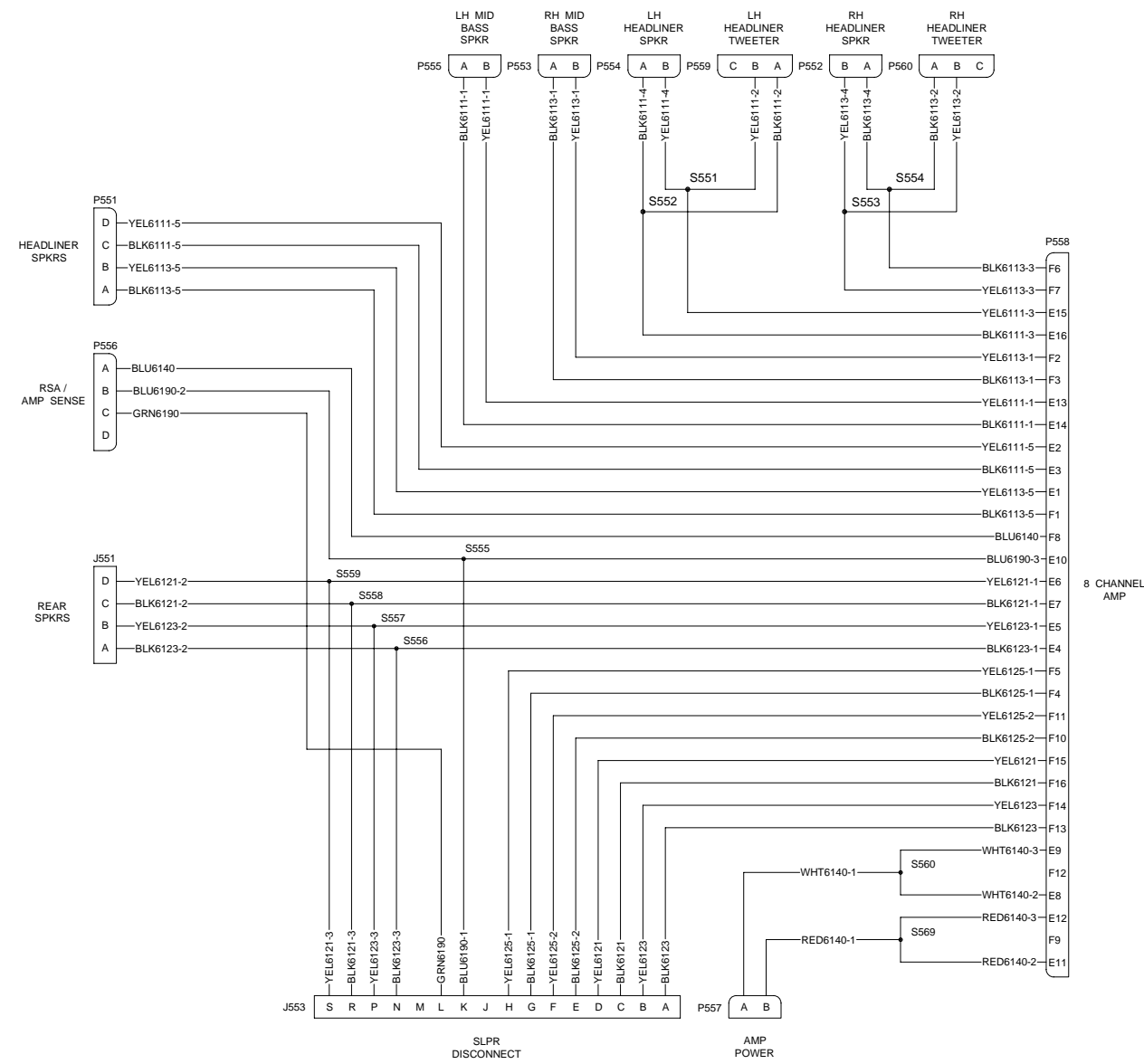

DOOR HARNESS (LEFT)

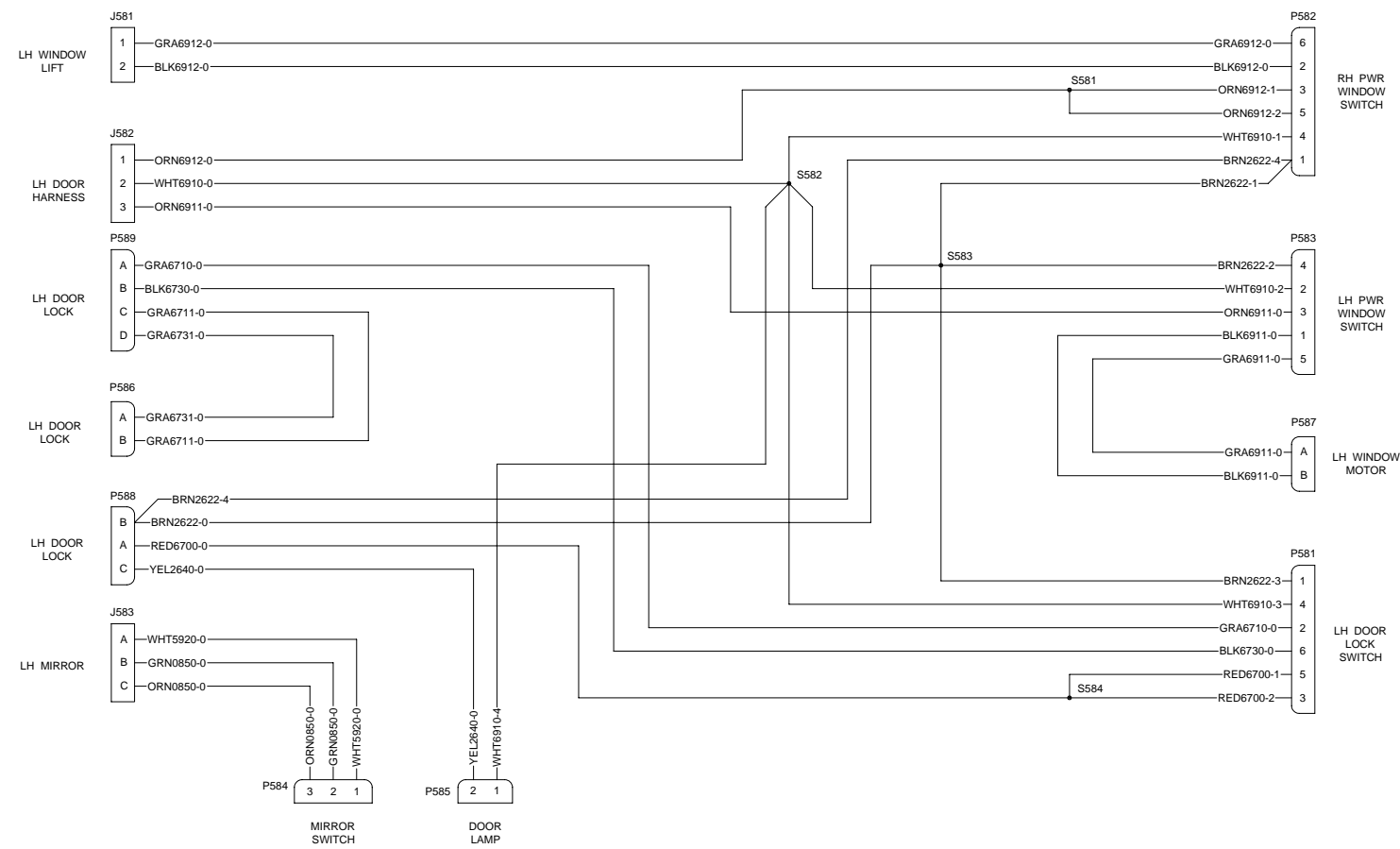

DOOR HARNESS ( RIGHT )

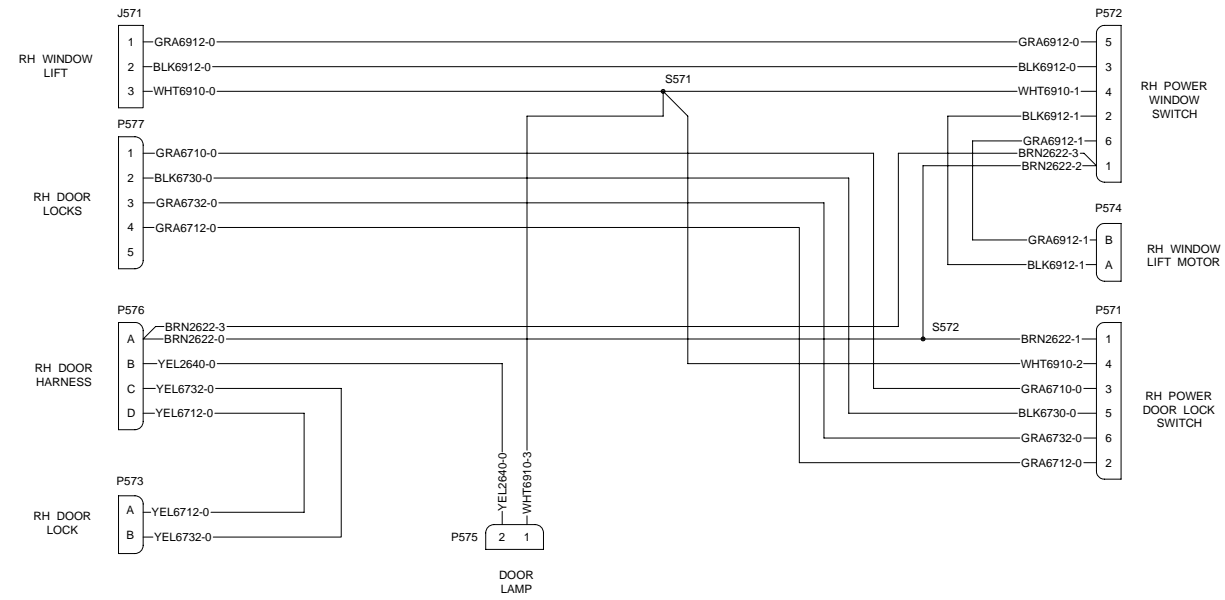

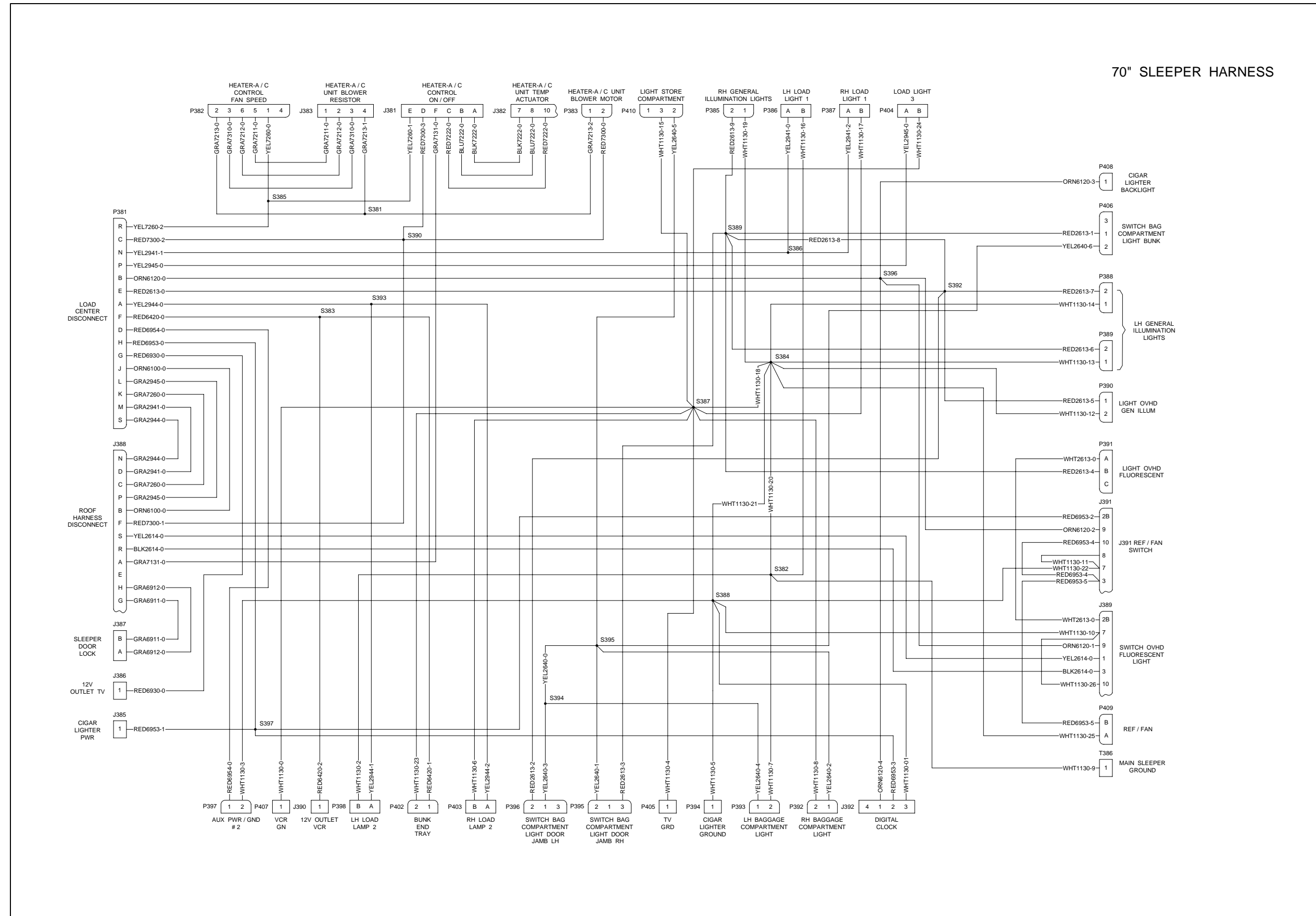

70" SLEEPER LOAD CENTER  
WO LVD

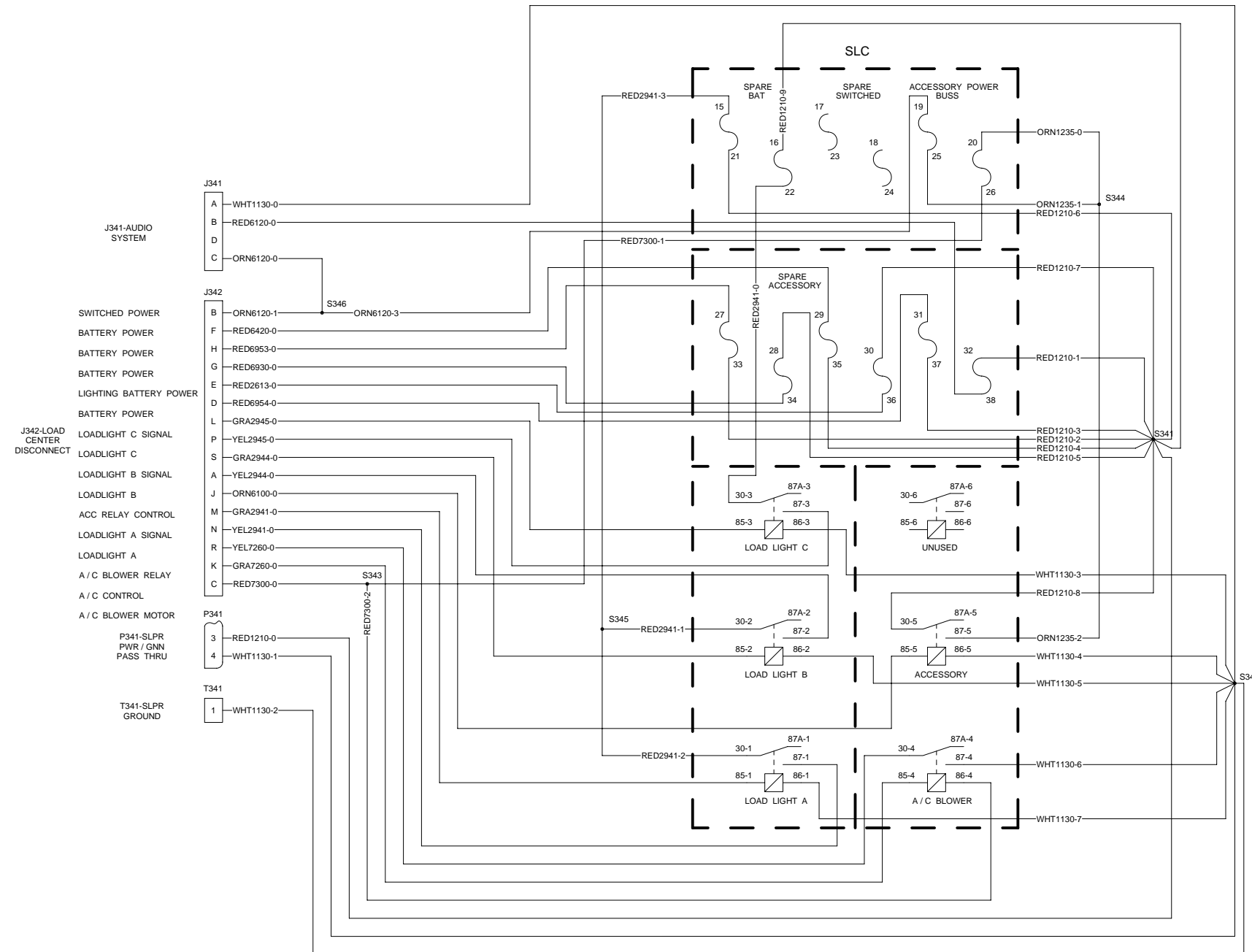

70" SLEEPER LOAD CENTER  
W/ LVD

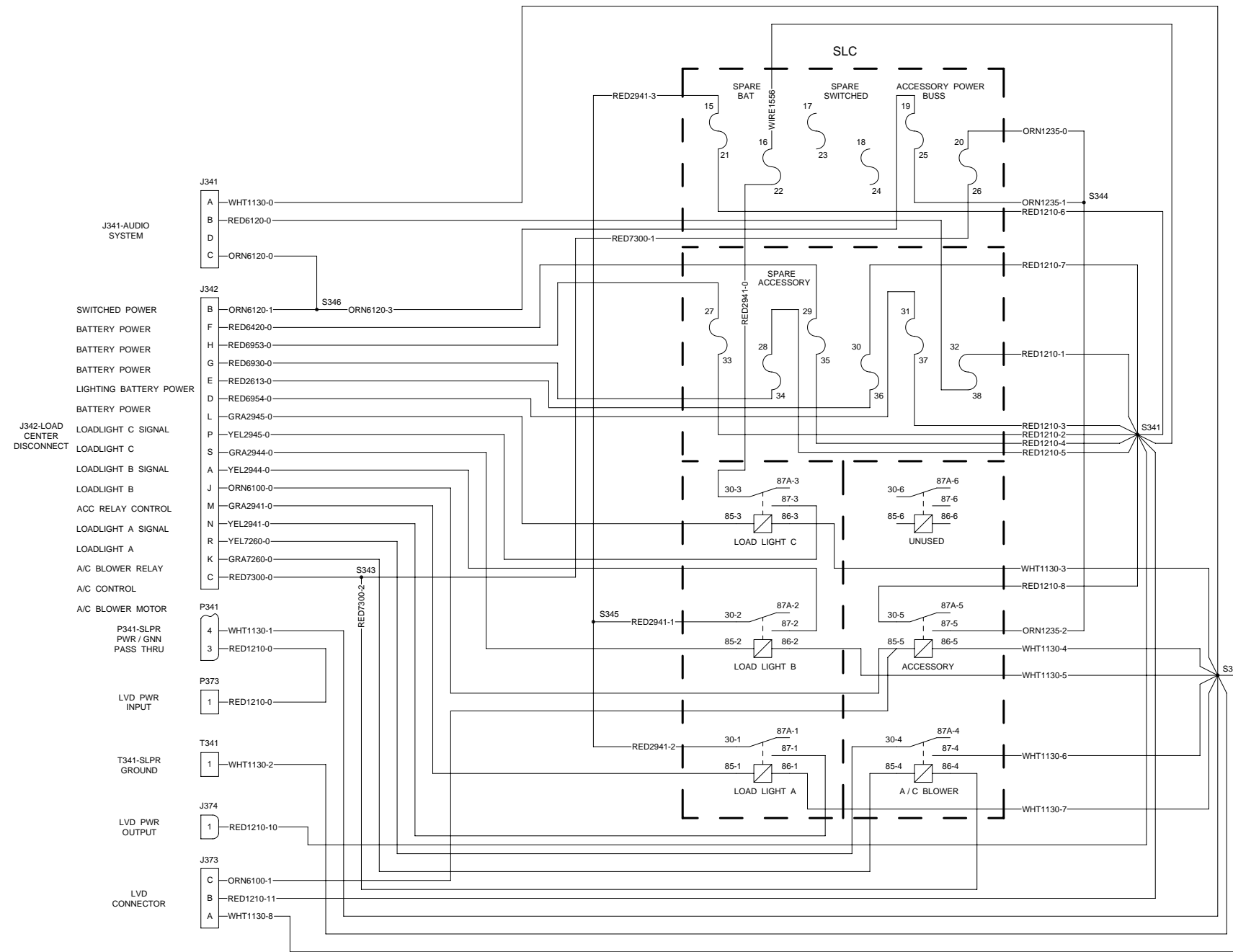

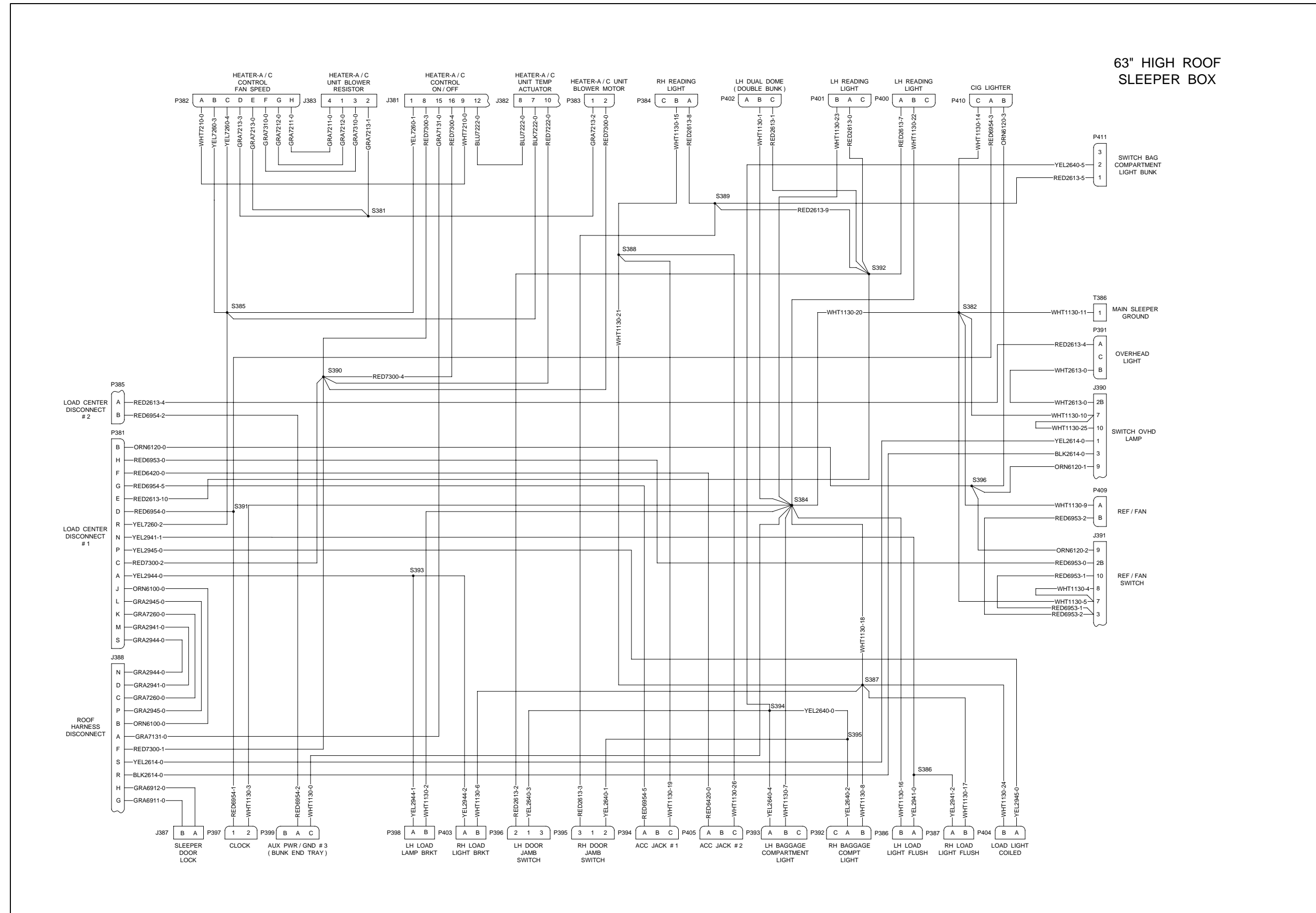

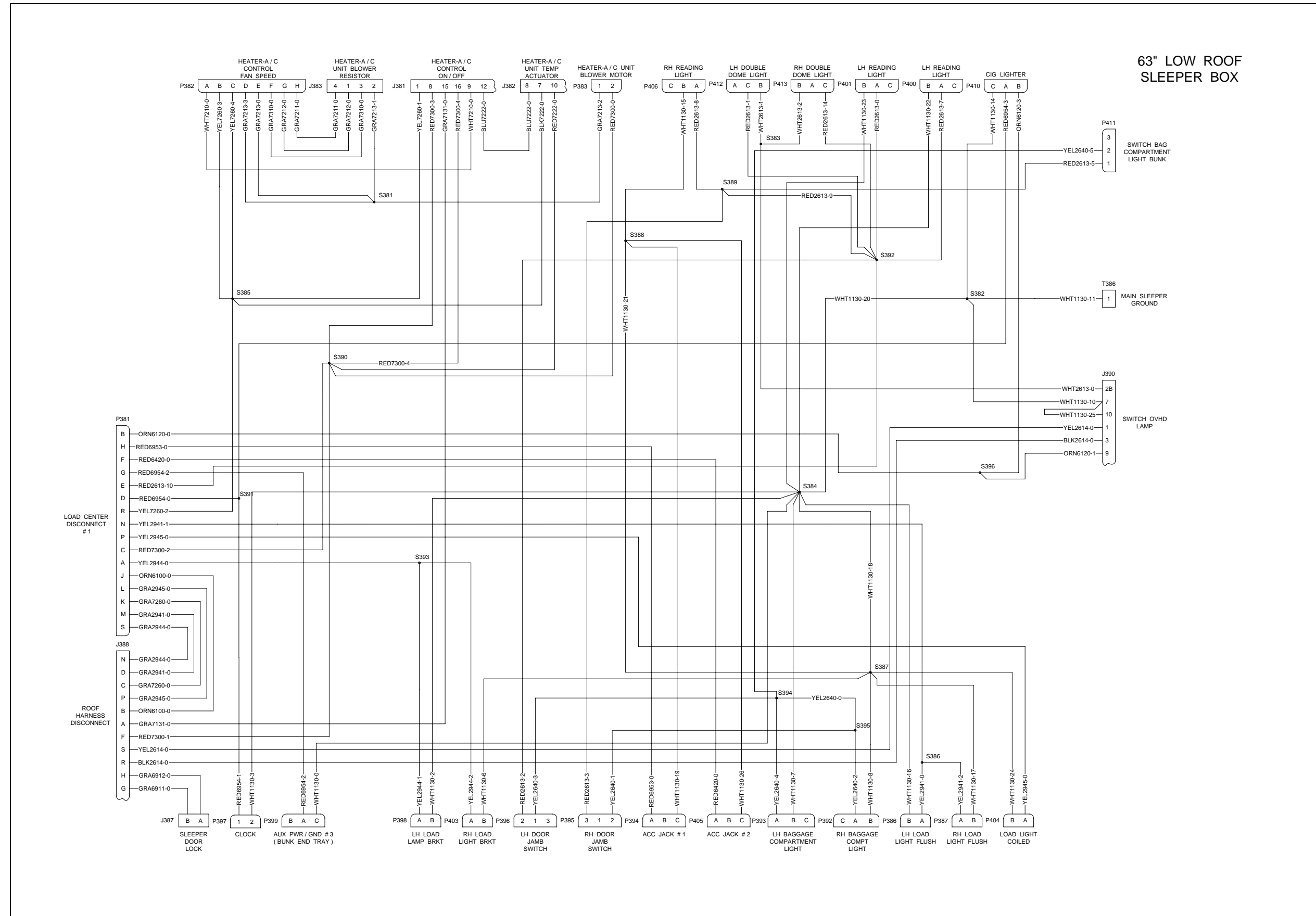

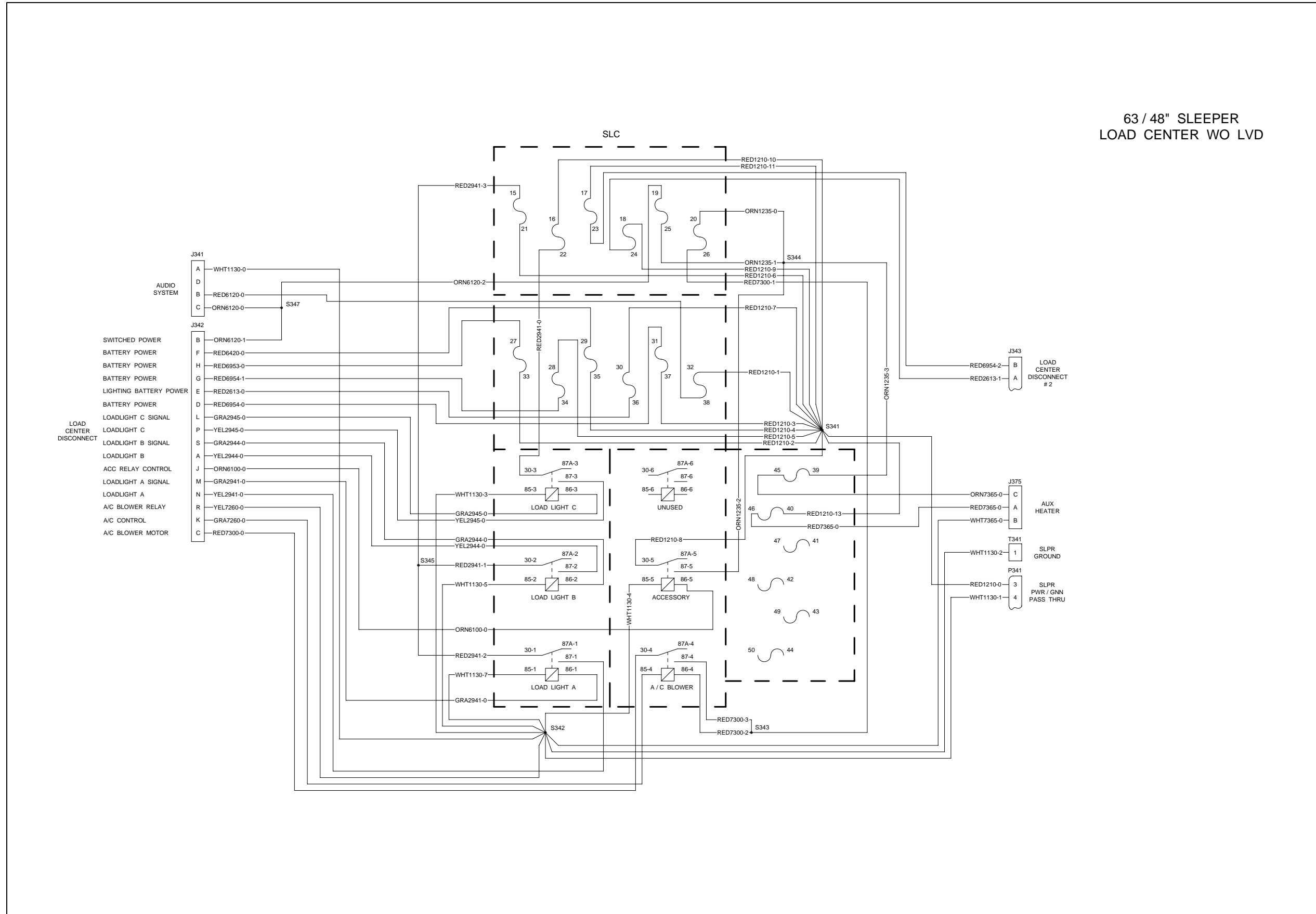

63 / 48" SLEEPER  
LOAD CENTER W/LVD

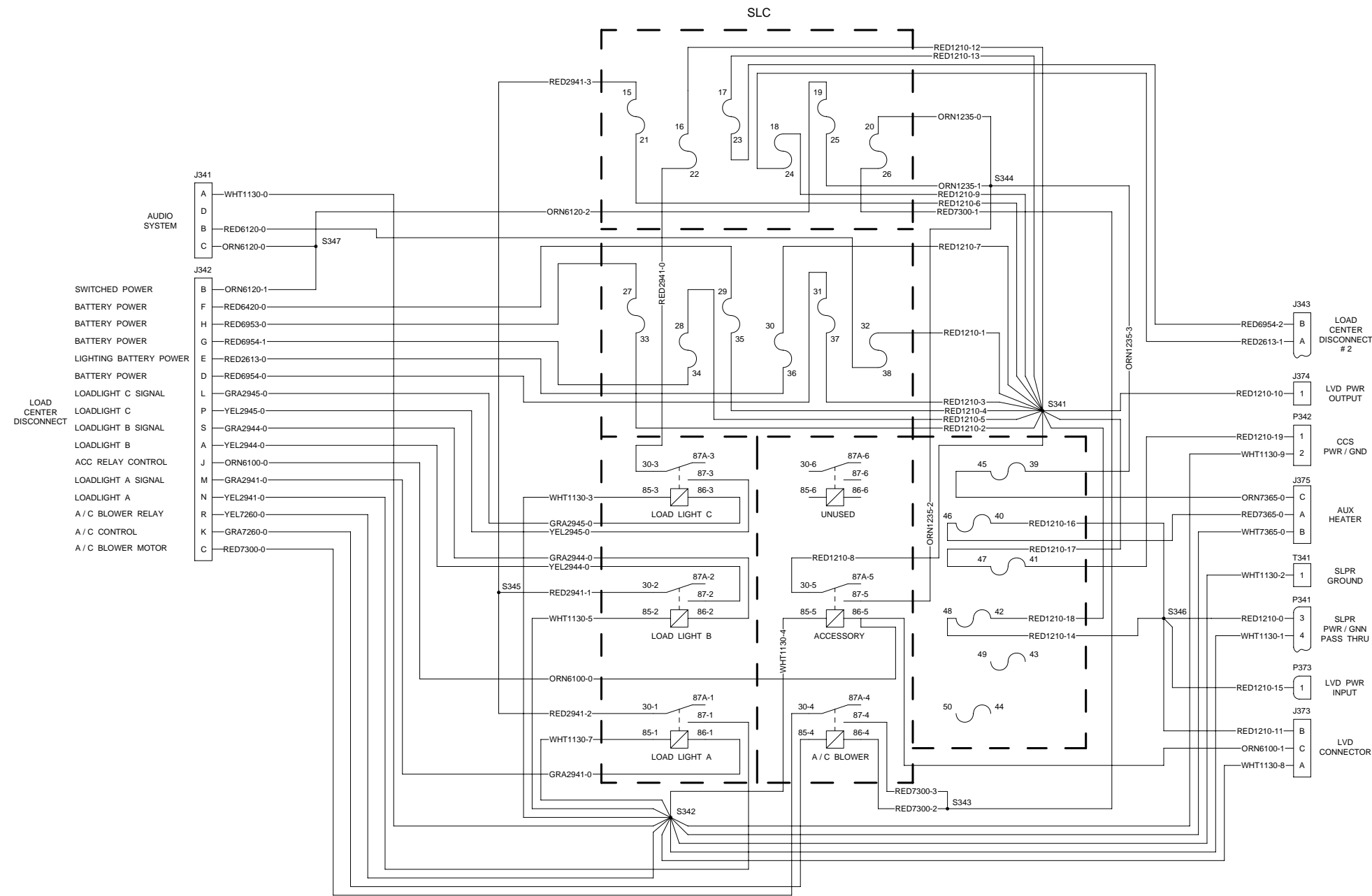

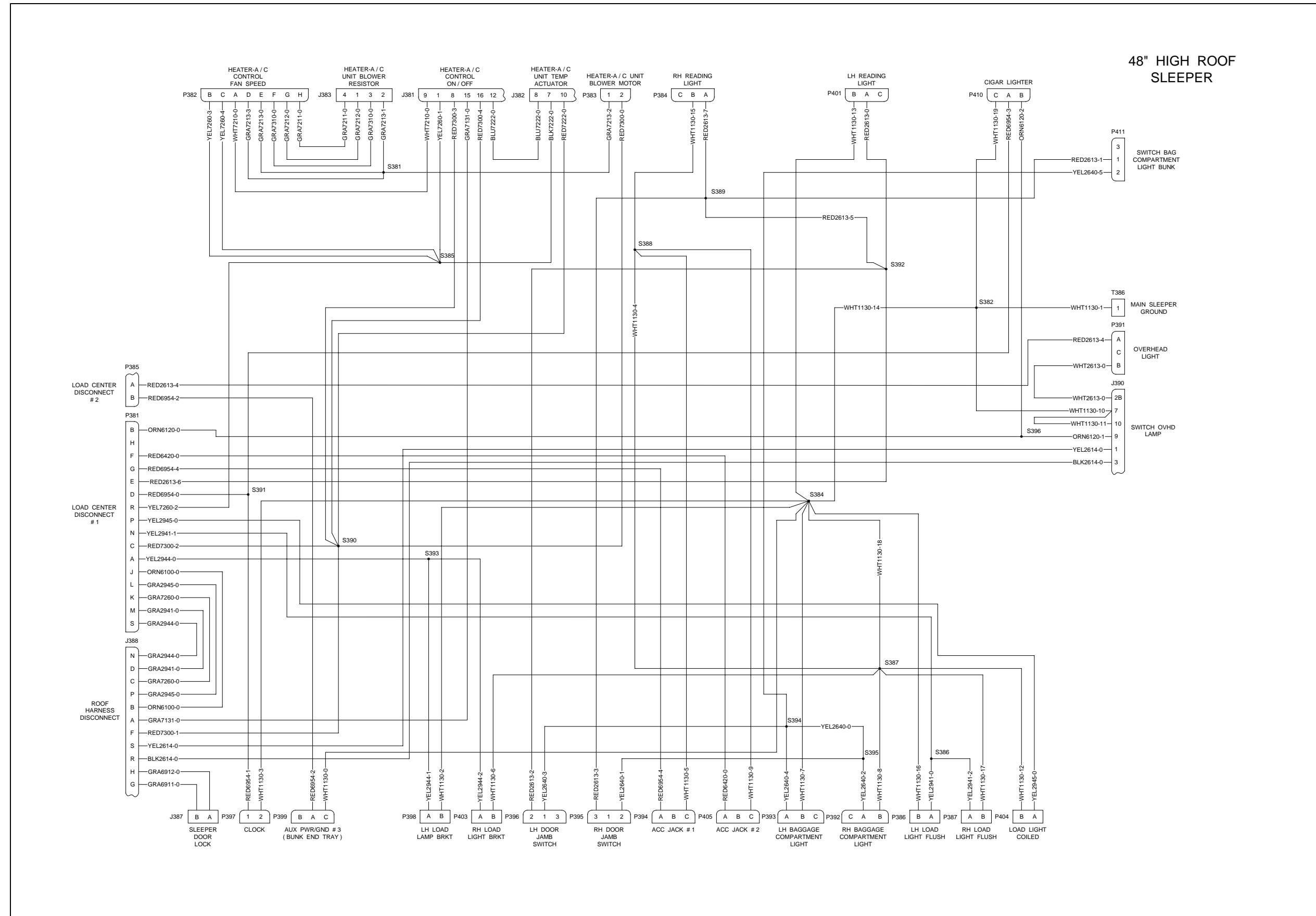

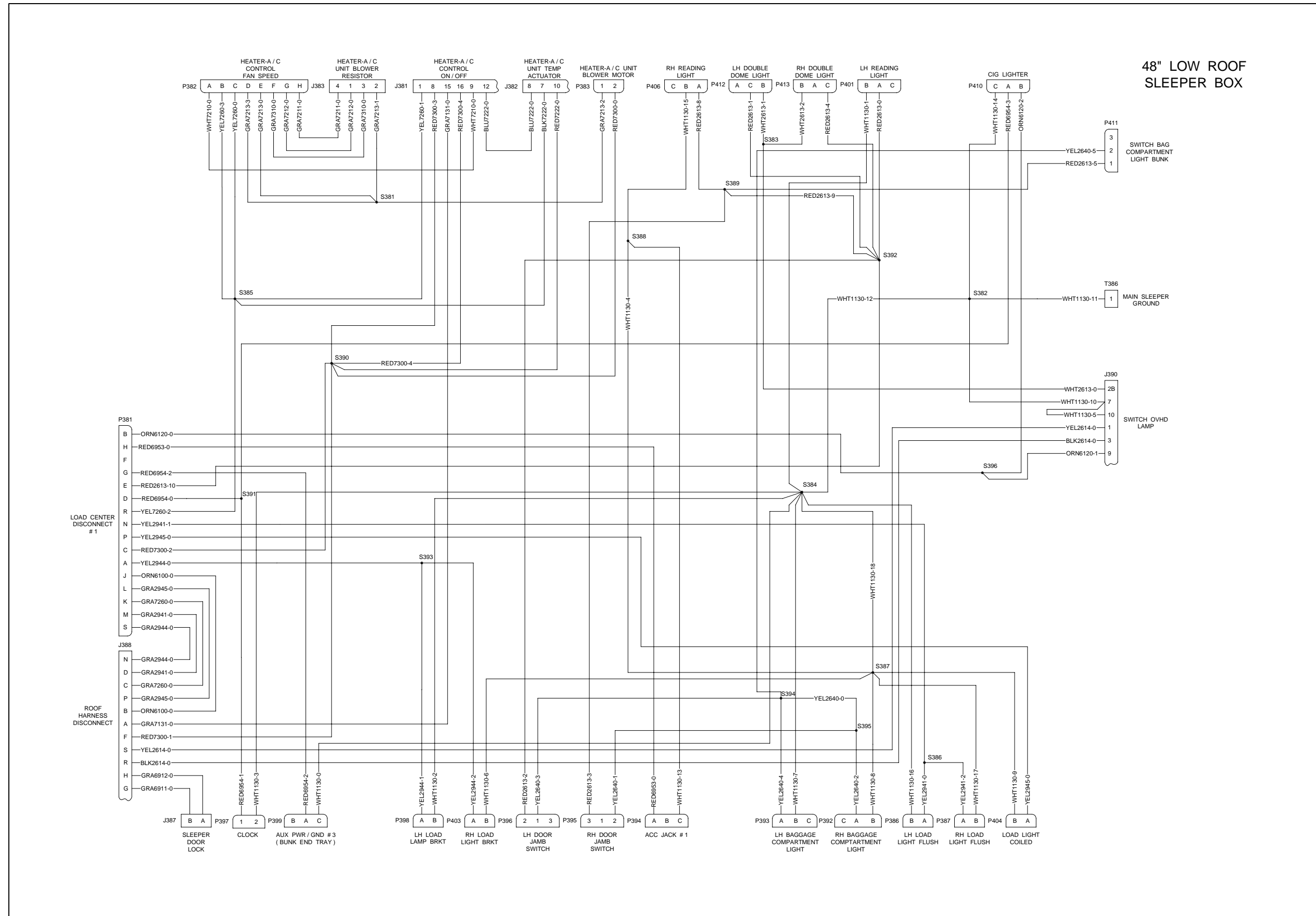

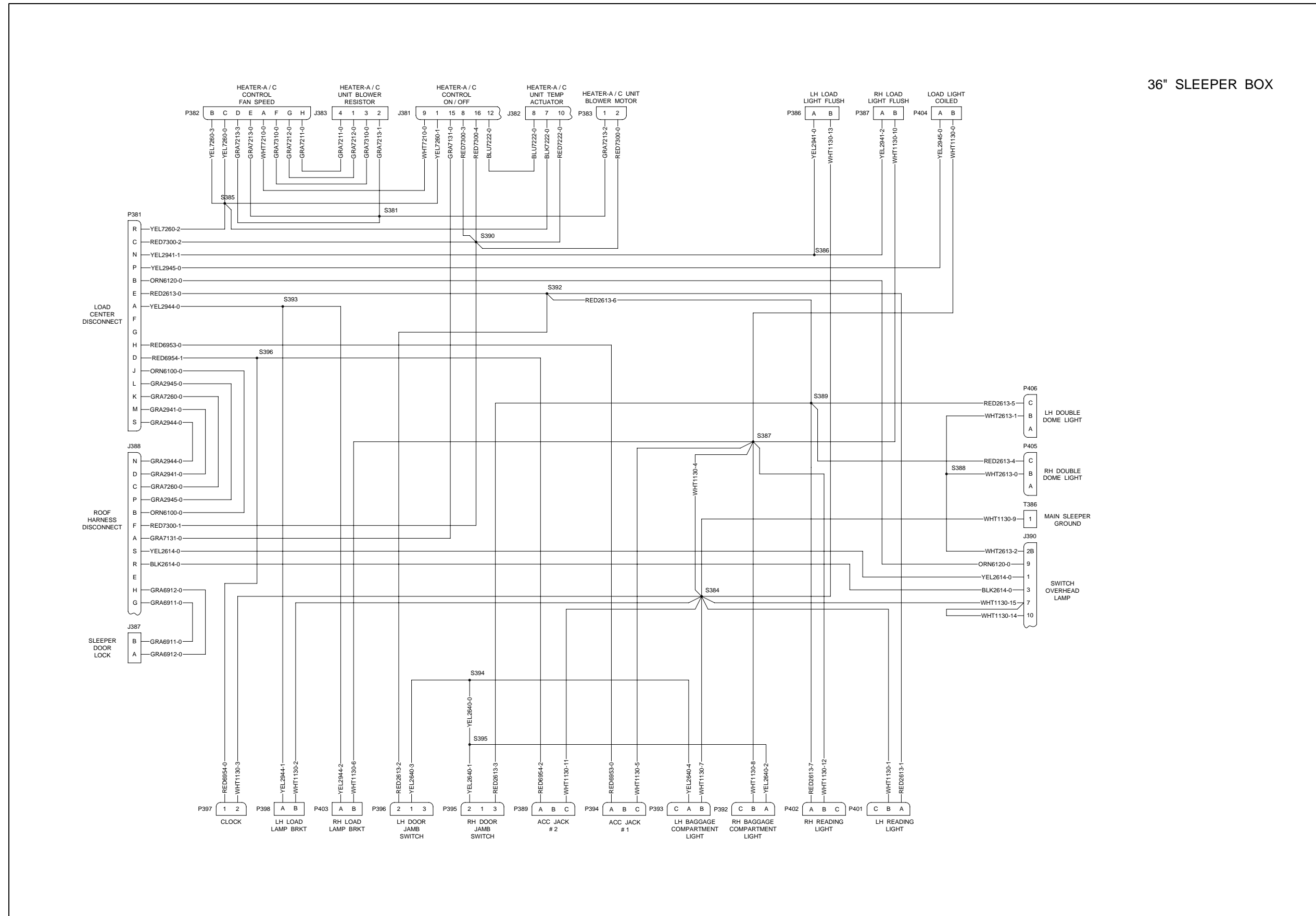

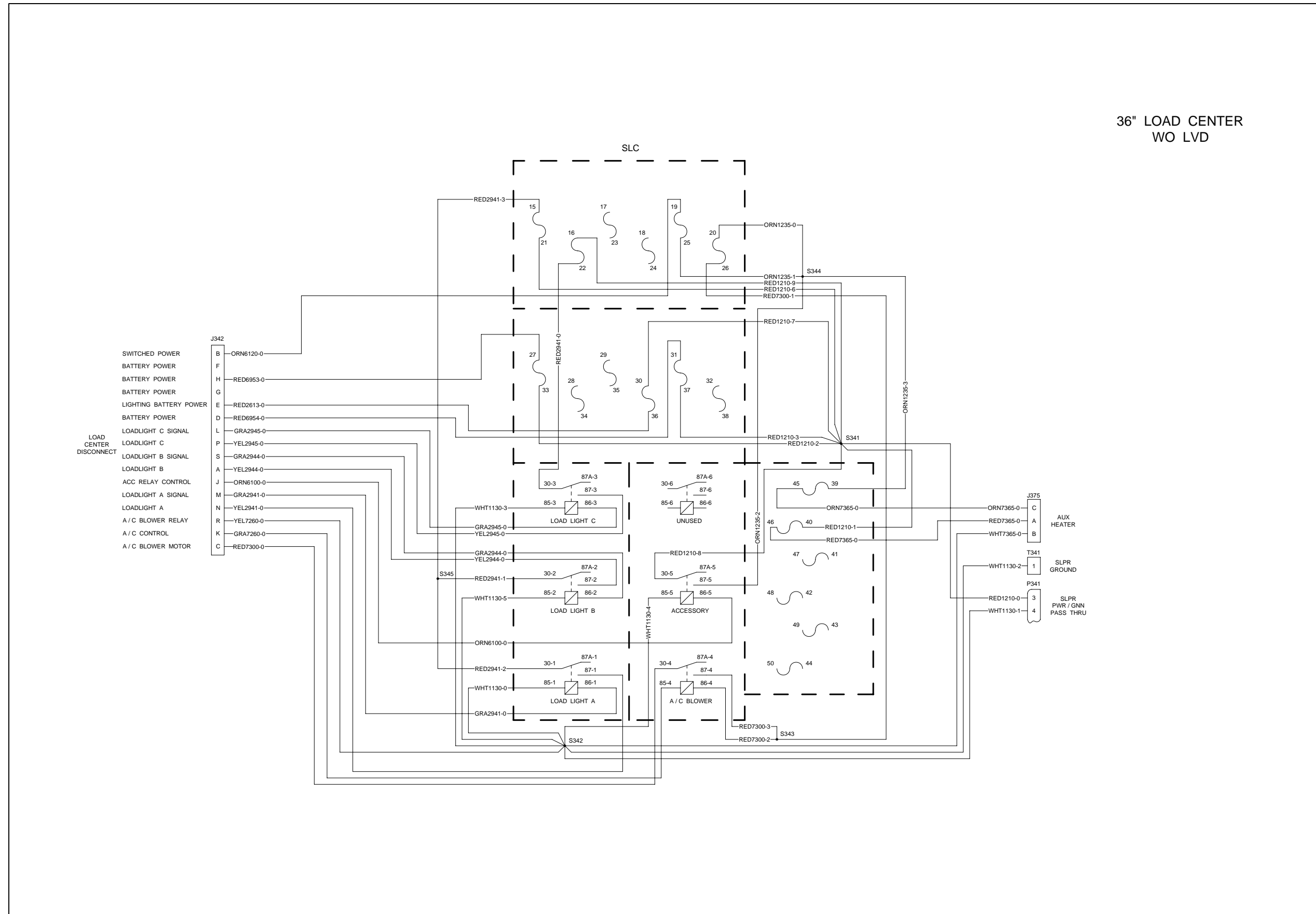

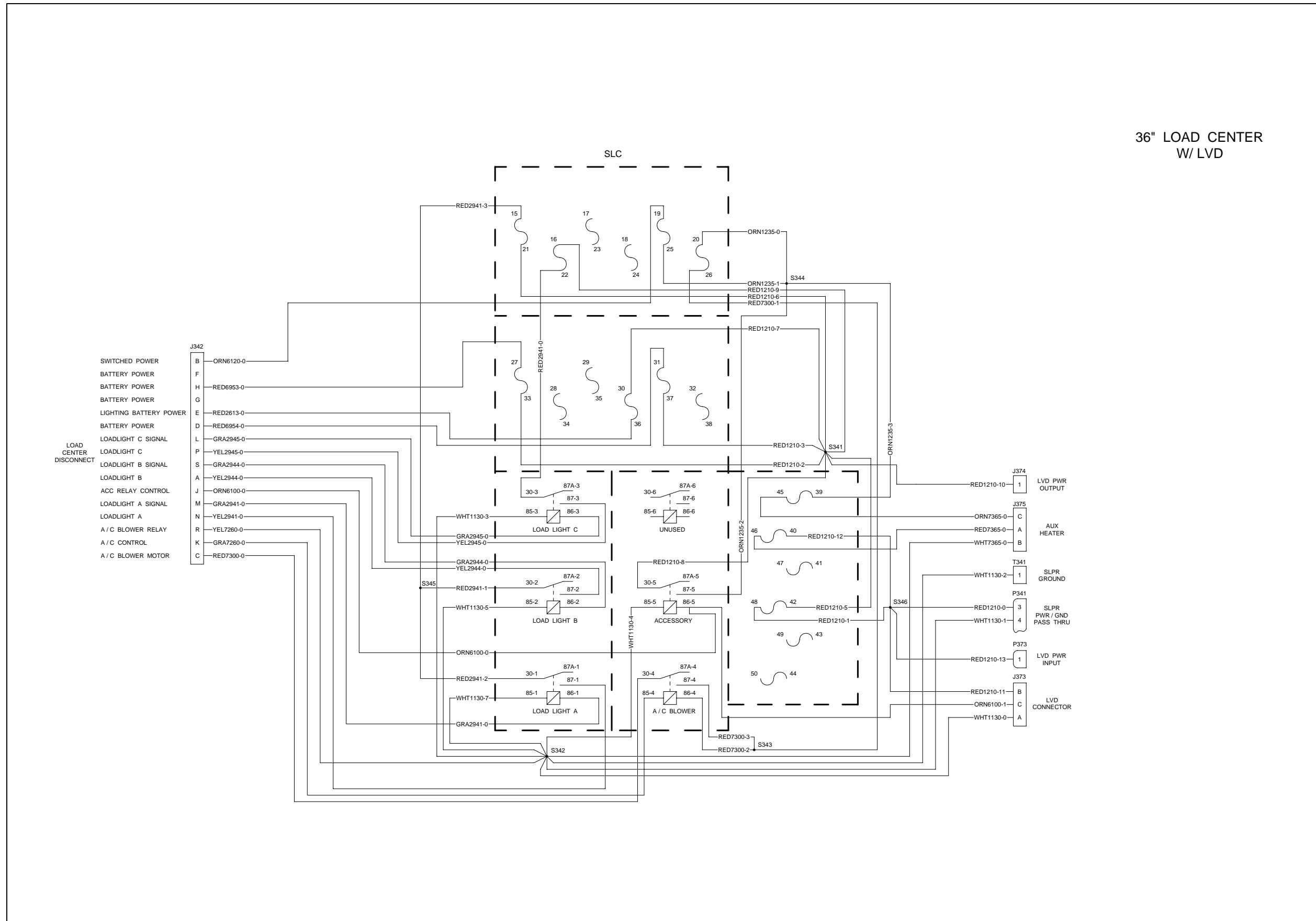

SLEEPER AUDIO - 36"



SLEEPER AUDIO - 48 / 63 / 70"

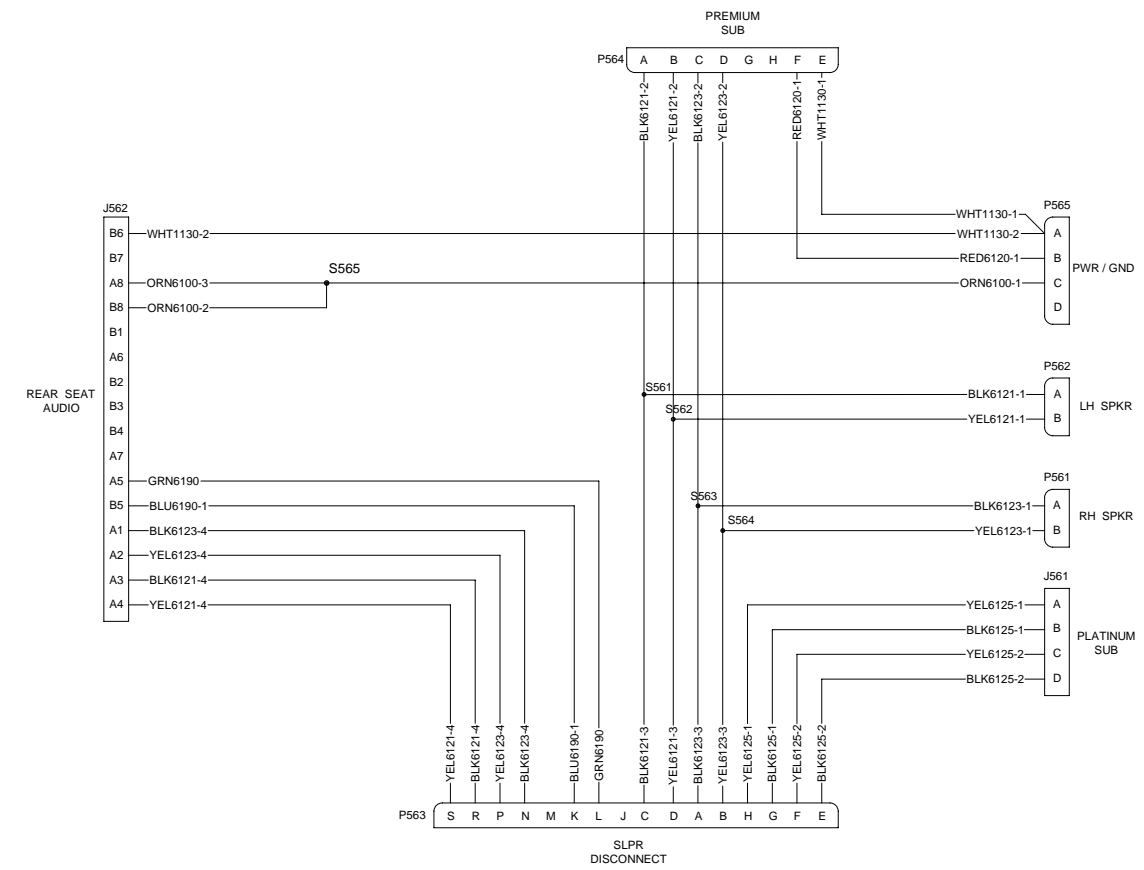

VORAD CAB HARNESS

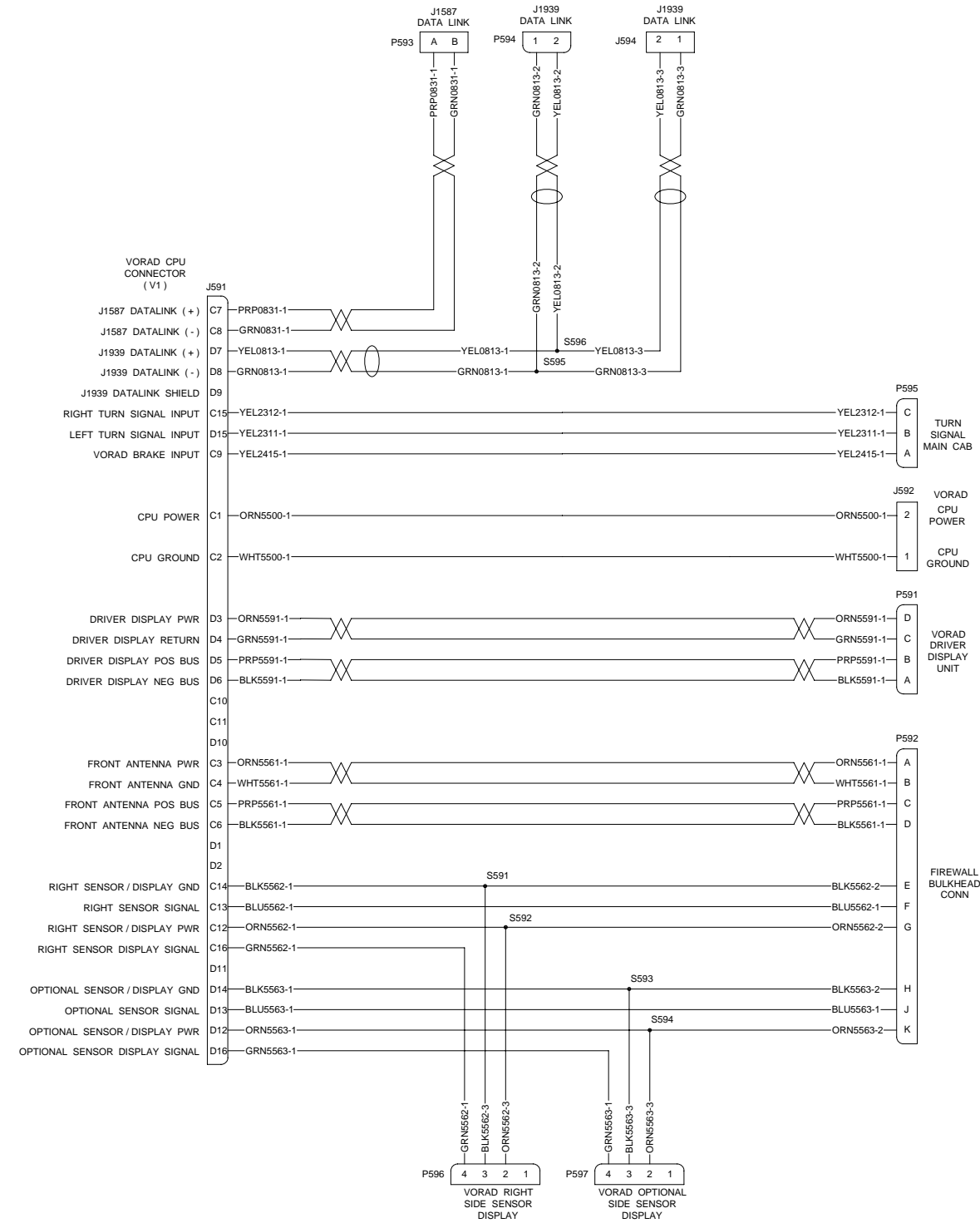

VORAD CHASSIS HARNESS

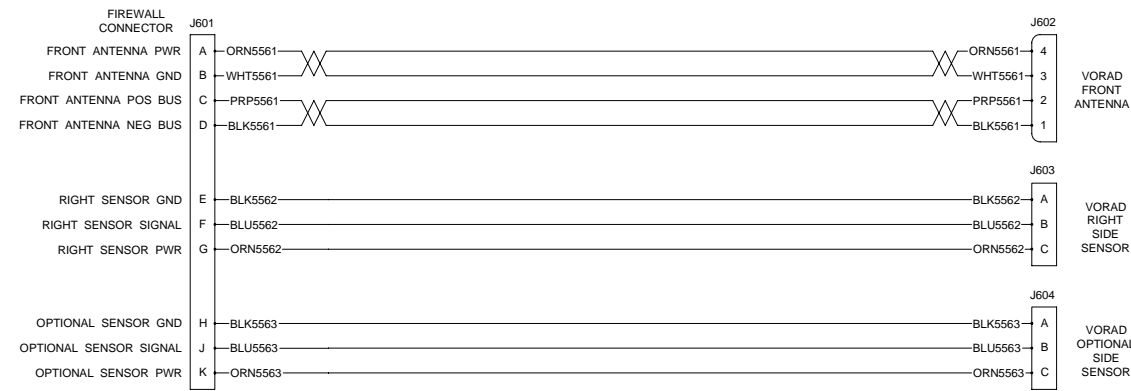

TRAILER HARNESS

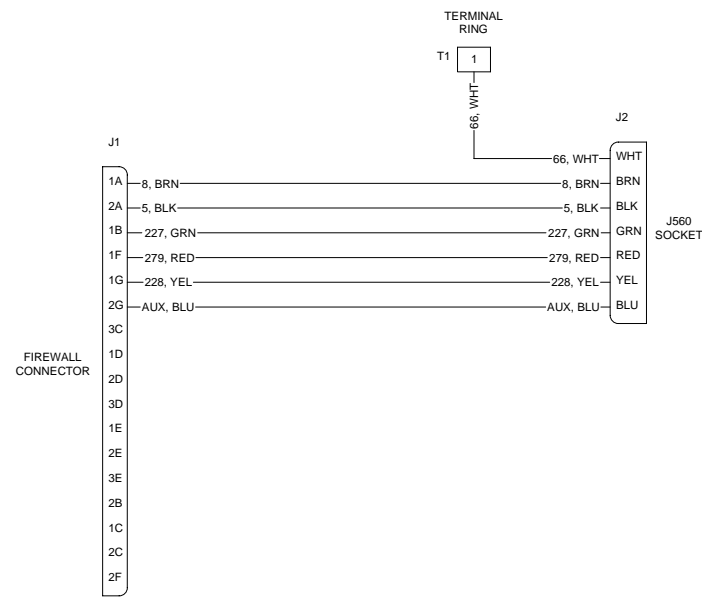

CHASSIS HARNESS

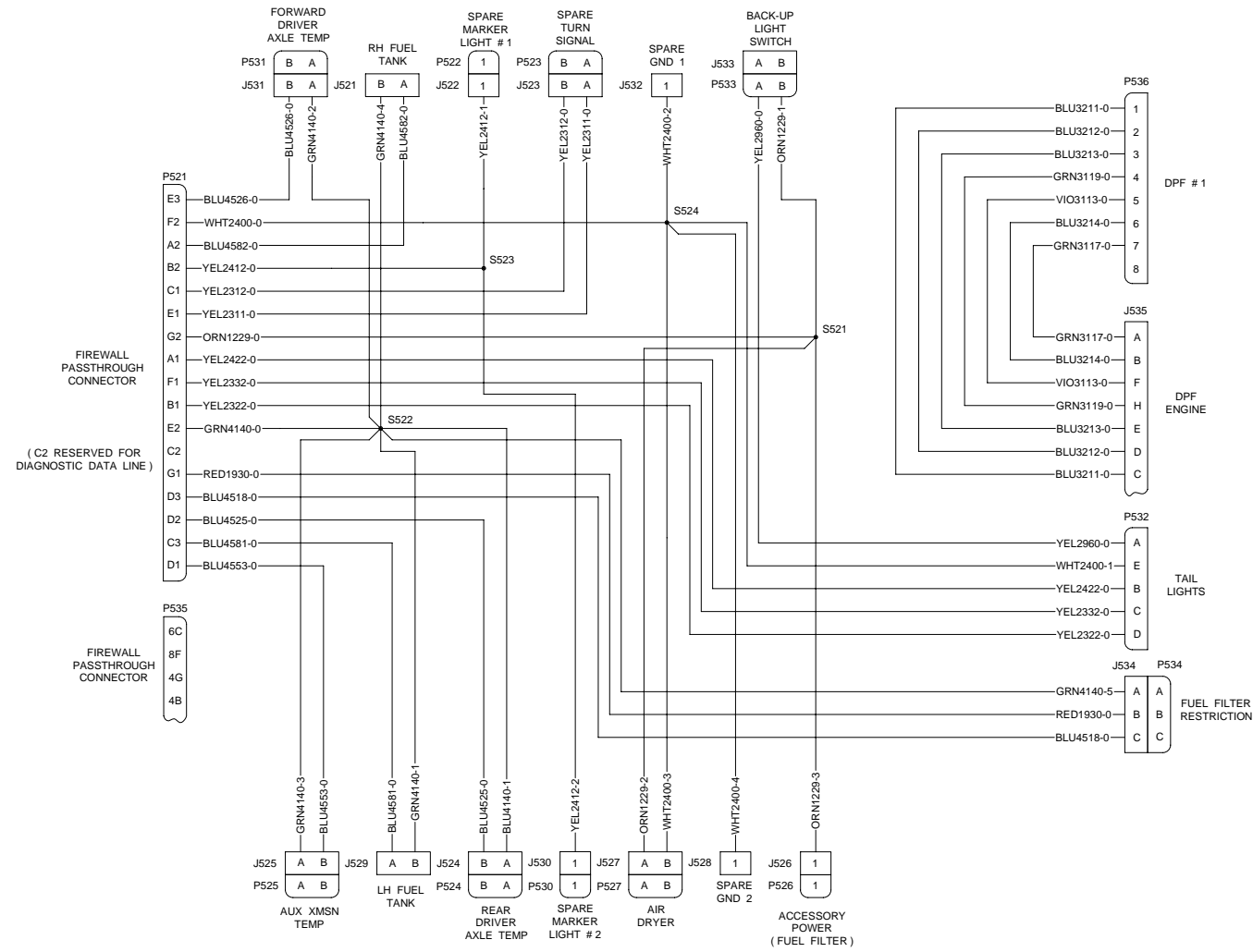

FIREWALL HARNESS

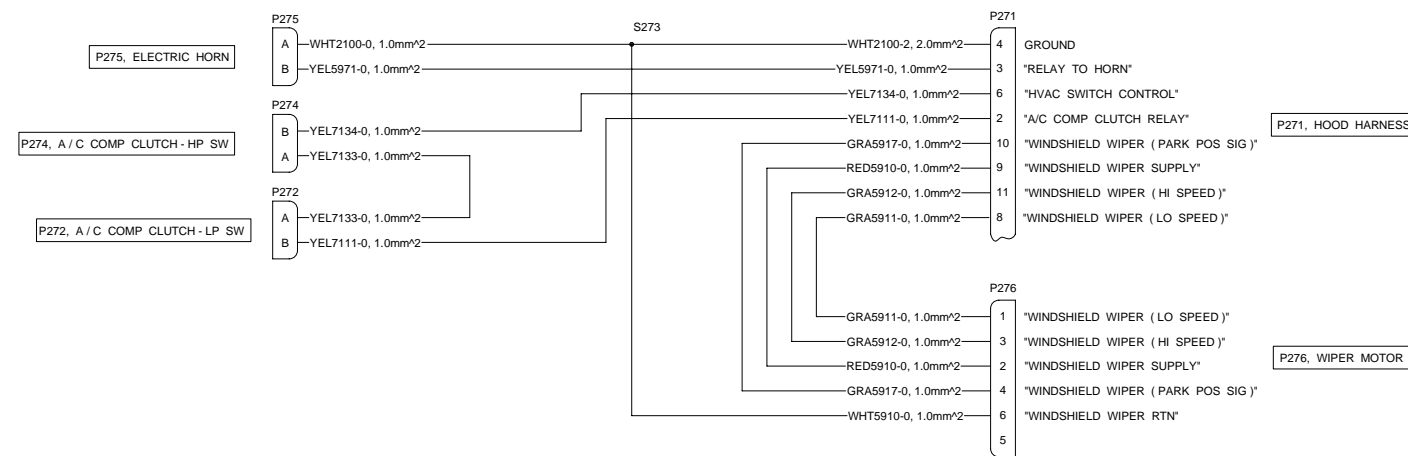

HOOD HARNESS  
( MODEL 384, 386, 388, 389 )

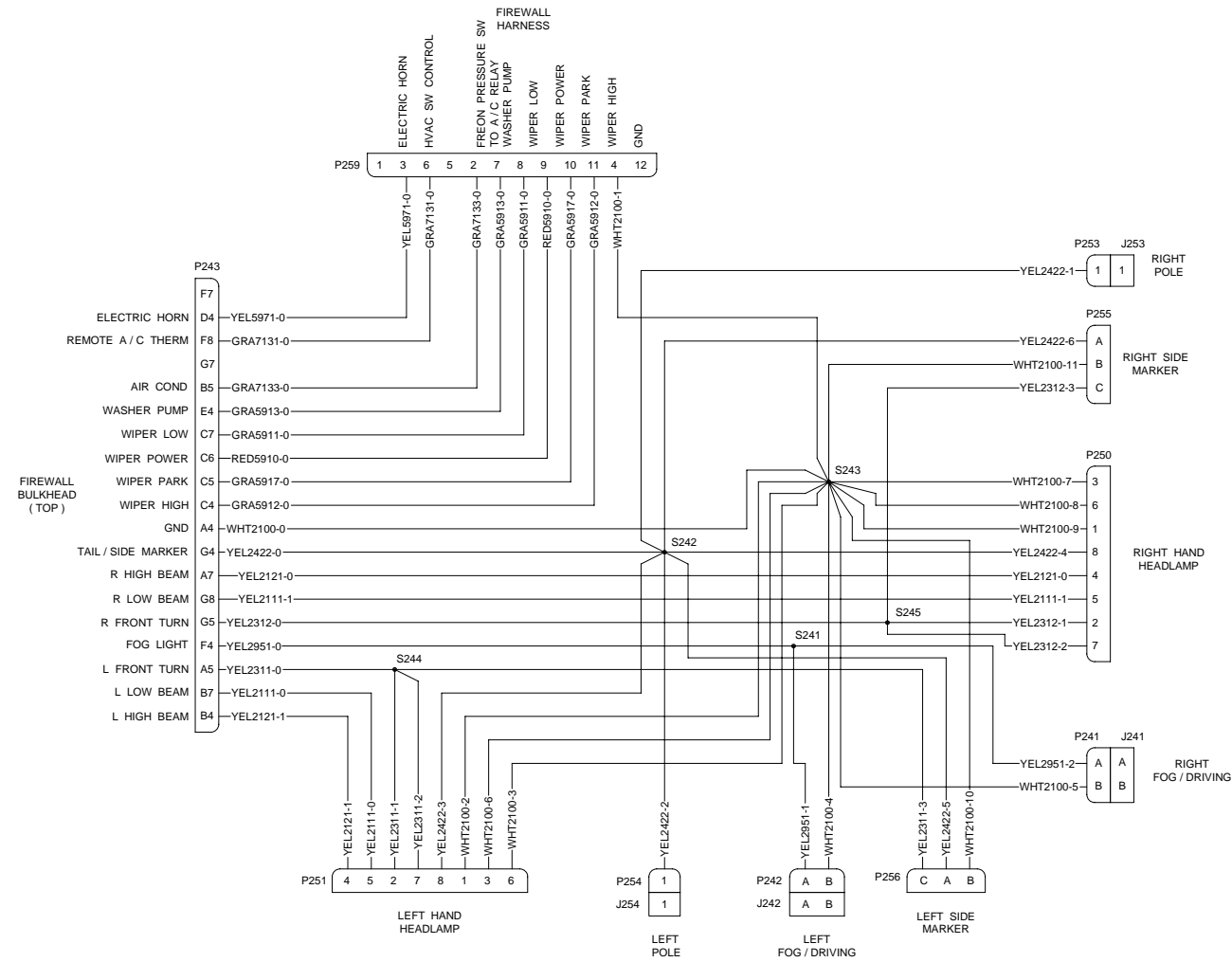

HOOD HARNESS  
(MODEL 365, 367)

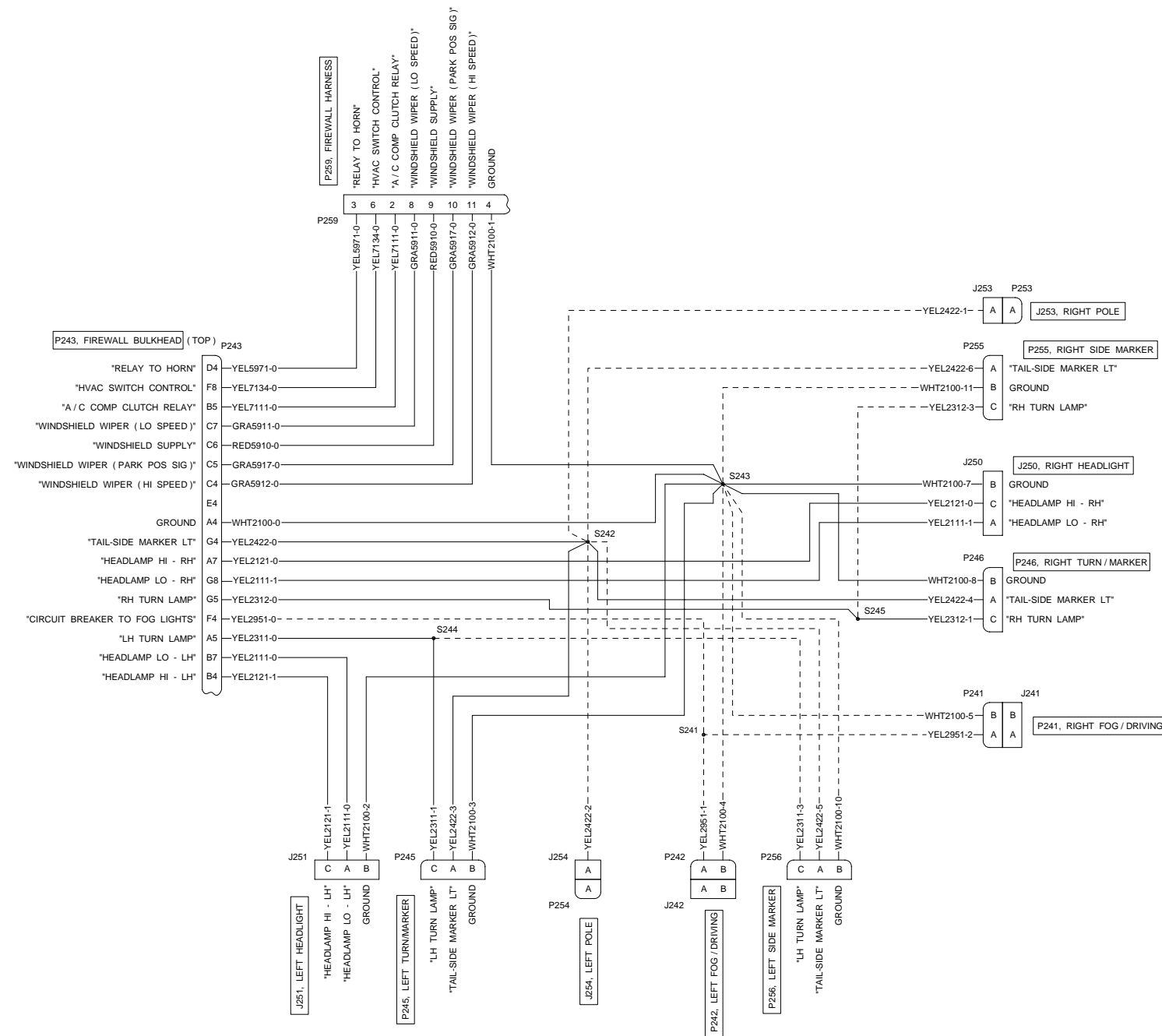

ABS CHASSIS

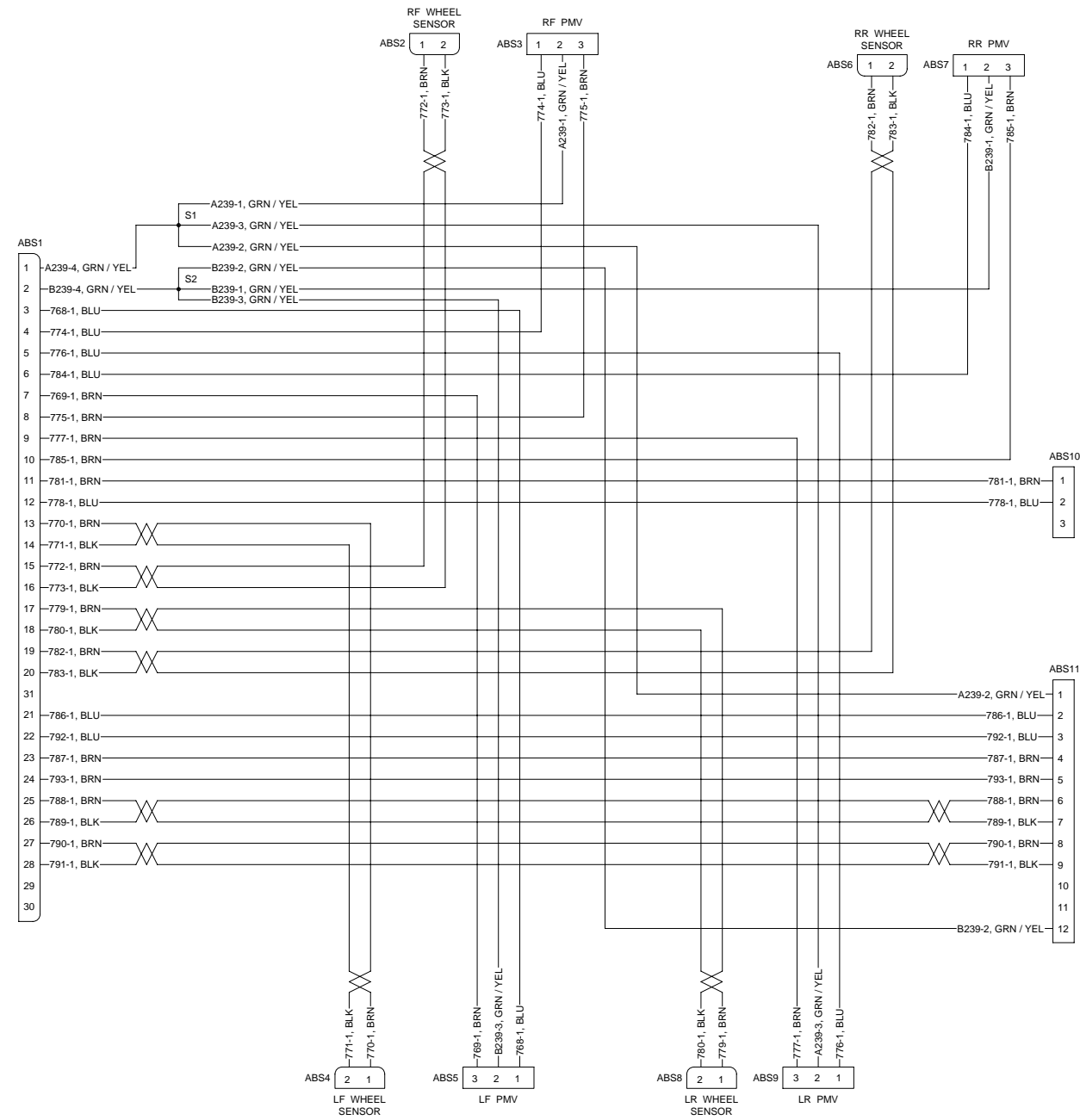

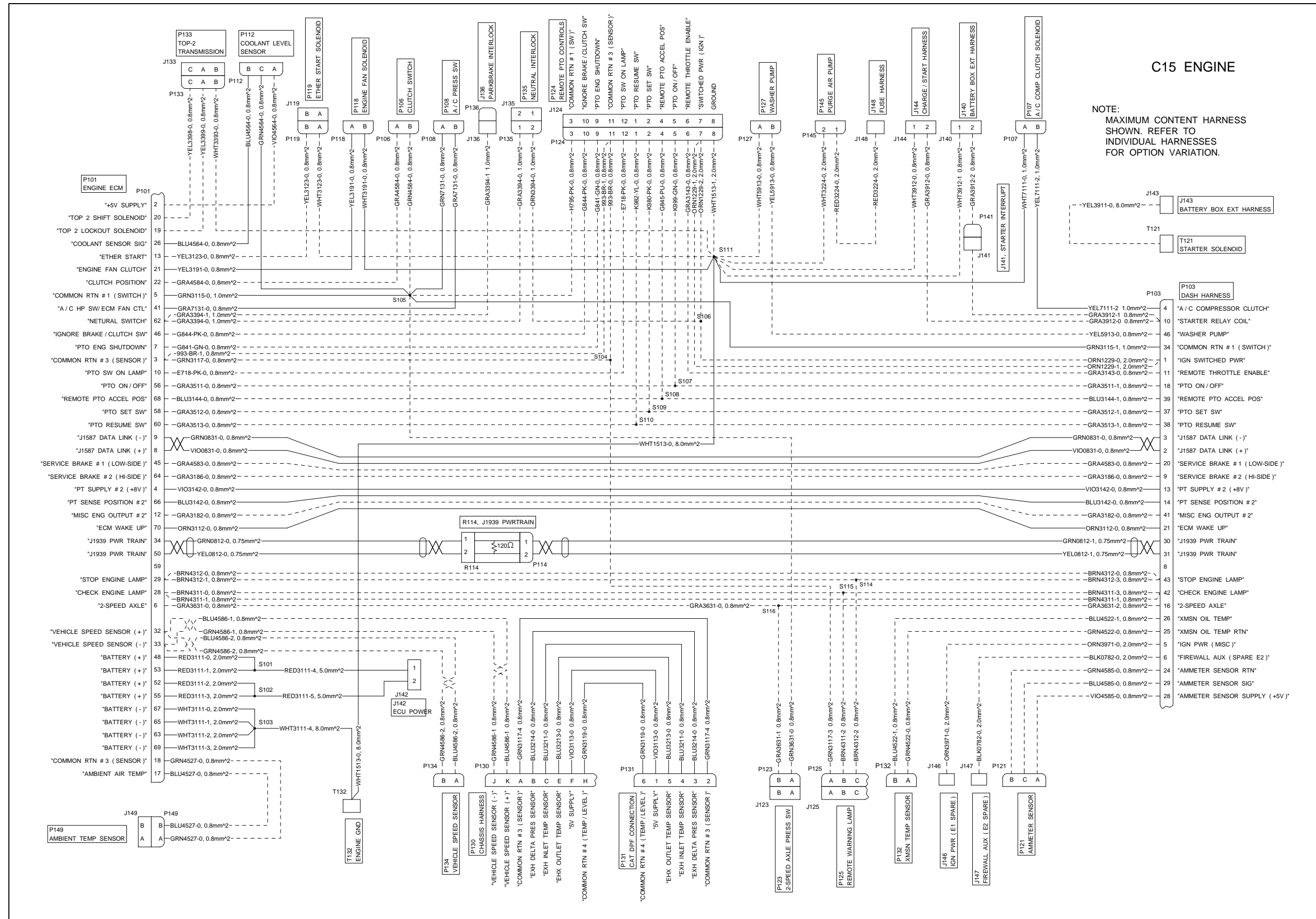

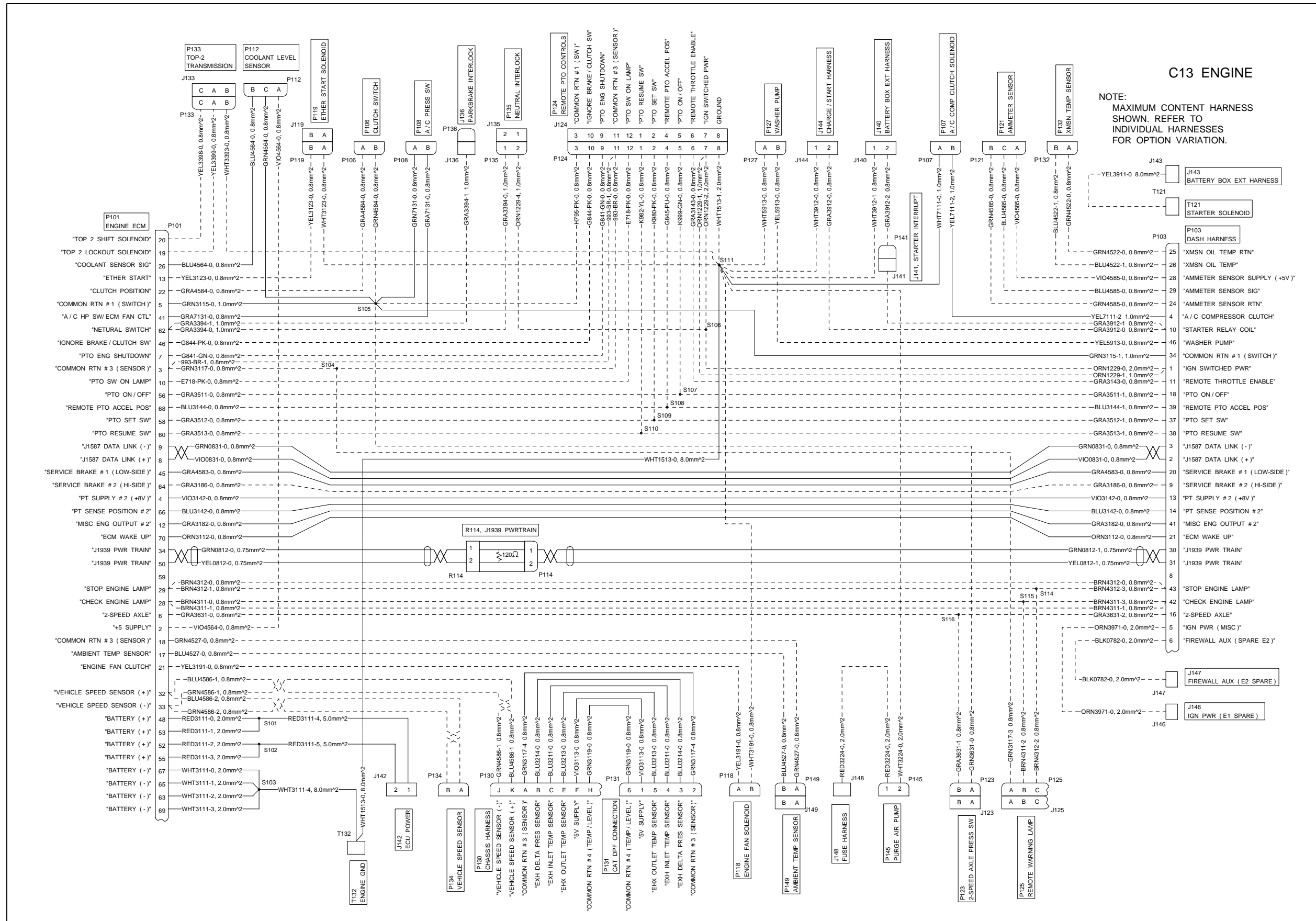

**C13 ENGINE**

NOTE:  
MAXIMUM CONTENT HARNESS  
SHOWN. REFER TO  
INDIVIDUAL HARNESSES  
FOR OPTION VARIATION.



A DIVISION OF **PACCAR**

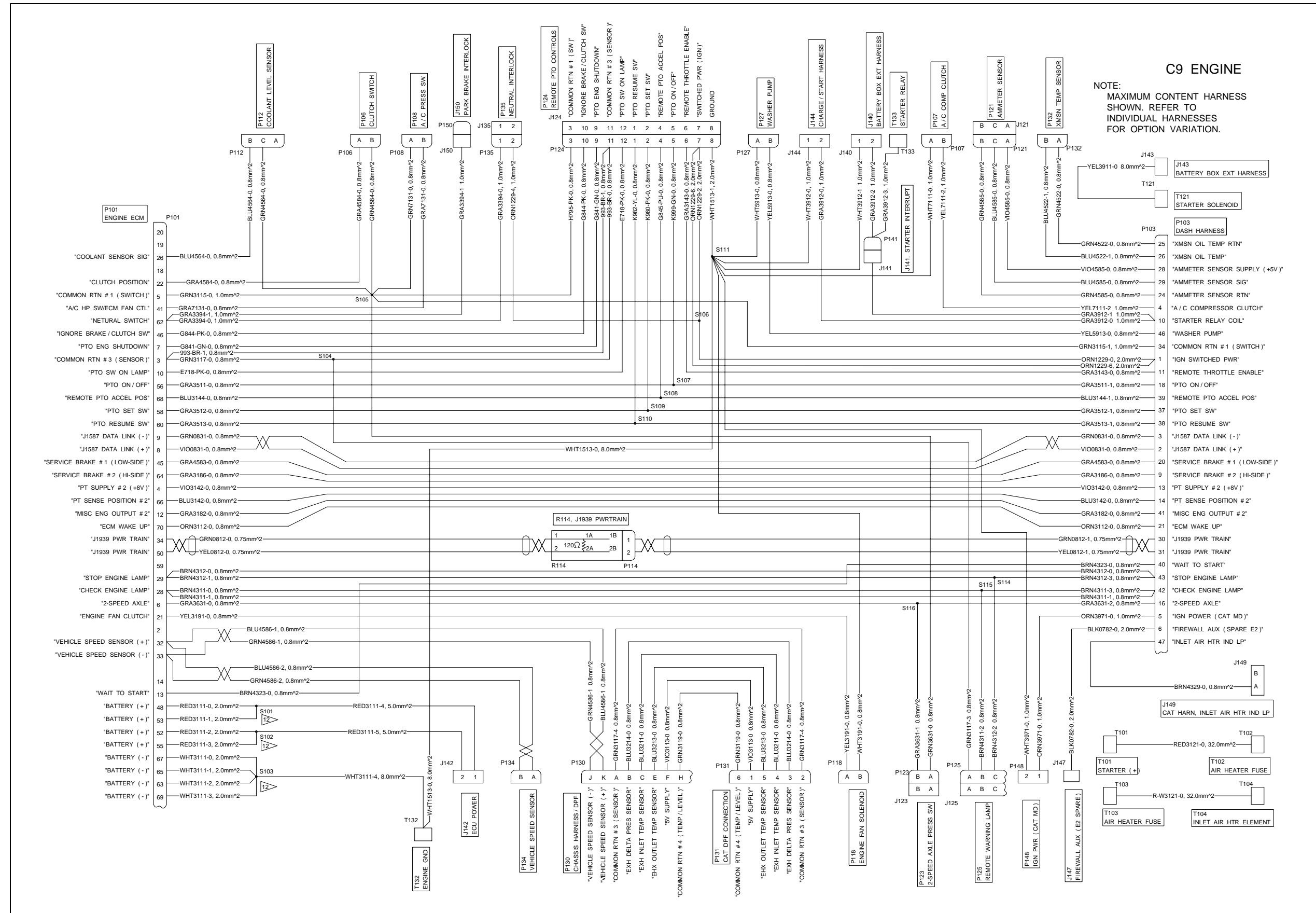

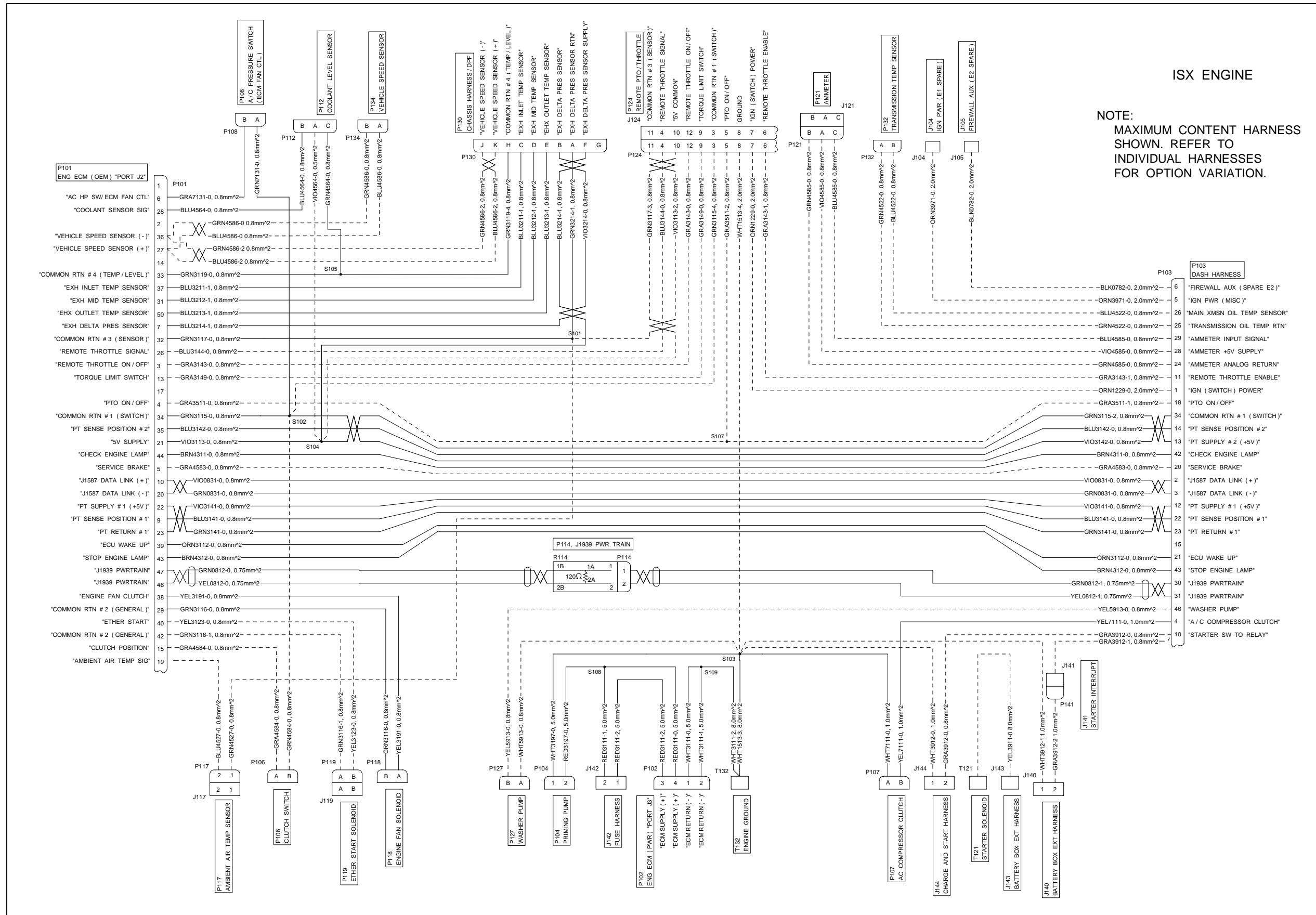



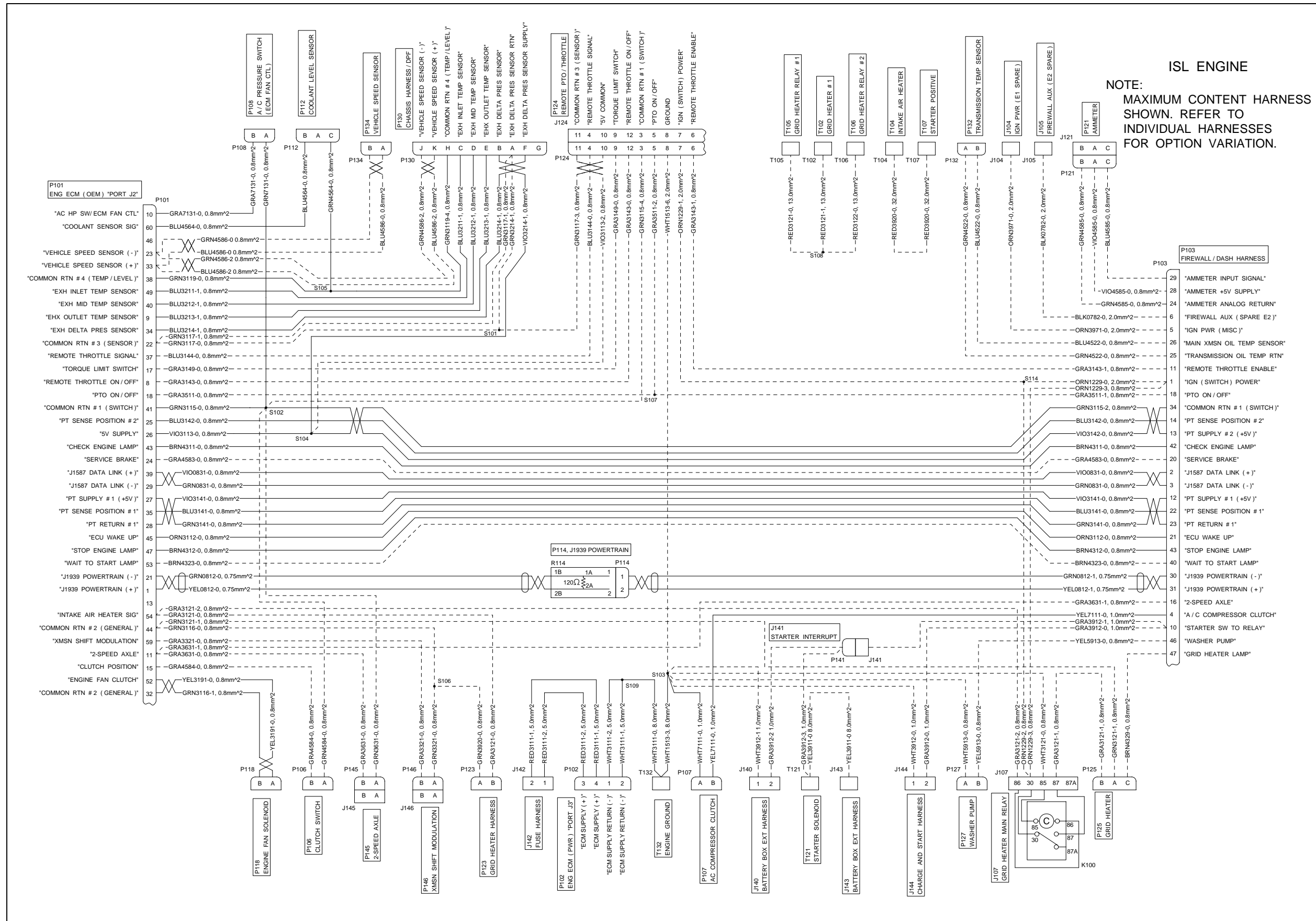

C9 / C13 / C15 CHARGE / START

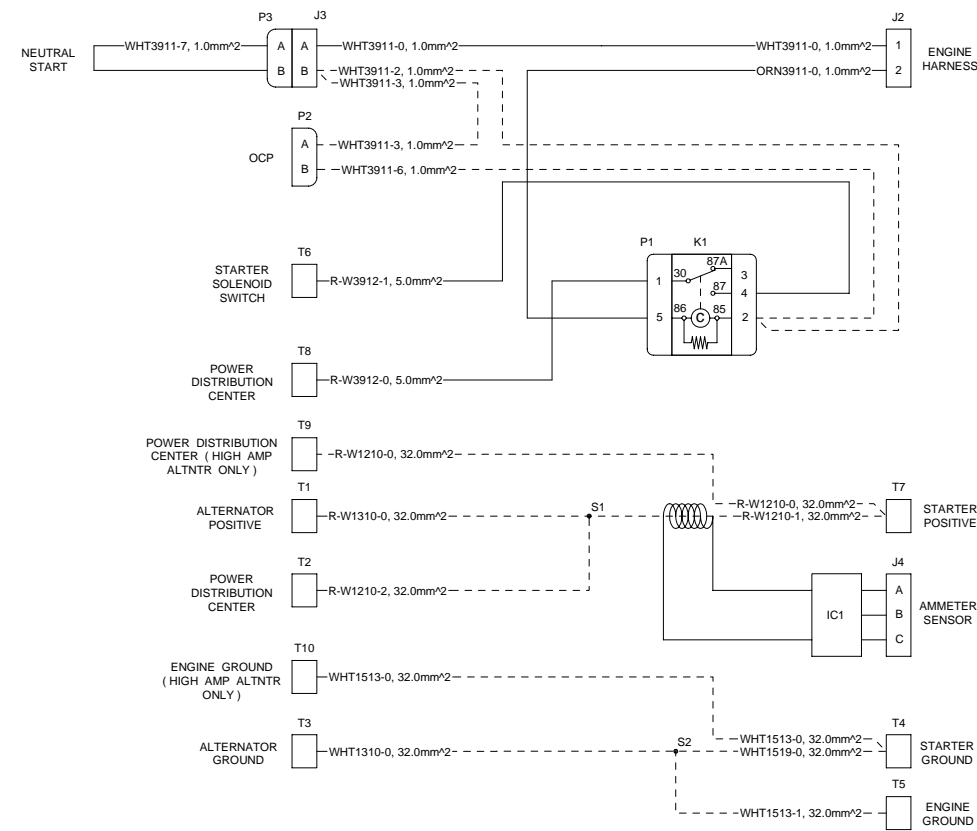

ISX CHARGE / START

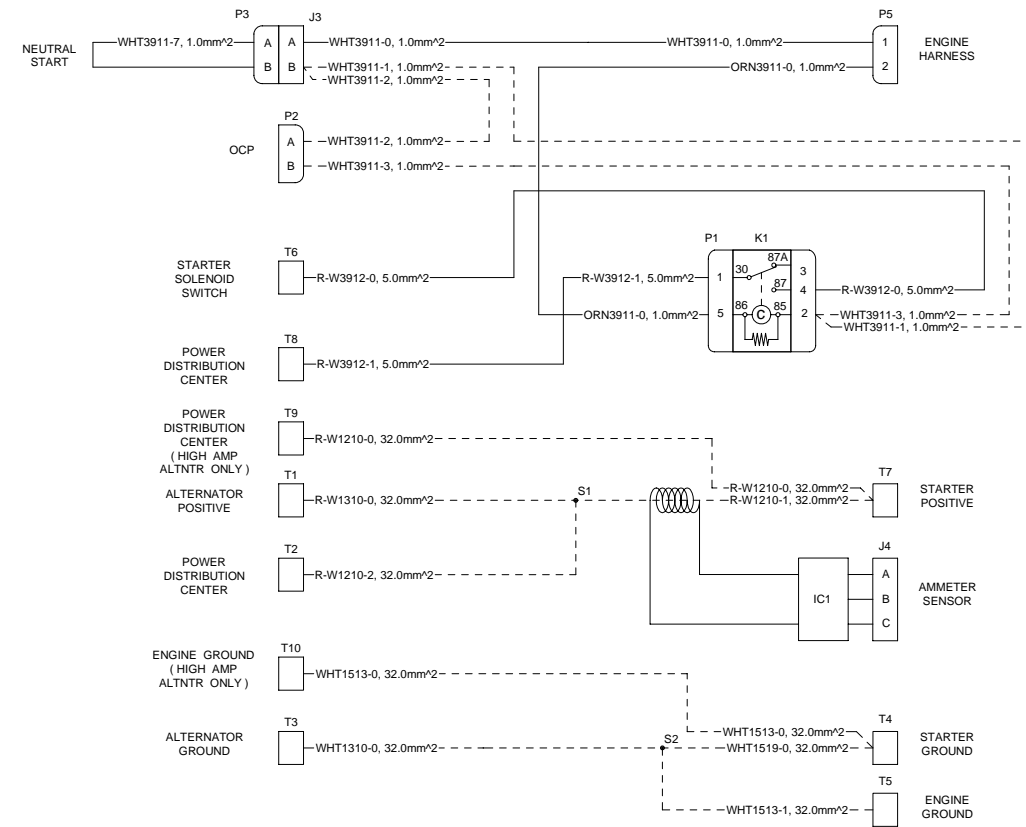

ISM CHARGE / START

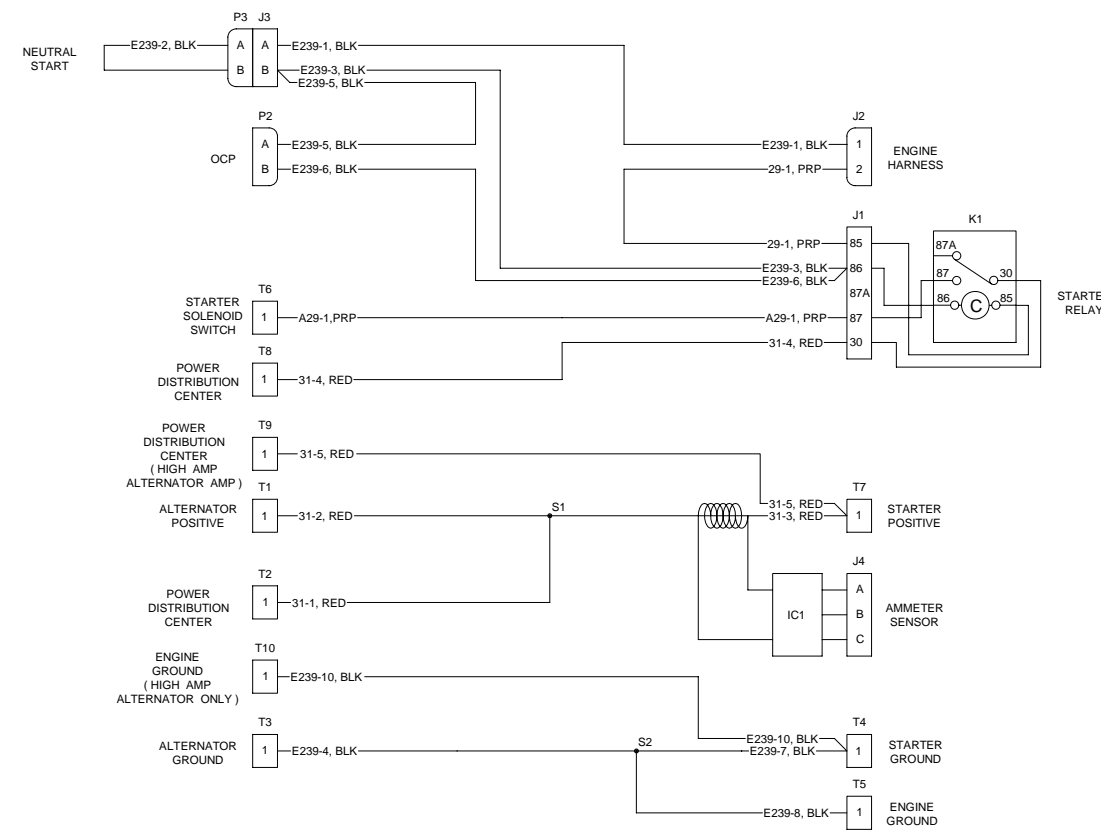

ISC / ISL CHARGE / START

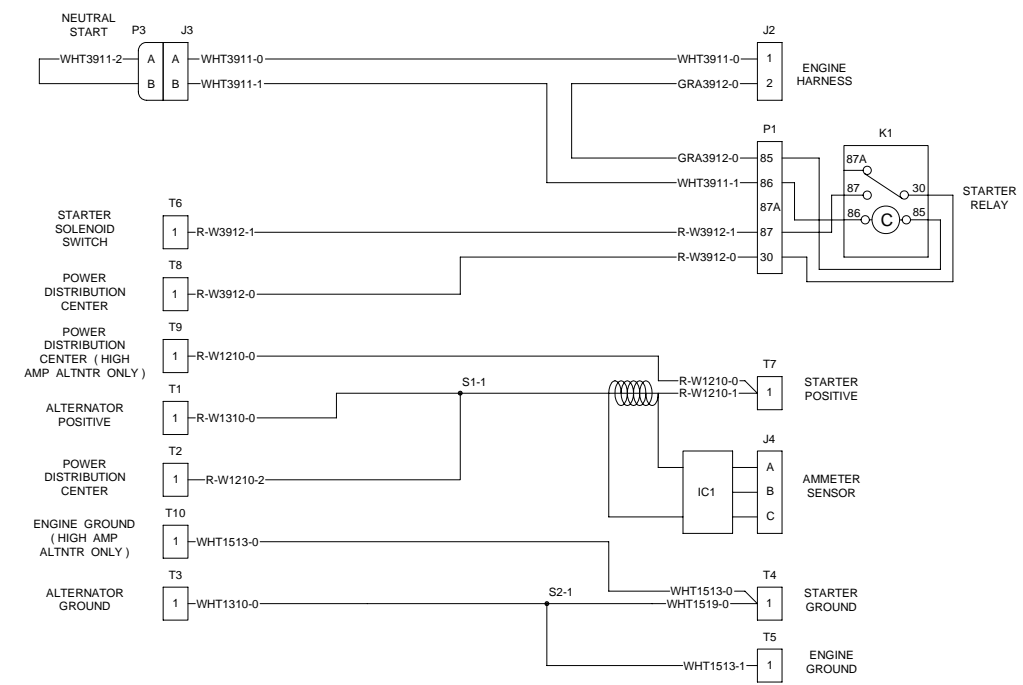

ENGINE BRAKE

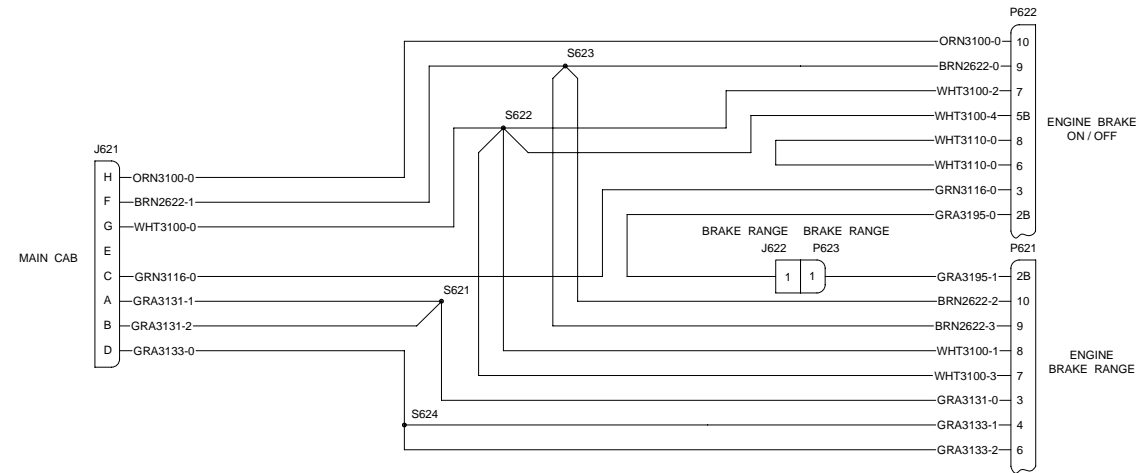

CAT FUSE HARNESS

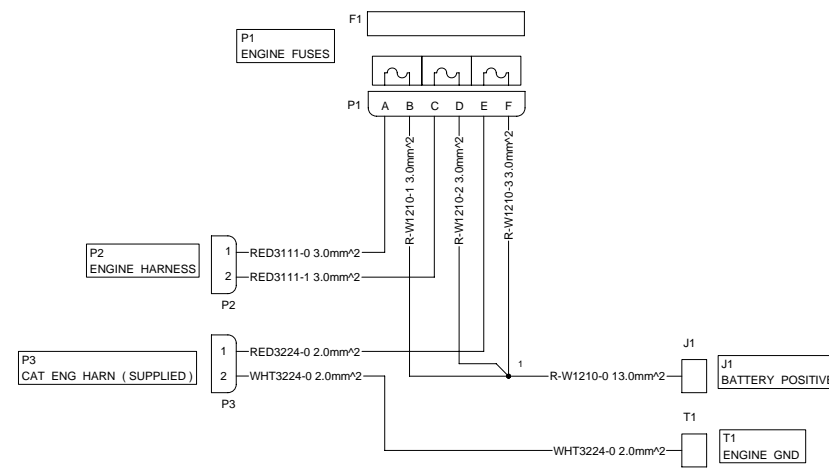

CUMMINS FUSE HARNESS

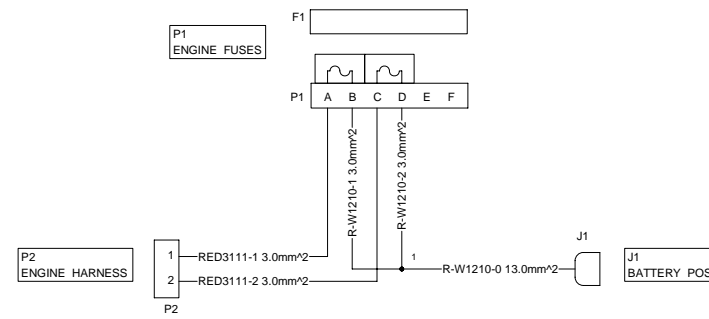

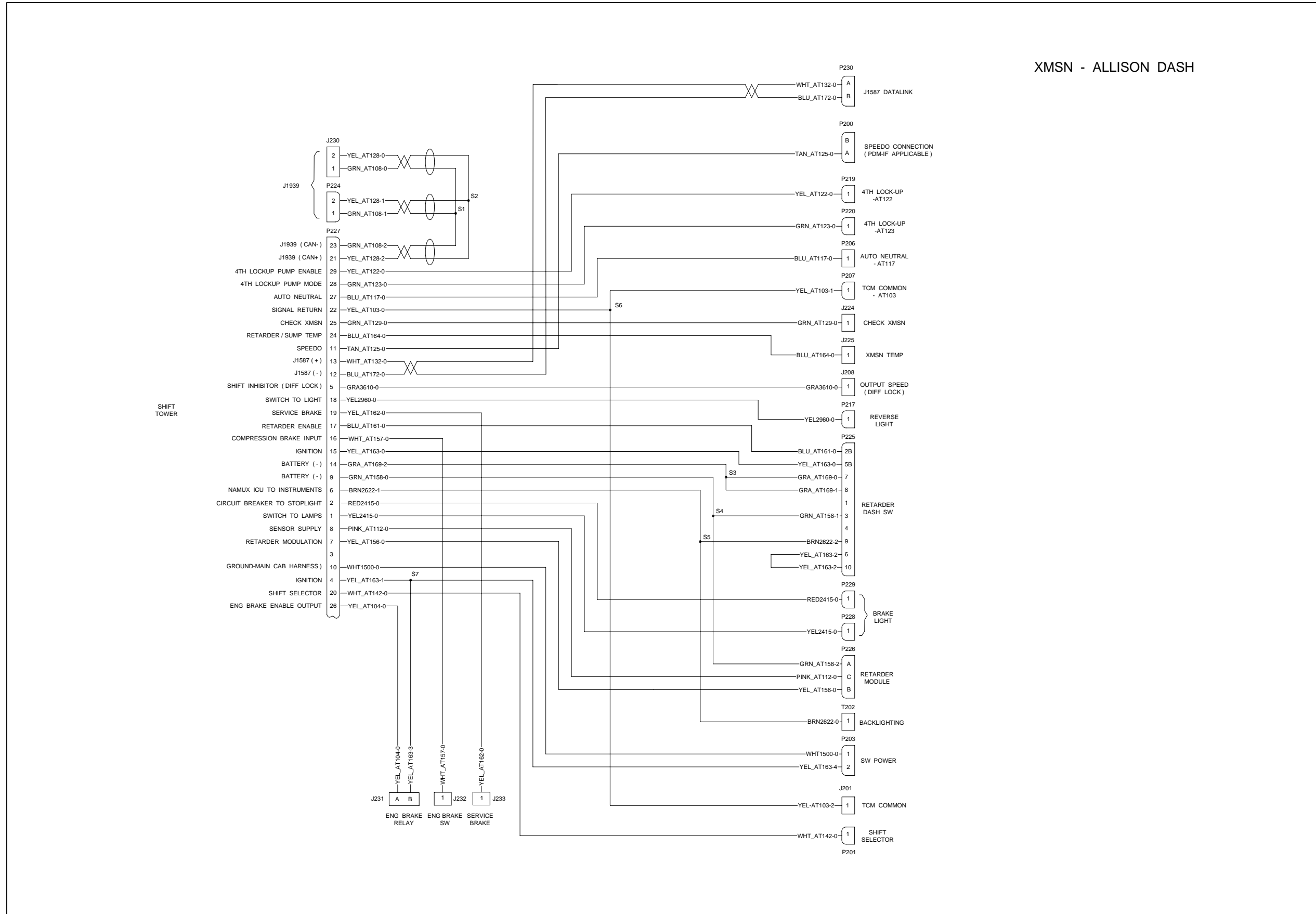

XMSN - ALLISON DASH

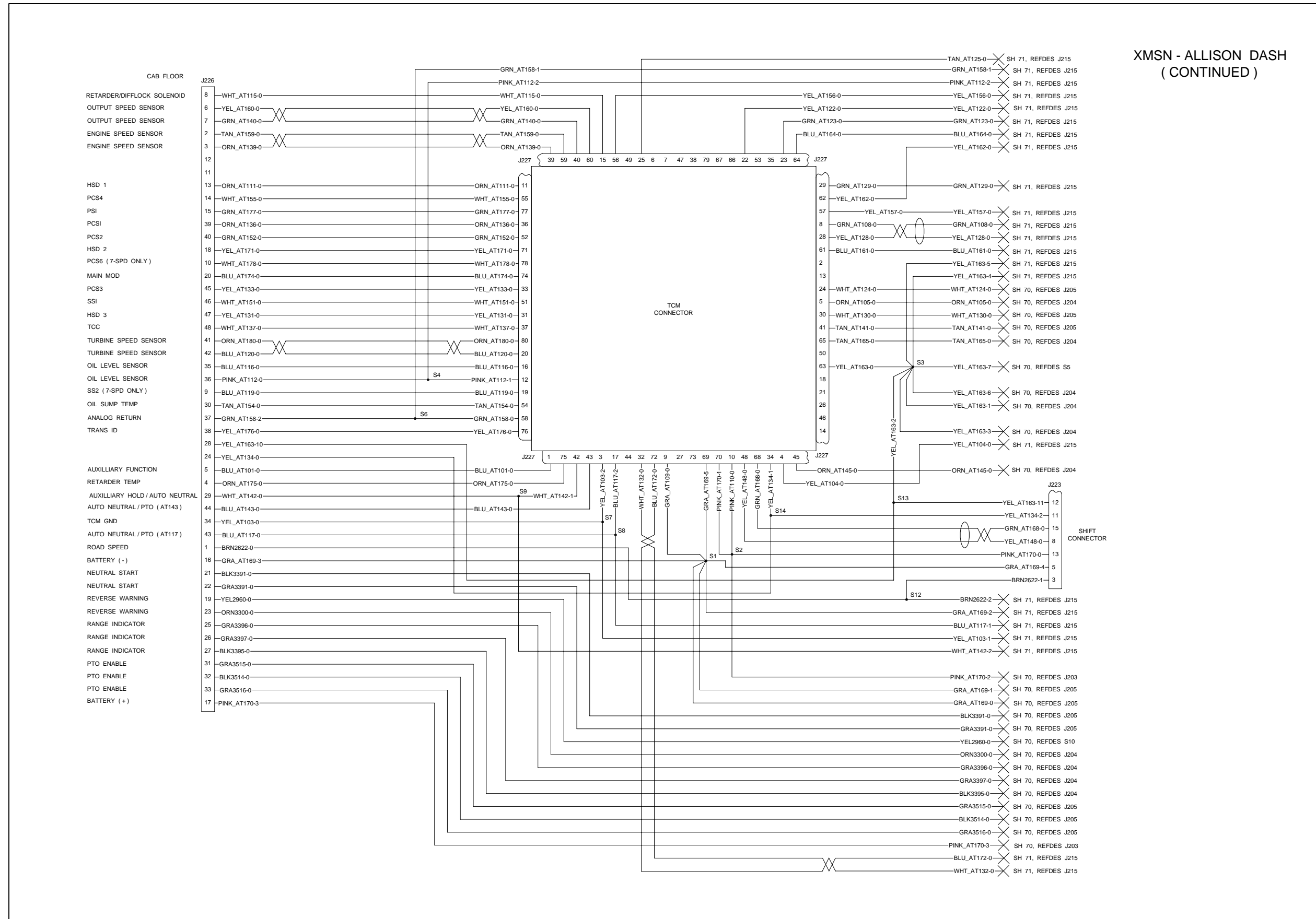

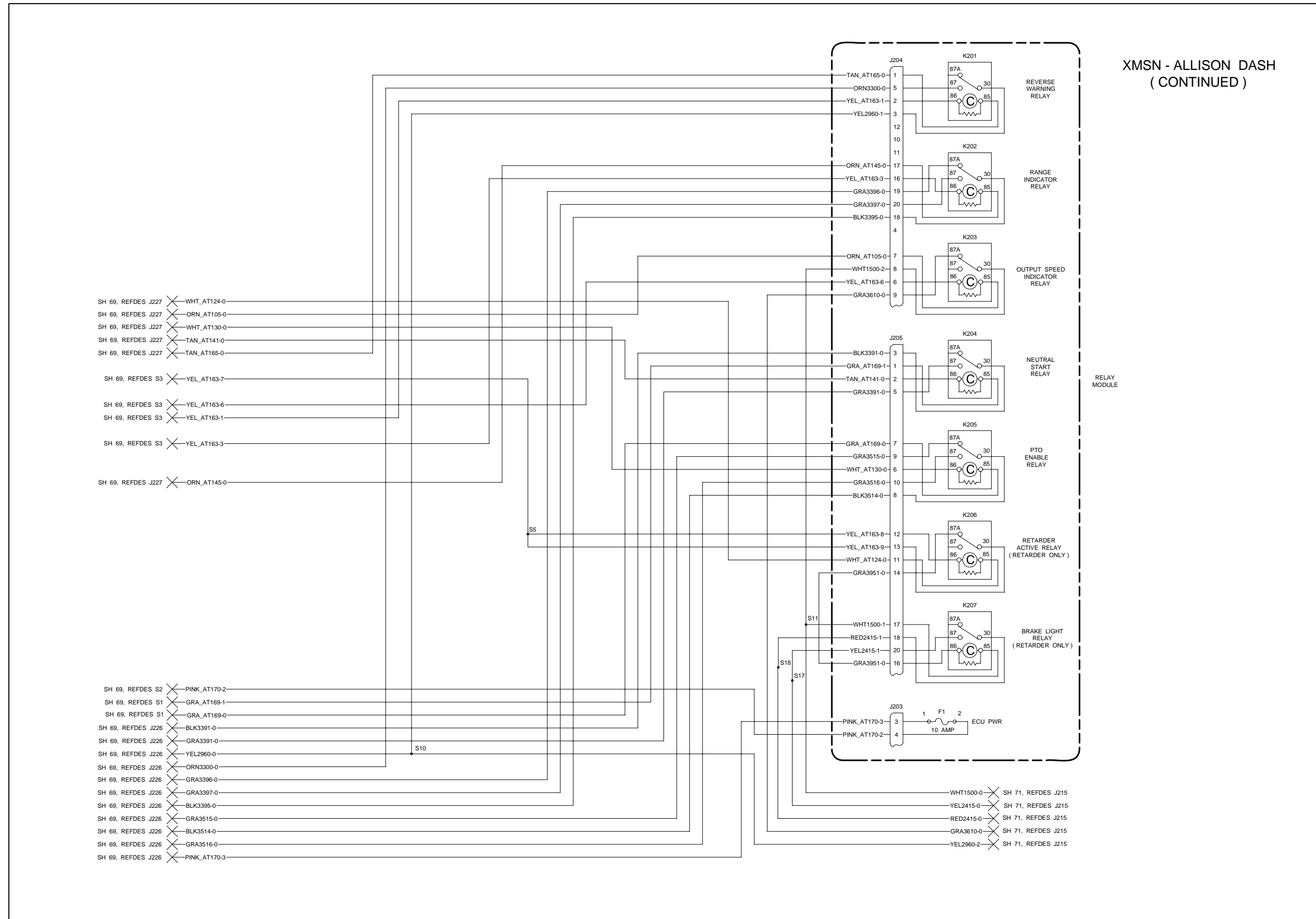

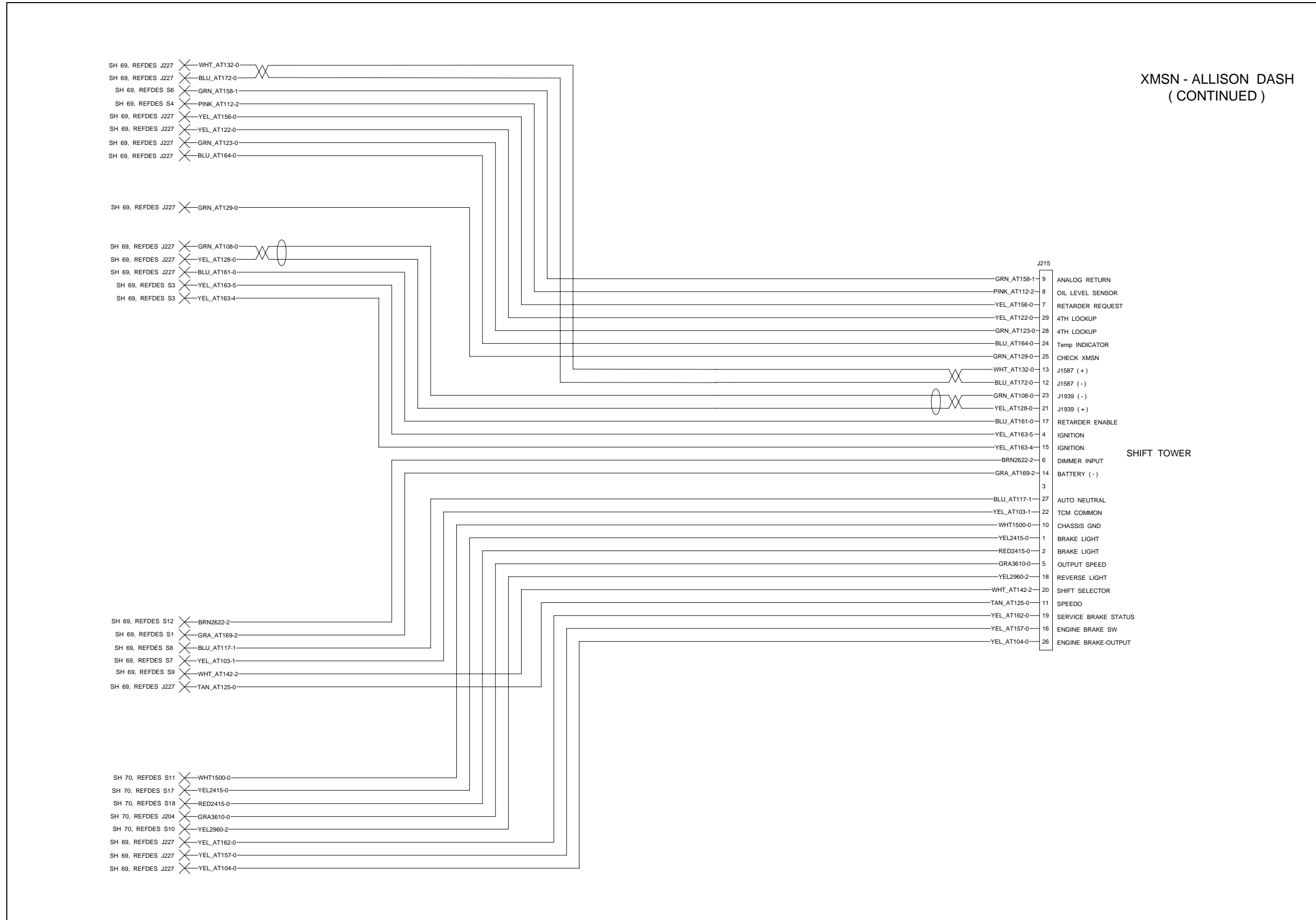

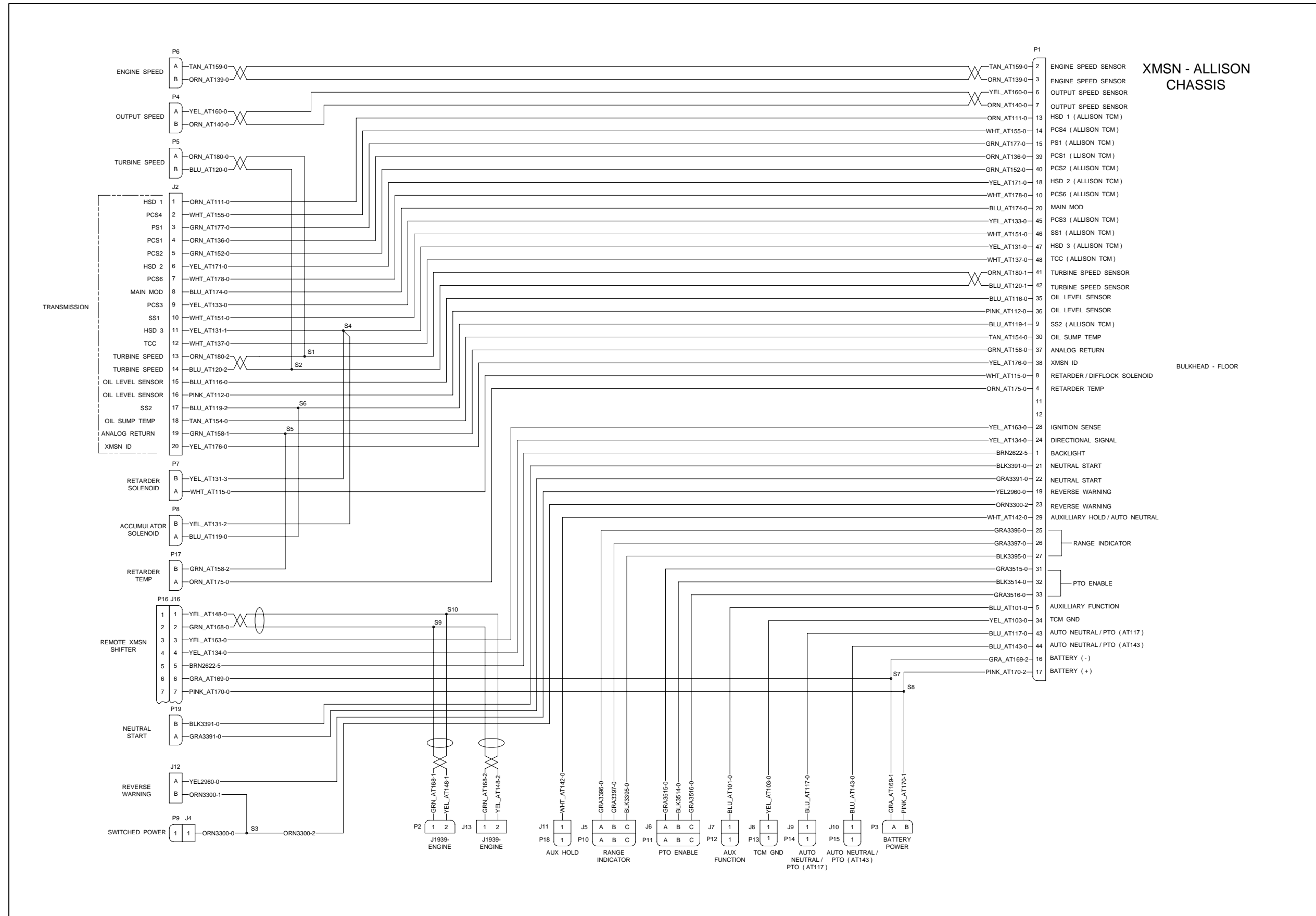

AUTOSHIFT DASH

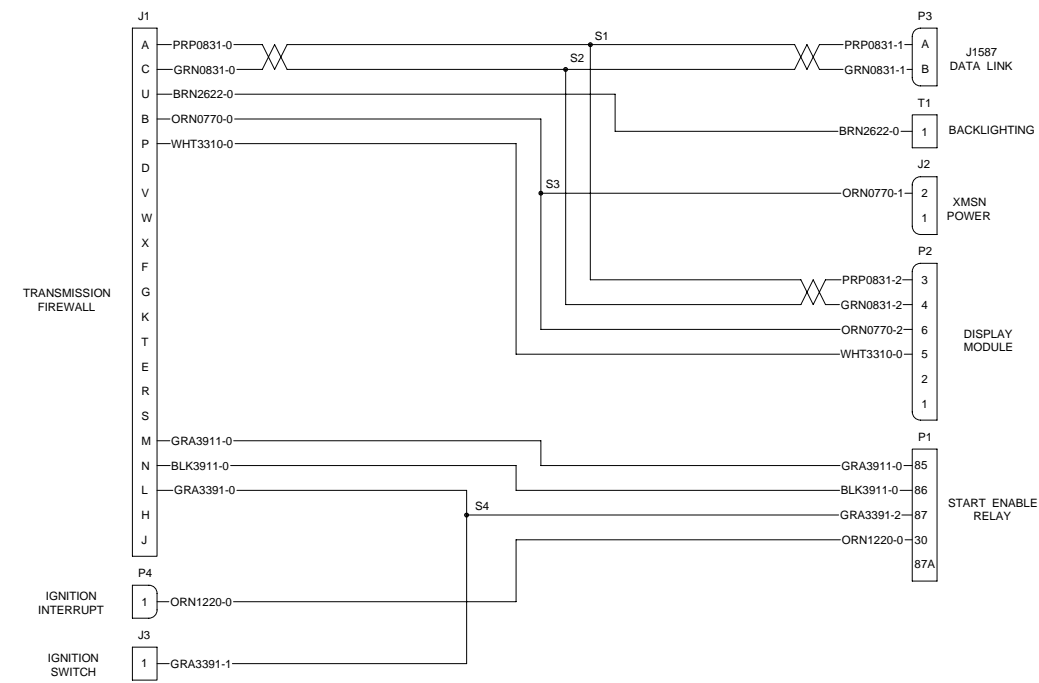

AUTO / ULTRA XMSN

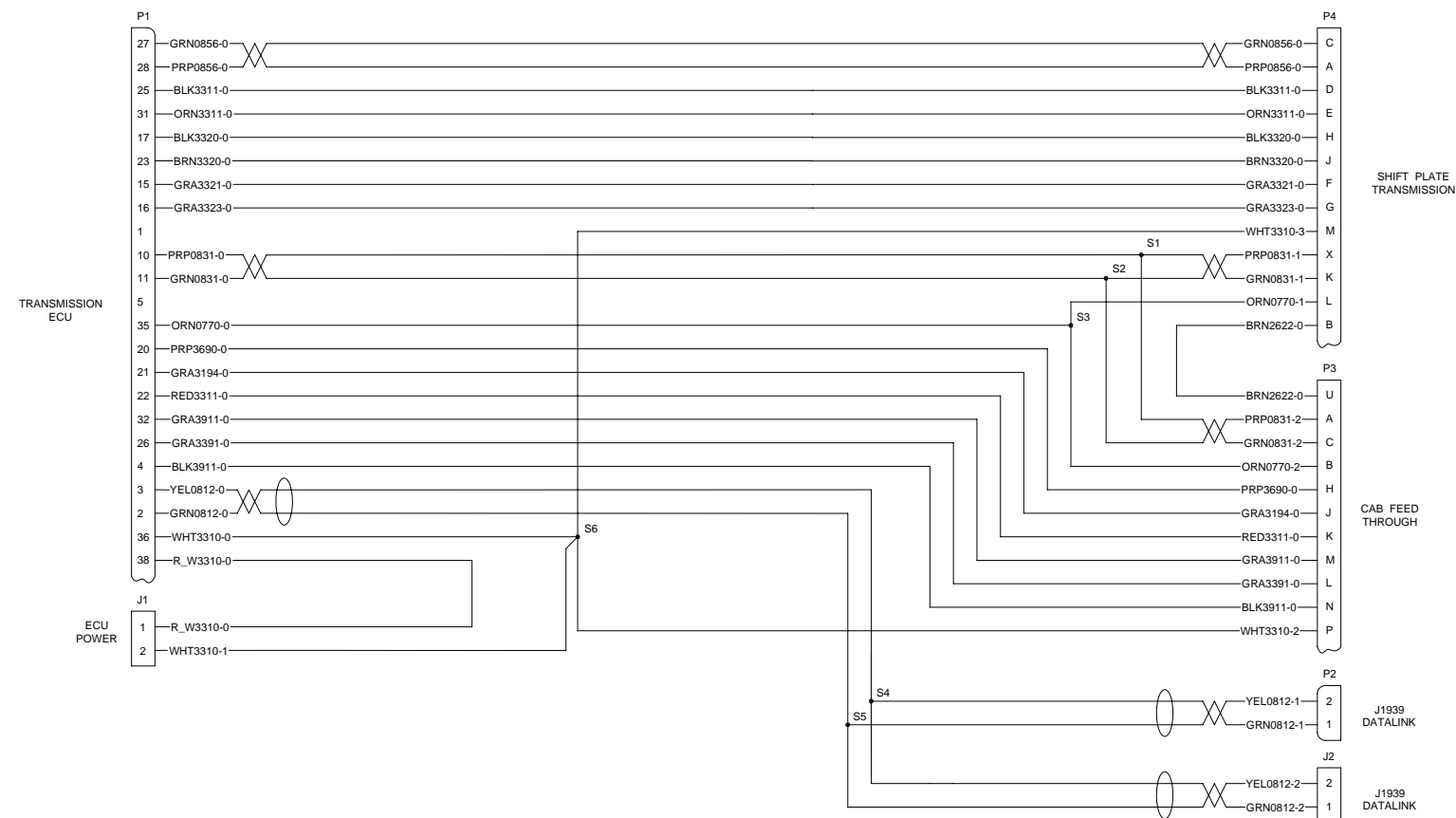

ULTRASHIFT DASH

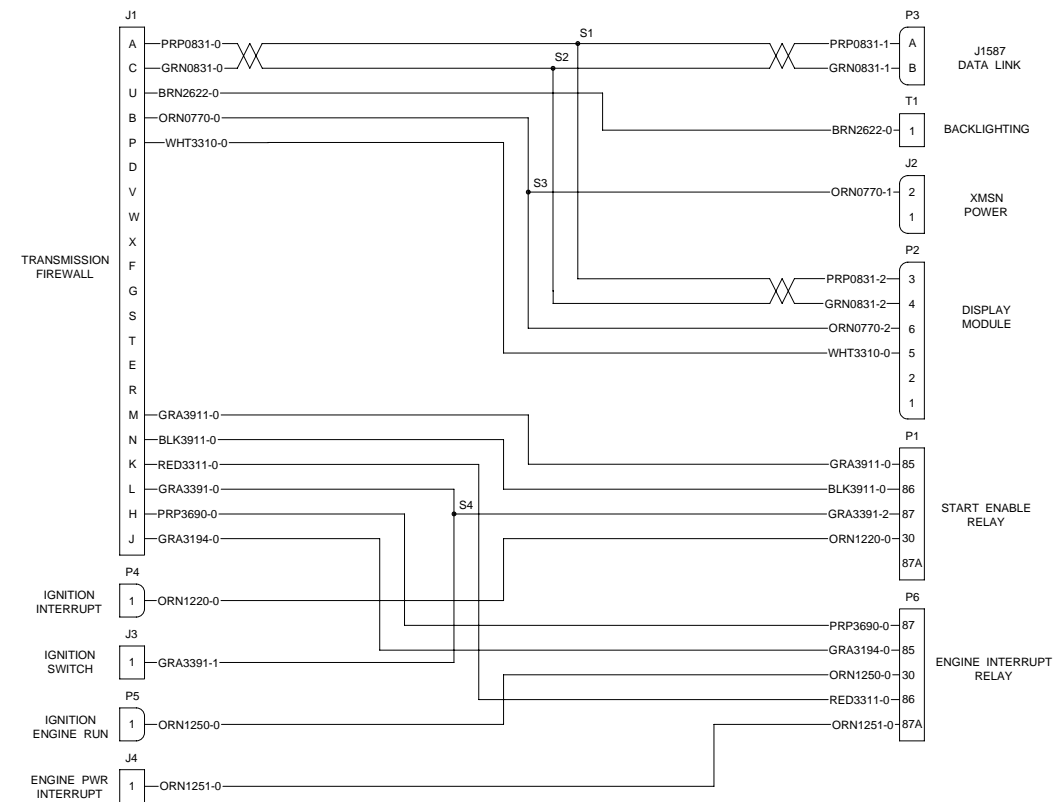

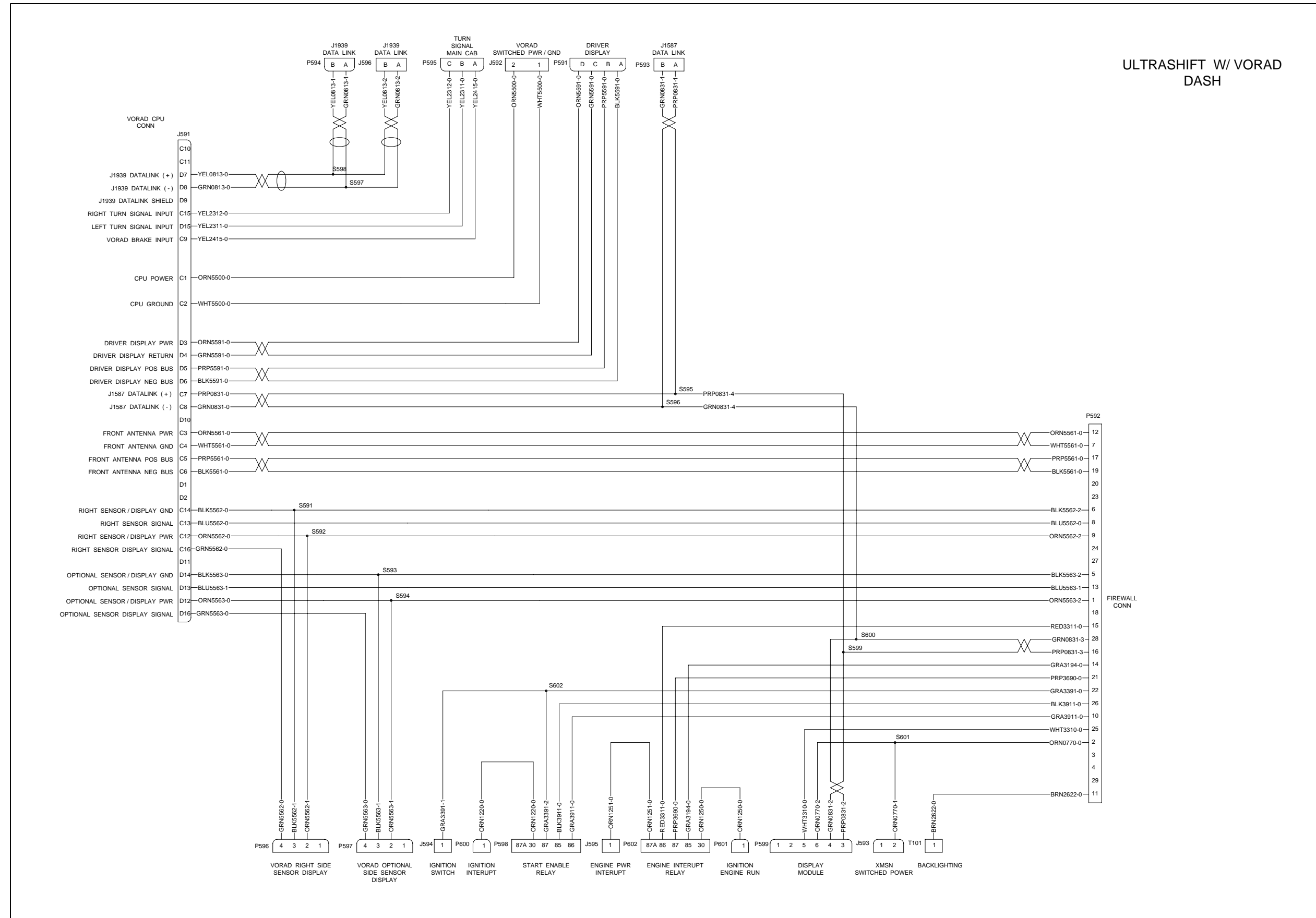

ULTRASHIFT W/ VORAD  
XMSN

