

1 9 04-15



Service Information Bulletin

SUBJECT	DATE
SPN 651 (MCM) (EPA10); SPN 652 (MCM) (EPA10); SPN 653 (MCM) (EPA10); SPN 654 (MCM) (EPA10); SPN 655 (MCM) (EPA10); SPN 656 (MCM) (EPA10)	September 2015

Additions, Revisions, or Updates

Publication Number / Title	Platform	Section Title	Change
DDC-SVC-MAN-0084 DDC-SVC-MAN-S084	DD Platform/ EPA10	SPN 651/FMI 3 - EPA10	Revised step 11 and step 15 on how to recognize if MCM already has campaigned MCM. Added a new Picture of the MCM.
		SPN 652/FMI 3 - EPA10	
		SPN 653/FMI 3 - EPA10	
		SPN 654/FMI 3 - EPA10	
		SPN 655/FMI 3 - EPA10	
		SPN 656/FMI 3 - EPA10	



13400 Outer Drive, West, Detroit, Michigan 48239-4001
 Telephone: 313-592-5000
www.demanddetroit.com

2 SPN 651/FMI 3 - EPA10

Injector Cylinder #1 Needle Control Valve Abnormal Operation (MAX)

Table 1.

SPN 651/FMI 3	
Description	This code will set when the Needle solenoid current response time does not meet requirement.
Monitored Parameter	Injector Cylinder #1 Needle Control Valve Current
Typical Enabling Conditions	Always enabled
Monitor Sequence	None
Execution Frequency	Continuous
Typical Duration	5 sec
Dash Lamps	MIL, CEL
Engine Reaction	Derate 25%, EGR Valve shut, DPF Inhibit Regeneration, Limit DEF dosing
Verification	Engine Idle (1 minute)

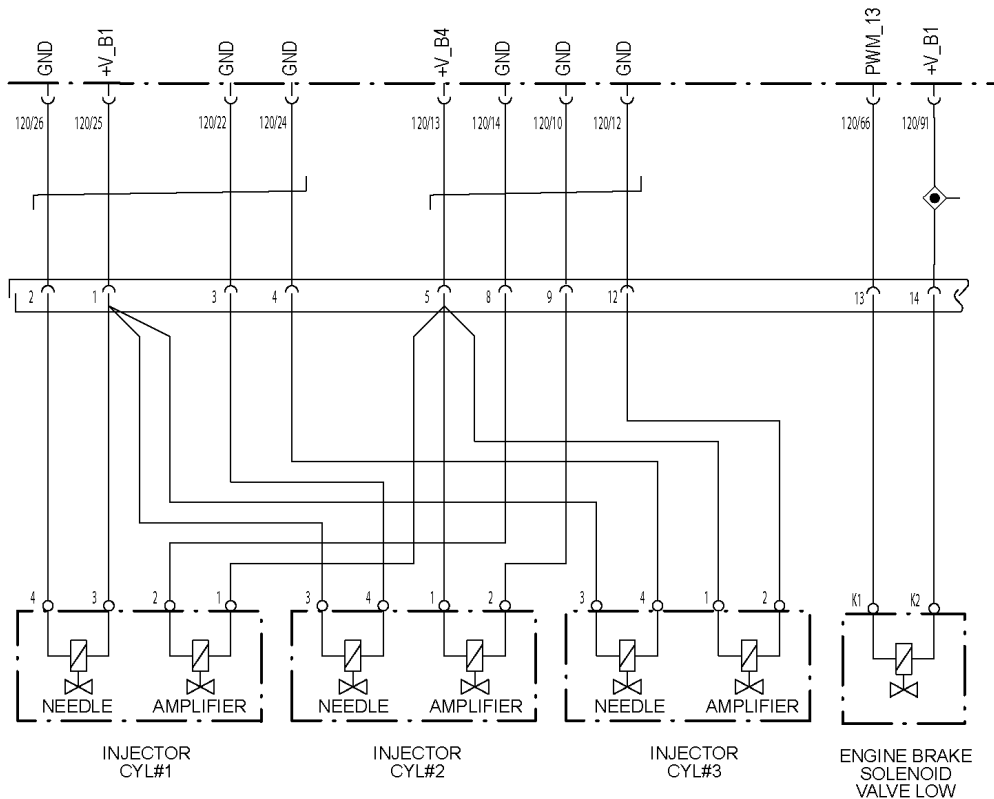

d150021

Check as follows:

NOTE: Submit completed diagnostics with warranty claim.

NOTE: Injector chart PDF available on DDCSN/SUPPORT/SPECIALIZED SERVICE.

1. Check for multiple codes. Using DiagnosticLink[®], retain log file of active fault and clear codes (code active for one key cycle).
 - a. If SPN fault code 168 or 723/FMI any is present, service those faults first.
 - b. If SPN fault code 168 or 723/FMI any is NOT present, Go to step 2.

**WARNING: ENGINE EXHAUST**

To avoid injury from inhaling engine exhaust, always operate the engine in a well-ventilated area. Engine exhaust is toxic.

**WARNING: PERSONAL INJURY**

To avoid injury before starting and running the engine, ensure the vehicle is parked on a level surface, parking brake is set, and the wheels are blocked.

2. Start and warm the engine until the coolant temperature is above 71°C (160°F).
3. Turn the engine OFF.
4. Disconnect the front fuel injector harness 14-pin injector connector.
5. Inspect the front fuel injector harness 14-pin injector connectors for bent or spread pins; inspect the connector seal for damage (signs of water or oil intrusion). Is there any damage found?
 - a. Yes; repair as necessary.
 - b. No; Go to step 6.

NOTE: DO NOT touch the metal ohmmeter leads with your hands when the measurements are made.

6. Using the appropriate chart below, measure and record the resistance values between the corresponding pins on the valve cover side of the front fuel injector harness listed below. Are the resistances within range?

Table 2.

Front Fuel Injector Harness 14-Pin Connector Resistance Chart (Valve Cover Side)				
Injector #1 Needle	Pins 1 and 2	Pins 1 and 8	Pin 2 and ground	Pin 8 and ground
	1.3 to 2.5Ω*	Greater than 100kΩ*	Greater than 100kΩ*	Greater than 100kΩ*
	Ω	Ω	Ω	Ω
Injector #2 Needle	Pins 1 and 3	Pins 1 and 9	Pin 3 and ground	Pin 9 and ground
	1.3 to 2.5Ω*	Greater than 100kΩ*	Greater than 100kΩ*	Greater than 100kΩ*
	Ω	Ω	Ω	Ω
Injector #3 Needle	Pins 1 and 4	Pins 1 and 12	Pin 4 and ground	Pin 12 and ground
	1.3 to 2.5Ω*	Greater than 100kΩ*	Greater than 100kΩ*	Greater than 100kΩ*
	Ω	Ω	Ω	Ω
* = acceptable resistance				

VALVE COVER SIDE

d540083

Table 3.

Front Fuel Injector Harness 14-Pin Connector Resistance Chart (Using J-48671-10 Injector Breakout Box)				
Note: Ensure J-48671-10 ground strap is connected to cylinder head.				
Injector #1 Needle	Pins 3 and 4	Pins 2 and 3	Pin 2 and ground	Pin 3 and ground
	1.3 to 2.5Ω*	Greater than 100kΩ*	Greater than 100kΩ*	Greater than 100kΩ*
	Ω	Ω	Ω	Ω
Injector #2 Needle	Pins 3 and 4	Pins 2 and 3	Pin 2 and ground	Pin 3 and ground
	1.3 to 2.5Ω*	Greater than 100kΩ*	Greater than 100kΩ*	Greater than 100kΩ*
	Ω	Ω	Ω	Ω
Injector #3 Needle	Pins 3 and 4	Pins 2 and 3	Pin 2 and ground	Pin 3 and ground
	1.3 to 2.5Ω*	Greater than 100kΩ*	Greater than 100kΩ*	Greater than 100kΩ*
	Ω	Ω	Ω	Ω
* = acceptable resistance				



- a. Yes; Go to step 12.
 - b. No; Go to step 7.
7. Remove the rocker cover. Refer to section "Removal of the Rocker Cover".
 8. Remove the front fuel injector harness from the engine.
Refer to section "Removal of the Two-Piece Fuel Injector Wiring Harness - Three-Filter System".
Refer to section "Removal of the Two-Piece Fuel Injector Wiring Harness - Two-Filter System".
- NOTE:** DO NOT touch the metal ohmmeter leads with your hands when the measurements are made.
9. Using the chart below, measure and record the resistance values between the injector pins listed below. Are the resistances within range?

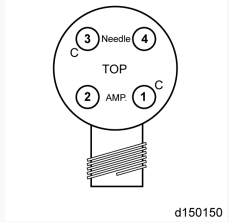

Table 4.

Injector Needle Resistance Chart (Injector Harness must be removed from engine)					
Injector #1 Needle	Pins 3 and 4	Pins 3 and 2	Pin 2 and ground	Pin 3 and ground	
	2.0Ω or less*	Greater than 100kΩ*	Greater than 100kΩ*	Greater than 100kΩ*	
	Ω	Ω	Ω	Ω	
Injector #2 Needle	Pins 3 and 4	Pins 3 and 2	Pin 2 and ground	Pin 3 and ground	
	2.0Ω or less*	Greater than 100kΩ*	Greater than 100kΩ*	Greater than 100kΩ*	
	Ω	Ω	Ω	Ω	
Injector #3 Needle	Pins 3 and 4	Pins 3 and 2	Pin 2 and ground	Pin 3 and ground	
	2.0Ω or less*	Greater than 100kΩ*	Greater than 100kΩ*	Greater than 100kΩ*	
	Ω	Ω	Ω	Ω	
* = acceptable resistance					



- a. Yes; replace the front fuel injector harness.
Refer to section "Removal of the Two-Piece Fuel Injector Wiring Harness - Three-Filter System".
Refer to section "Removal of the Two-Piece Fuel Injector Wiring Harness - Two-Filter System".
 - b. No; Go to step 10.
10. Inspect the Injector connector pins and determine whether they are copper or stainless steel. Are all the injectors on the front bank stainless steel?

Table 5.

 <p>d470321</p>	 <p>d470322</p>
Stainless Steel Terminals	Copper Alloy Terminals

- a. Yes; replace the injector with the out-of-range resistance.
Refer to section "Removal of the Fuel Injector - Three-Filter System".
Refer to section "Removal of the Fuel Injector - Two-Filter System".
 - b. No; Go to step 11.
11. Review the MCM Hardware Part Number on the sticker located on the front of the MCM, shown in the figure below. Is the MCM Hardware part number RA0014469935 or RA0024460135?

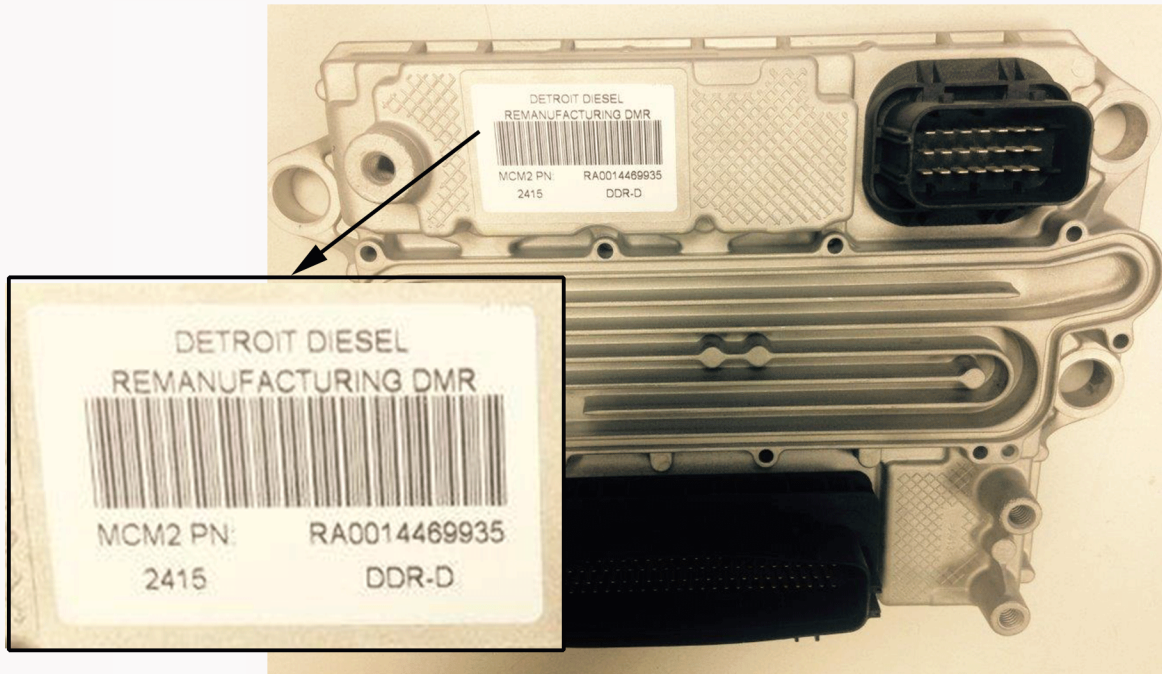

d540129

- a. Yes; replace all the copper connector pin injectors on the engine. Verify Repairs.
Refer to section "Removal of the Fuel Injector - Three-Filter System".
Refer to section "Removal of the Fuel Injector - Two-Filter System".
 - b. No; replace the MCM with MCM part number RA0014469935. Refer to section "Removal of the Motor Control Module". Verify repairs. See [15TS-16](http://ddcsn-ddc.freightliner.com/cps/rde/xbcr/ddcsn/15TS16.pdf) (<http://ddcsn-ddc.freightliner.com/cps/rde/xbcr/ddcsn/15TS16.pdf>) for further information.
12. Disconnect the Motor Control Module (MCM) 120-pin connector.
 13. Inspect the MCM 120-pin connector and 120-pin harness connector for signs of corrosion, spread, unseated (pushed out) or damaged pins, connector seal for damage (signs of water or oil intrusion) or signs of wire damage.
 - a. If signs of damage are found, repair as necessary. Verify repairs.
 - b. If no signs of damage, Go to step 14.

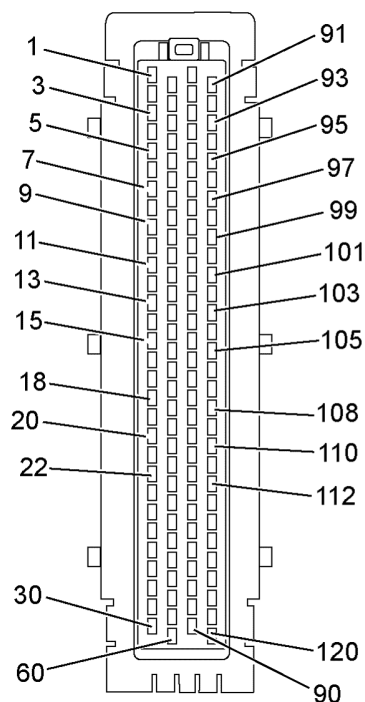

ENGINE HARNESS SIDE

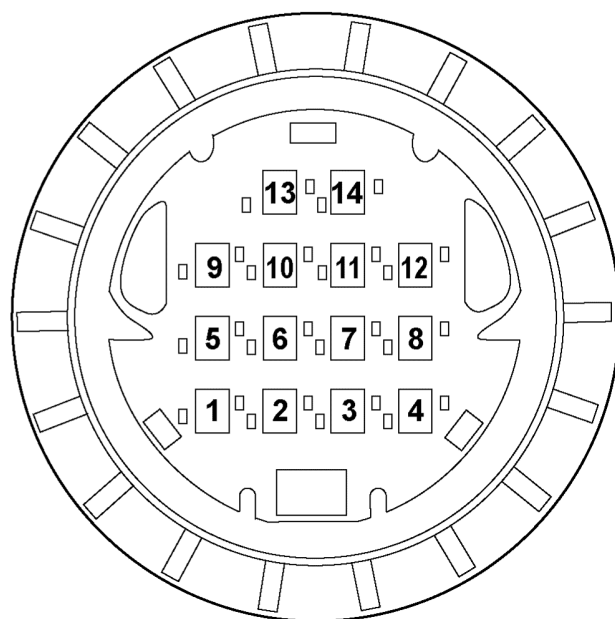

d540080

NOTE: DO NOT touch the metal ohmmeter leads with your hands when the measurements are made.

14. Using the chart below, measure and record the resistance values between the engine side of the front valve cover 14-pin connector and the MCM 120-pin connector. Are the resistances within range?

Table 6.

Engine Harness Injector Circuit Resistance Table				
Front Engine Side Valve Cover 14-pin connector #	MCM 120-Pin Harness Connector	Acceptable Resistance 1Ω or less	Front Engine Side Valve Cover 14 pin connector #	Acceptable Resistance 1KΩ or greater
1	25	Ω	1 and ground	Ω
2	26	Ω	2 and ground	Ω
3	22	Ω	3 and ground	Ω
4	24	Ω	4 and ground	Ω

- a. Yes; Go to step 15.
 b. No; repair the engine side harness. Verify repairs.
15. Review the MCM Hardware Part Number on the sticker located on the front of the MCM, shown in the figure below. Is the MCM Hardware part number RA0014469935 or RA0024460135?

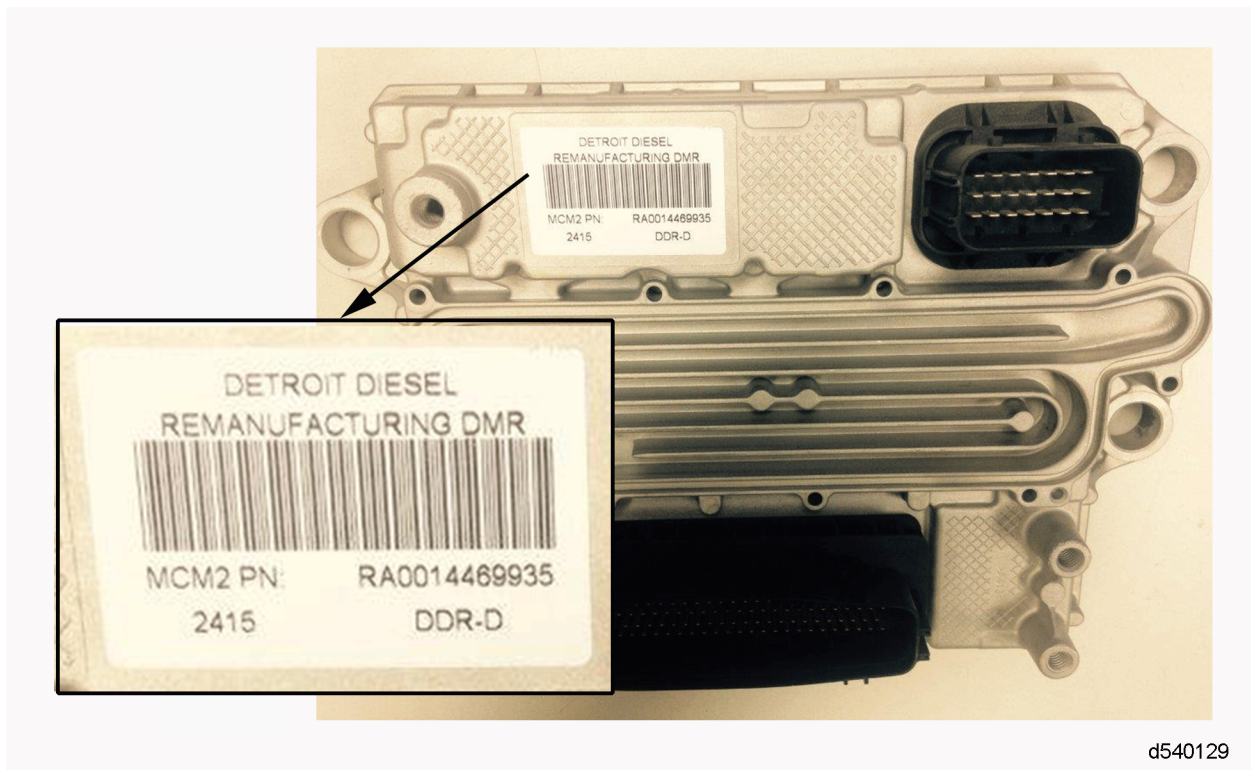

- a. Yes; replace all the copper connector pin injectors on the engine. Verify Repairs.
Refer to section "Removal of the Fuel Injector - Three-Filter System".
Refer to section "Removal of the Fuel Injector - Two-Filter System".
- b. No, replace the MCM with MCM part number RA0014469935. Refer to section "Removal of the Motor Control Module". Verify repairs. See [15TS-16](http://ddcsn-ddc.freightliner.com/cps/rde/xbcr/ddcsn/15TS16.pdf) (<http://ddcsn-ddc.freightliner.com/cps/rde/xbcr/ddcsn/15TS16.pdf>) for further information.

3 SPN 652/FMI 3 - EPA10

Injector Cylinder #2 Needle Control Valve Abnormal Operation (MAX)

Table 7.

SPN 652/FMI 3	
Description	This code will set when the Needle solenoid current response time does not meet requirement.
Monitored Parameter	Injector Cylinder #2 Needle Control Valve Current
Typical Enabling Conditions	Always enabled
Monitor Sequence	None
Execution Frequency	Continuous
Typical Duration	.02 msec
Dash Lamps	MIL, CEL
Engine Reaction	Derate 25%, EGR Valve shut, DPF Inhibit Regeneration, Limit DEF dosing
Verification	Engine Idle (1 minute)

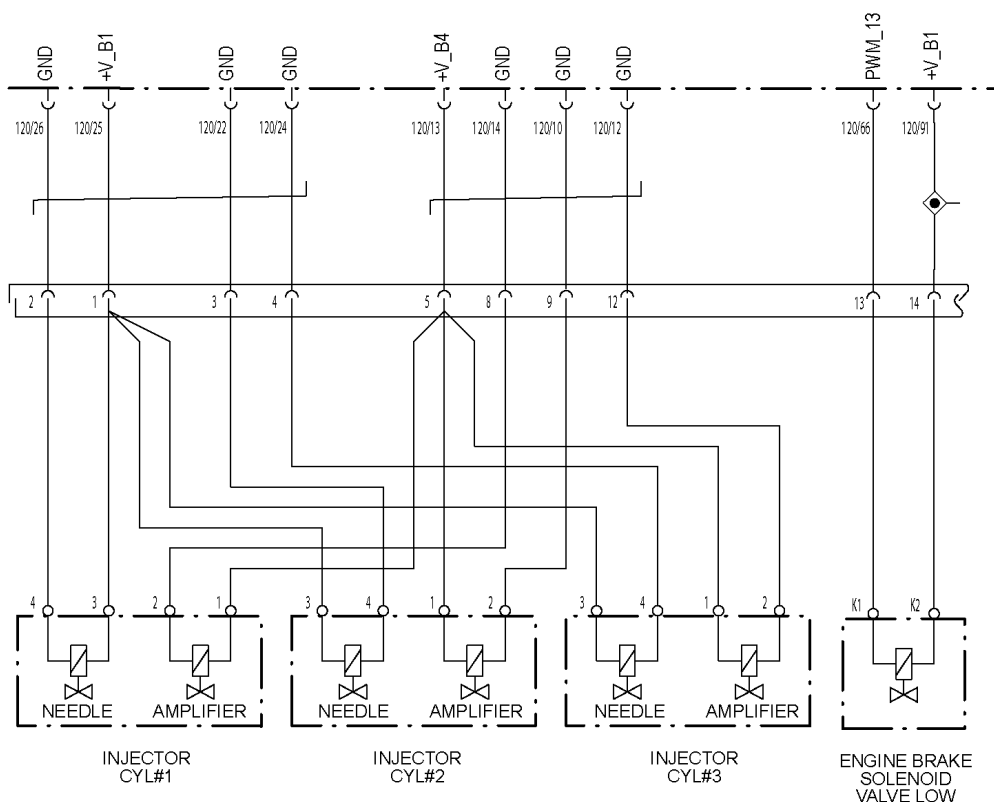

d150021

Check as follows:

NOTE: Submit completed diagnostics with warranty claim.

NOTE: Injector chart PDF available on DDASN/SUPPORT/SPECIALIZED SERVICE.

1. Check for multiple codes. Using DiagnosticLink[®], retain log file of active fault and clear codes (code active for one key cycle).
 - a. If SPN fault code 168 or 723/FMI any is present, service those faults first.
 - b. If SPN fault code 168 or 723/FMI any is NOT present, Go to step 2.



WARNING: ENGINE EXHAUST

To avoid injury from inhaling engine exhaust, always operate the engine in a well-ventilated area. Engine exhaust is toxic.



WARNING: PERSONAL INJURY

To avoid injury before starting and running the engine, ensure the vehicle is parked on a level surface, parking brake is set, and the wheels are blocked.

2. Start and warm the engine until the coolant temperature is above 71°C (160°F).
3. Turn the engine OFF.
4. Disconnect the front fuel injector harness 14-pin injector connector.
5. Inspect the front fuel injector harness 14-pin injector connectors for bent or spread pins; inspect the connector seal for damage (signs of water or oil intrusion). Is there any damage found?
 - a. Yes; repair as necessary
 - b. No; Go to step 6.

NOTE: DO NOT touch the metal ohmmeter leads with your hands when the measurements are made.

6. Using the appropriate chart below, measure and record the resistance values between the corresponding pins on the valve cover side of the front fuel injector harness listed below. Are the resistances within range?

Table 8.

Front Fuel Injector Harness 14-Pin Connector Resistance Chart (Valve Cover Side)				
Injector #1 Needle	Pins 1 and 2	Pins 1 and 8	Pin 2 and ground	Pin 8 and ground
	1.3 to 2.5Ω*	Greater than 100kΩ*	Greater than 100kΩ*	Greater than 100kΩ*
	Ω	Ω	Ω	Ω
Injector #2 Needle	Pins 1 and 3	Pins 1 and 9	Pin 3 and ground	Pin 9 and ground
	1.3 to 2.5Ω*	Greater than 100kΩ*	Greater than 100kΩ*	Greater than 100kΩ*
	Ω	Ω	Ω	Ω
Injector #3 Needle	Pins 1 and 4	Pins 1 and 12	Pin 4 and ground	Pin 12 and ground
	1.3 to 2.5Ω*	Greater than 100kΩ*	Greater than 100kΩ*	Greater than 100kΩ*
	Ω	Ω	Ω	Ω
* = acceptable resistance				

VALVE COVER SIDE

d540083

Table 9.

Front Fuel Injector Harness 14-Pin Connector Resistance Chart (Using J-48671-10 Injector Breakout Box)				
Note: Ensure J-48671-10 ground strap is connected to cylinder head.				
Injector #1 Needle	Pins 3 and 4	Pins 2 and 3	Pin 2 and ground	Pin 3 and ground
	1.3 to 2.5Ω*	Greater than 100kΩ*	Greater than 100kΩ*	Greater than 100kΩ*
	Ω	Ω	Ω	Ω
Injector #2 Needle	Pins 3 and 4	Pins 2 and 3	Pin 2 and ground	Pin 3 and ground
	1.3 to 2.5Ω*	Greater than 100kΩ*	Greater than 100kΩ*	Greater than 100kΩ*
	Ω	Ω	Ω	Ω
Injector #3 Needle	Pins 3 and 4	Pins 2 and 3	Pin 2 and ground	Pin 3 and ground
	1.3 to 2.5Ω*	Greater than 100kΩ*	Greater than 100kΩ*	Greater than 100kΩ*
	Ω	Ω	Ω	Ω
* = acceptable resistance				

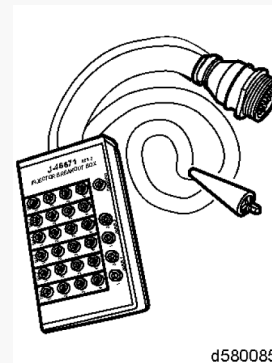

- a. Yes; Go to step 12.
- b. No; Go to step 7.

7. Remove the rocker cover. Refer to section "Removal of the Rocker Cover".
8. Remove the front fuel injector harness from the engine.
Refer to section "Removal of the Two-Piece Fuel Injector Wiring Harness - Three-Filter System".
Refer to section "Removal of the Two-Piece Fuel Injector Wiring Harness - Two-Filter System".

NOTE: DO NOT touch the metal ohmmeter leads with your hands when the measurements are made.

9. Using the chart below, measure and record the resistance values between the injector pins listed below. Are the resistances within range?

Table 10.

Injector Needle Resistance Chart (Injector Harness must be removed from engine)					
Injector #1 Needle	Pins 3 and 4	Pins 3 and 2	Pin 2 and ground	Pin 3 and ground	
	2.0Ω or less*	Greater than 100kΩ*	Greater than 100kΩ*	Greater than 100kΩ*	
	Ω	Ω	Ω	Ω	
Injector #2 Needle	Pins 3 and 4	Pins 3 and 2	Pin 2 and ground	Pin 3 and ground	
	2.0Ω or less*	Greater than 100kΩ*	Greater than 100kΩ*	Greater than 100kΩ*	
	Ω	Ω	Ω	Ω	
Injector #3 Needle	Pins 3 and 4	Pins 3 and 2	Pin 2 and ground	Pin 3 and ground	
	2.0Ω or less*	Greater than 100kΩ*	Greater than 100kΩ*	Greater than 100kΩ*	
	Ω	Ω	Ω	Ω	
* = acceptable resistance					

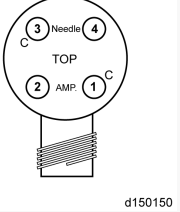

- a. Yes; replace the front fuel injector harness.
Refer to section "Removal of the Two-Piece Fuel Injector Wiring Harness - Three-Filter System".
Refer to section "Removal of the Two-Piece Fuel Injector Wiring Harness - Two-Filter System".
 - b. No; Go to step 10.
10. Inspect the Injector connector pins and determine whether they are copper or stainless steel. Are all the injectors on the front bank stainless steel?

Table 11.

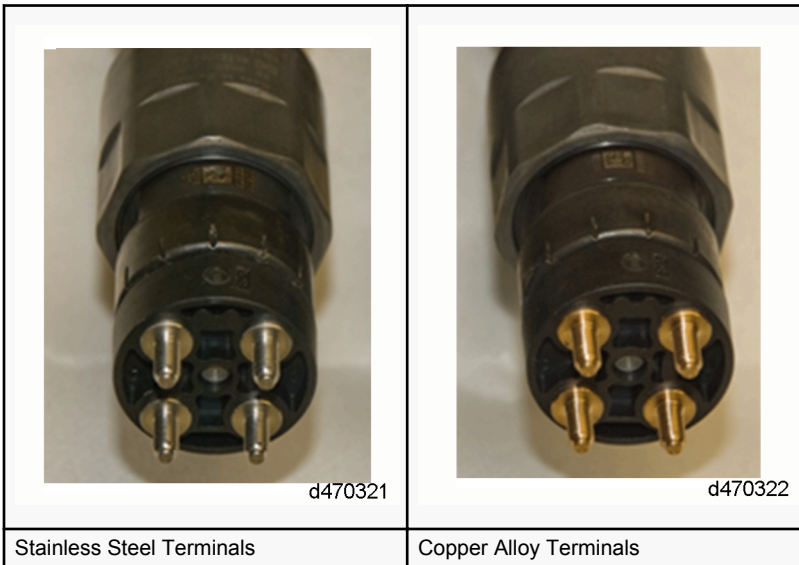

- a. Yes; replace the injector with the out-of-range resistance.
Refer to section "Removal of the Two-Piece Fuel Injector Wiring Harness - Three-Filter System".
Refer to section "Removal of the Two-Piece Fuel Injector Wiring Harness - Two-Filter System".
 - b. No; Go to step 11.
11. Review the MCM Hardware Part Number on the sticker located on the front of the MCM, shown in the figure below. Is the MCM Hardware part number RA0014469935 or RA0024460135?



d540129

- a. Yes; replace all the copper connector pin injectors on the engine . Verify Repairs.
Refer to section "Removal of the Fuel Injector - Three-Filter System".
Refer to section "Removal of the Fuel Injector - Two-Filter System".
 - b. No; replace the MCM with MCM part number RA0014469935. Refer to section "Removal of the Motor Control Module". Verify repairs. See [15TS-16](http://ddcsn-ddc.freightliner.com/cps/rde/xbcr/ddcsn/15TS16.pdf) (<http://ddcsn-ddc.freightliner.com/cps/rde/xbcr/ddcsn/15TS16.pdf>) for further information.
12. Disconnect the Motor Control Module (MCM) 120-pin connector.
 13. Inspect the MCM 120-pin connector and 120-pin harness connector for signs of corrosion, spread, unseated (pushed out) or damaged pins, connector seal for damage (signs of water or oil intrusion) or signs of wire damage.
 - a. If signs of damage are found, repair as necessary. Verify repairs.
 - b. If no signs of damage, Go to step 14.

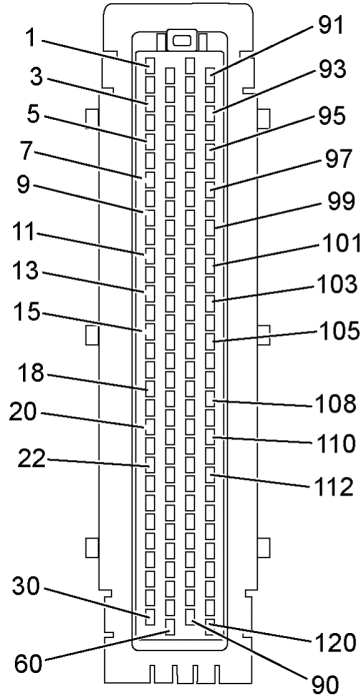

ENGINE HARNESS SIDE

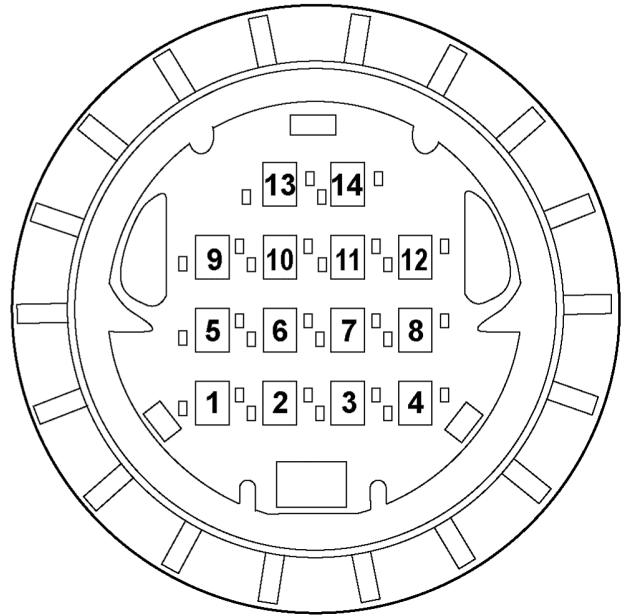

d540080

NOTE: DO NOT touch the metal ohmmeter leads with your hands when the measurements are made.

14. Using the chart below, measure and record the resistance values between the engine side of the front valve cover 14-pin connector and the MCM 120-pin connector. Are the resistances within range?

Table 12.

Engine Harness Injector Circuit Resistance Table				
Front Engine Side Valve Cover 14-pin connector #	MCM 120-Pin Harness Connector	Acceptable Resistance 1Ω or less	Front Engine Side Valve Cover 14 pin connector #	Acceptable Resistance 1KΩ or greater
1	25	Ω	1 and ground	Ω
2	26	Ω	2 and ground	Ω
3	22	Ω	3 and ground	Ω
4	24	Ω	4 and ground	Ω

- a. Yes; Go to step 15.
 - b. No; repair the engine side harness. Verify repairs.
15. Review the MCM Hardware Part Number on the sticker located on the front of the MCM, under the Instrumentation window in DiagnosticLink as shown in the figure below. Is the MCM Hardware part number RA0014469935 or RA0024460135?

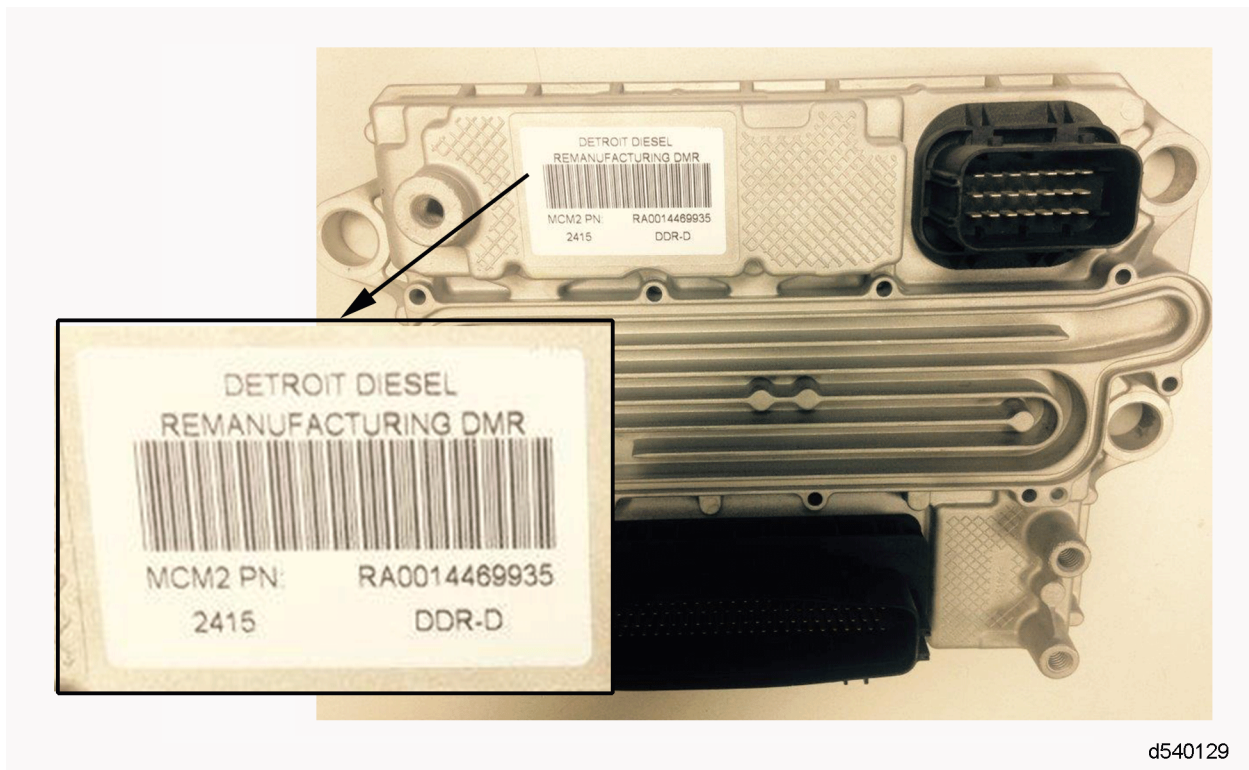

- a. Yes; replace all the copper connector pin injectors on the engine. Verify repairs.
Refer to section "Removal of the Fuel Injector - Three-Filter System".
Refer to section "Removal of the Fuel Injector - Two-Filter System".
- b. No, replace the MCM with MCM part number RA0014469935. Refer to section "Removal of the Motor Control Module" . Verify repairs. See [15TS-16](http://ddcsn-ddc.freightliner.com/cps/rde/xbcr/ddcsn/15TS16.pdf) (<http://ddcsn-ddc.freightliner.com/cps/rde/xbcr/ddcsn/15TS16.pdf>) for further information.

4 SPN 653/FMI 3 - EPA10

Injector Cylinder #3 Needle Control Valve Abnormal Operation (MAX)

Table 13.

SPN 653/FMI 3	
Description	This code will set when the Needle solenoid current response time does not meet requirement
Monitored Parameter	Injector Cylinder #3 Needle Control Valve Current
Typical Enabling Conditions	Always enabled
Monitor Sequence	None
Execution Frequency	Continuous
Typical Duration	.02 msec
Dash Lamps	MIL, CEL
Engine Reaction	Derate 25%, EGR Valve shut, DPF Inhibit Regeneration, Limit DEF dosing
Verification	Engine Idle (1 minute)

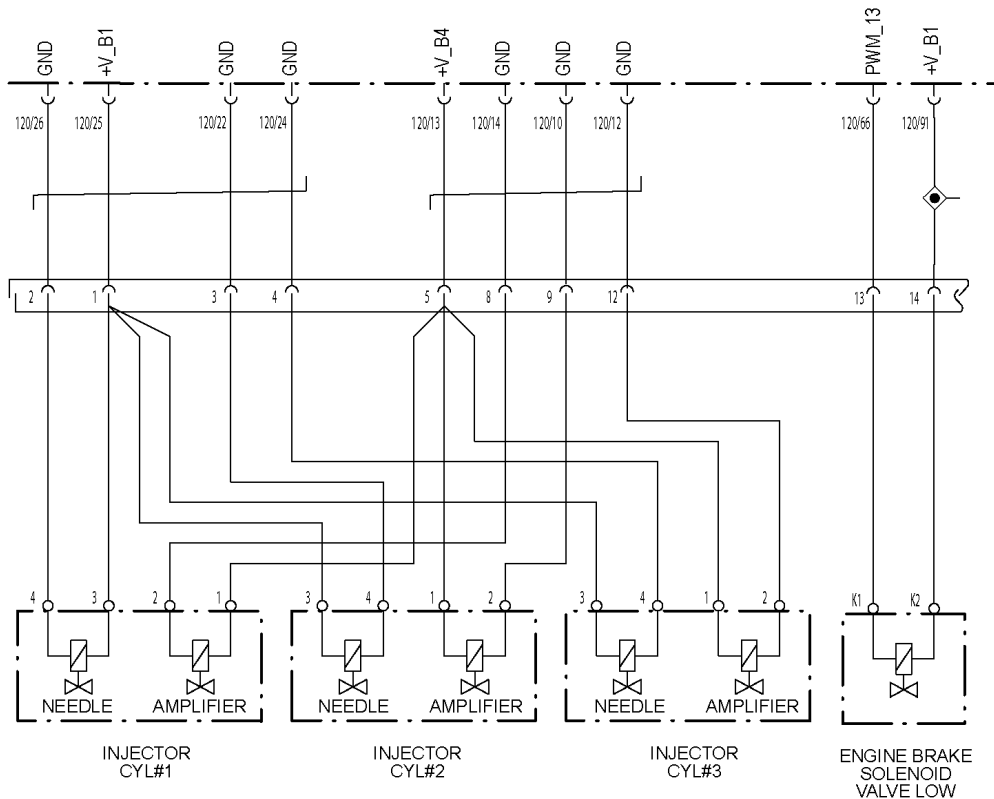

d150021

Check as follows:

NOTE: Submit completed diagnostics with warranty claim.

NOTE: Injector chart PDF available on DDCSN/SUPPORT/SPECIALIZED SERVICE.

1. Check for multiple codes. Using DiagnosticLink[®], retain log file of active fault and clear codes (code active for one key cycle).
 - a. If SPN fault code 168 or 723/FMI any is present, service those faults first.
 - b. If SPN fault code 168 or 723/FMI any is NOT present, Go to step 2.

**WARNING: PERSONAL INJURY**

To avoid injury before starting and running the engine, ensure the vehicle is parked on a level surface, parking brake is set, and the wheels are blocked.

**WARNING: ENGINE EXHAUST**

To avoid injury from inhaling engine exhaust, always operate the engine in a well-ventilated area. Engine exhaust is toxic.

2. Start and warm the engine until the coolant temperature is above 71°C (160°F).
3. Turn the engine OFF.
4. Disconnect the front fuel injector harness 14-pin injector connector.
5. Inspect the front fuel injector harness 14-pin injector connectors for bent or spread pins; inspect the connector seal for damage (signs of water or oil intrusion). Is there any damage found?
 - a. Yes; repair as necessary.
 - b. No; Go to step 6.

NOTE: DO NOT touch the metal ohmmeter leads with your hands when the measurements are made.

6. Using the appropriate chart below, measure and record the resistance values between the corresponding pins on the valve cover side of the front fuel injector harness listed below. Are the resistances within range?

Table 14.

Front Fuel Injector Harness 14-Pin Connector Resistance Chart (Valve Cover Side)				
Injector #1 Needle	Pins 1 and 2	Pins 1 and 8	Pin 2 and ground	Pin 8 and ground
	1.3 to 2.5Ω*	Greater Than 100kΩ*	Greater Than 100kΩ*	Greater Than 100kΩ*
	Ω	Ω	Ω	Ω
Injector #2 Needle	Pins 1 and 3	Pins 1 and 9	Pin 3 and ground	Pin 9 and ground
	1.3 to 2.5Ω*	Greater Than 100kΩ*	Greater Than 100kΩ*	Greater Than 100kΩ*
	Ω	Ω	Ω	Ω
Injector #3 Needle	Pins 1 and 4	Pins 1 and 12	Pin 4 and ground	Pin 12 and ground
	1.3 to 2.5Ω*	Greater Than 100kΩ*	Greater Than 100kΩ*	Greater Than 100kΩ*
	Ω	Ω	Ω	Ω
* = acceptable resistance				

VALVE COVER SIDE

d540083

Table 15.

Front Fuel Injector Harness 14-Pin Connector Resistance Chart (Using J-48671-10 Injector Breakout Box)				
Note: Ensure J-48671-10 ground strap is connected to cylinder head.				
Injector #1 Needle	Pins 3 and 4	Pins 2 and 3	Pin 2 and ground	Pin 3 and ground
	1.3 to 2.5Ω*	Greater Than 100kΩ*	Greater Than 100kΩ*	Greater Than 100kΩ*
	Ω	Ω	Ω	Ω
Injector #2 Needle	Pins 3 and 4	Pins 2 and 3	Pin 2 and ground	Pin 3 and ground
	1.3 to 2.5Ω*	Greater Than 100kΩ*	Greater Than 100kΩ*	Greater Than 100kΩ*
	Ω	Ω	Ω	Ω
Injector #3 Needle	Pins 3 and 4	Pins 2 and 3	Pin 2 and ground	Pin 3 and ground
	1.3 to 2.5Ω*	Greater Than 100kΩ*	Greater Than 100kΩ*	Greater Than 100kΩ*
	Ω	Ω	Ω	Ω
* = acceptable resistance				



- a. Yes; Go to step 12.
 - b. No; Go to step 7.
7. Remove the rocker cover. Refer to section "Removal of the Rocker Cover".
 8. Remove the front fuel injector harness from the engine.
Refer to section "Removal of the Two-Piece Fuel Injector Wiring Harness - Three-Filter System".
Refer to section "Removal of the Two-Piece Fuel Injector Wiring Harness - Two-Filter System".
- NOTE:** DO NOT touch the metal ohmmeter leads with your hands when the measurements are made.
9. Using the chart below, measure and record the resistance values between the injector pins listed below. Are the resistances within range?

Table 16.

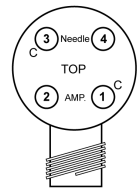

Injector Needle Resistance Chart (Injector Harness must be removed from engine)					
Injector #1 Needle	Pins 3 and 4	Pins 3 and 2	Pin 2 and ground	Pin 3 and ground	
	2.0Ω or less*	Greater Than 100kΩ*	Greater Than 100kΩ*	Greater Than 100kΩ*	
	Ω	Ω	Ω	Ω	
Injector #2 Needle	Pins 3 and 4	Pins 3 and 2	Pin 2 and ground	Pin 3 and ground	
	2.0Ω or less*	Greater Than 100kΩ*	Greater Than 100kΩ*	Greater Than 100kΩ*	
	Ω	Ω	Ω	Ω	
Injector #3 Needle	Pins 3 and 4	Pins 3 and 2	Pin 2 and ground	Pin 3 and ground	
	2.0Ω or less*	Greater Than 100kΩ*	Greater Than 100kΩ*	Greater Than 100kΩ*	
	Ω	Ω	Ω	Ω	
* = acceptable resistance					



d150150

- a. Yes; replace the front fuel injector harness.
Refer to section "Removal of the Two-Piece Fuel Injector Wiring Harness - Three-Filter System".
Refer to section "Removal of the Two-Piece Fuel Injector Wiring Harness - Two-Filter System".
 - b. No; Go to step 10.
10. Inspect the Injector connector pins and determine whether they are copper or stainless steel. Are all the injectors on the front bank stainless steel?

Table 17.

 <p style="text-align: center; font-size: small;">d470321</p>	 <p style="text-align: center; font-size: small;">d470322</p>
Stainless Steel Terminals	Copper Alloy Terminals

- a. Yes; replace the injector with the out-of-range resistance.
Refer to section "Removal of the Fuel Injector - Three-Filter System"
Refer to section "Removal of the Fuel Injector - Two-Filter System"
 - b. No; Go to step 11.
11. Review the MCM Hardware Part Number on the sticker located on the front of the MCM, shown in the figure below. Is the MCM Hardware part number RA0014469935 or RA0024460135?

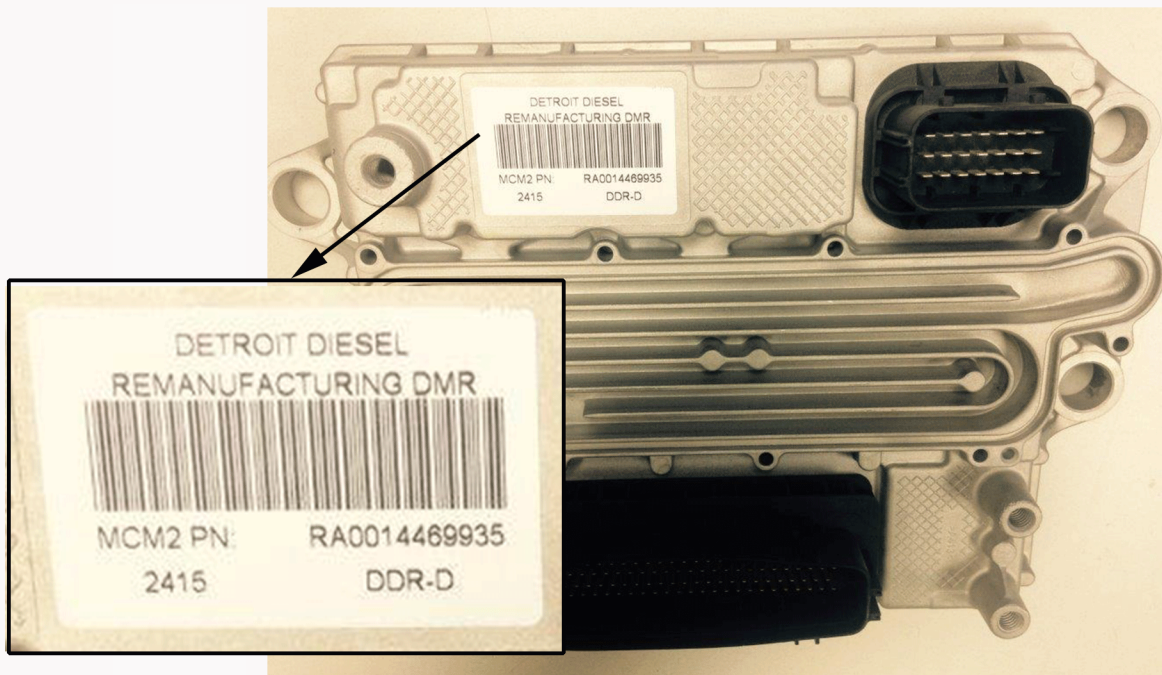

d540129

- a. Yes; replace all the copper connector pin injectors on the engine. Verify Repairs.
Refer to section "Removal of the Fuel Injector - Three-Filter System".
Refer to section "Removal of the Fuel Injector - Two-Filter System".
 - b. No; replace the MCM with MCM part number RA0014469935. Refer to section "Removal of the Motor Control Module" . Verify repairs. See [15TS-16](http://ddcsn-ddc.freightliner.com/cps/rde/xbcr/ddcsn/15TS16.pdf) (<http://ddcsn-ddc.freightliner.com/cps/rde/xbcr/ddcsn/15TS16.pdf>) for further information.
12. Disconnect the Motor Control Module (MCM) 120-pin connector.
 13. Inspect the MCM 120-pin connector and 120-pin harness connector for signs of corrosion, spread, unseated (pushed out) or damaged pins, connector seal for damage (signs of water or oil intrusion) or signs of wire damage.
 - a. If signs of damage are found, repair as necessary. Verify repairs.
 - b. If no signs of damage, Go to step 14.

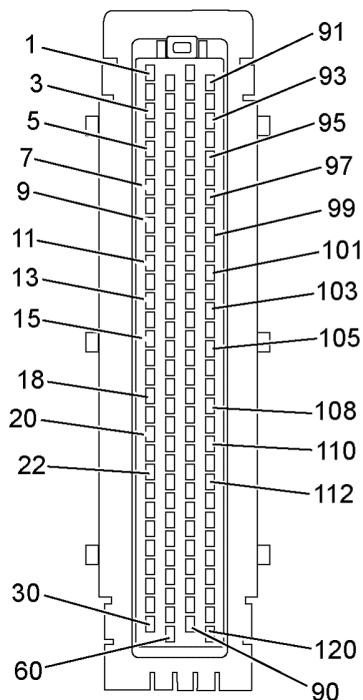

ENGINE HARNESS SIDE

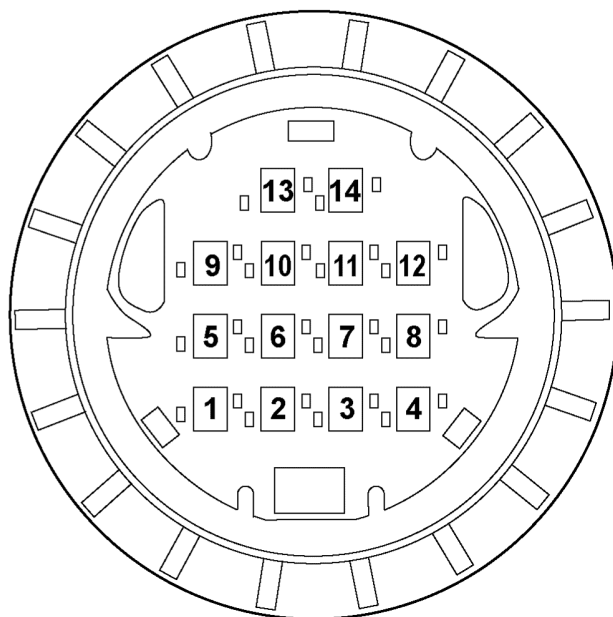

d540080

NOTE: DO NOT touch the metal ohmmeter leads with your hands when the measurements are made.

14. Using the chart below, measure and record the resistance values between the engine side of the front valve cover 14-pin connector and the MCM 120-pin connector. Are the resistances within range?

Table 18.

Engine Harness Injector Circuit Resistance Table				
Front Engine Side Valve Cover 14-pin connector #	MCM 120-Pin Harness Connector	Acceptable Resistance 1Ω or less	Front Engine Side Valve Cover 14 pin connector #	Acceptable Resistance 1KΩ or greater
1	25	Ω	1 and ground	Ω
2	26	Ω	2 and ground	Ω
3	22	Ω	3 and ground	Ω
4	24	Ω	4 and ground	Ω

- a. Yes; Go to step 15.
 - b. No; repair the engine side harness. Verify repairs.
15. Review the MCM Hardware Part Number on the sticker located on the front of the MCM, under the Instrumentation window in DiagnosticLink as shown in the figure below. Is the MCM Hardware part number RA0014469935 or RA0024460135?

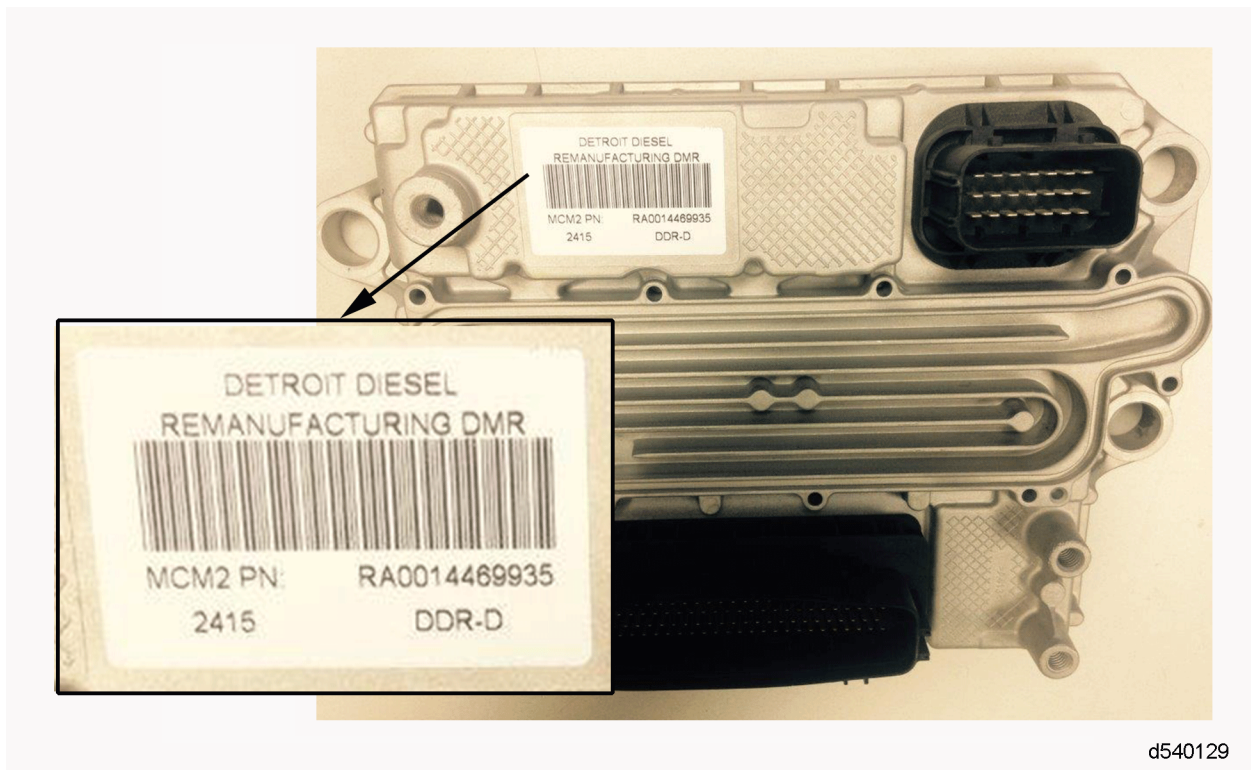

- a. Yes; replace all the copper connector pin injectors on the engine. Verify Repairs.
Refer to section "Removal of the Fuel Injector - Three-Filter System".
Refer to section "Removal of the Fuel Injector - Two-Filter System".
- b. No; replace the MCM with MCM part number RA0014469935. Refer to section "Removal of the Motor Control Module". Verify repairs. See [15TS-16 \(http://ddcsn-ddc.freightliner.com/cps/rde/xbcr/ddcsn/15TS16.pdf\)](http://ddcsn-ddc.freightliner.com/cps/rde/xbcr/ddcsn/15TS16.pdf) for further information.

5 SPN 654/FMI 3 - EPA10

Injector Cylinder #4 Needle Control Valve Abnormal Operation (MAX)

Table 19.

SPN 654/FMI 3	
Description	This code will set when the Needle solenoid current response time does not meet requirement.
Monitored Parameter	Injector Cylinder #4 Needle Control Valve Current
Typical Enabling Conditions	Always enabled
Monitor Sequence	None
Execution Frequency	Continuous
Typical Duration	.02 msec
Dash Lamps	MIL, CEL
Engine Reaction	Derate 25% , EGR Valve shut, DPF Inhibit Regeneration, Limit DEF dosing
Verification	Engine Idle (1 minute)

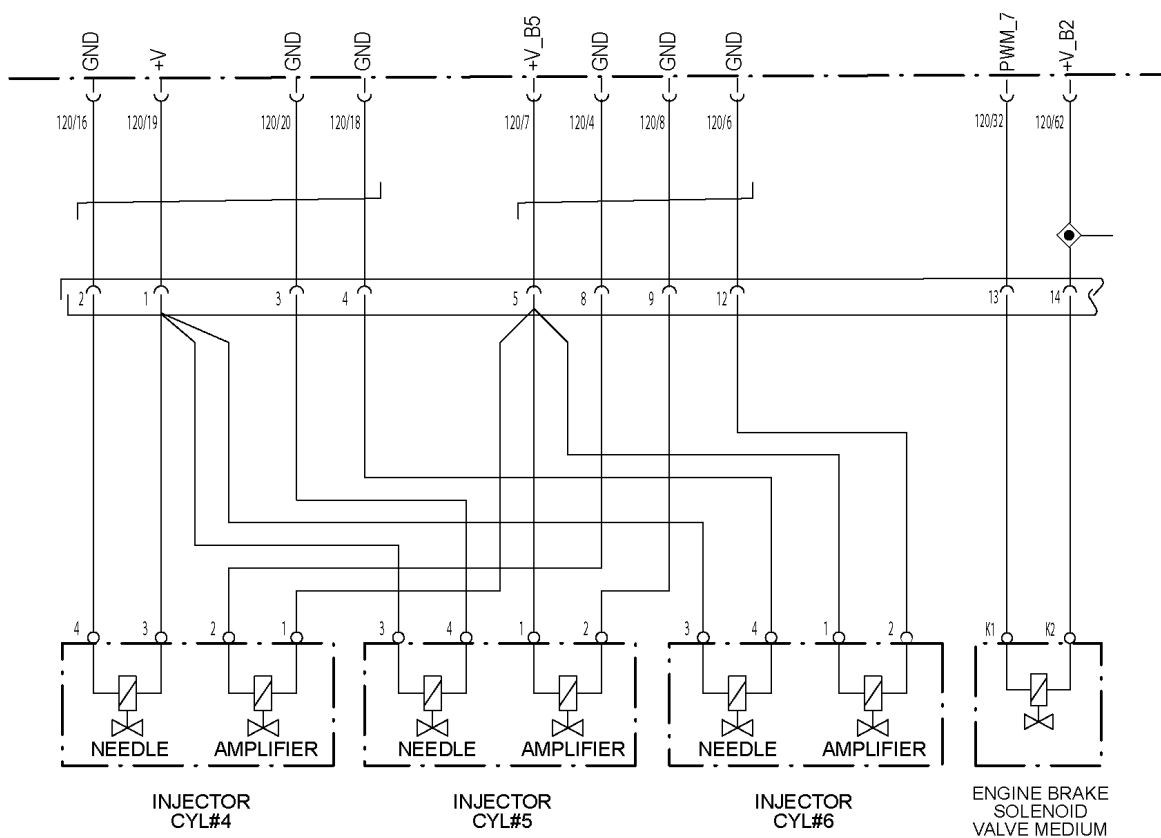

d150022

Check as follows:

NOTE: Submit completed diagnostics with warranty claim.

NOTE: Injector chart PDF available on DDCSN/SUPPORT/SPECIALIZED SERVICE.

1. Check for multiple codes. Using DiagnosticLink[®], retain log file of active fault and clear codes (code active for one key cycle).
 - a. If SPN fault code 168 or 723/FMI any is present, service those faults first.
 - b. If SPN fault code 168 or 723/FMI any is NOT present, Go to step 2.



WARNING: ENGINE EXHAUST

To avoid injury from inhaling engine exhaust, always operate the engine in a well-ventilated area. Engine exhaust is toxic.



WARNING: PERSONAL INJURY

To avoid injury before starting and running the engine, ensure the vehicle is parked on a level surface, parking brake is set, and the wheels are blocked.

2. Start and warm the engine until the coolant temperature is above 71°C (160°F).
3. Turn the engine OFF.
4. Disconnect the rear fuel injector harness 14-pin injector connector.
5. Inspect the rear fuel injector harness 14-pin injector connectors for bent or spread pins; inspect the connector seal for damage (signs of water or oil intrusion). Is there any damage found?
 - a. Yes; repair as necessary.
 - b. No; Go to step 6.

NOTE: DO NOT touch the metal ohmmeter leads with your hands when the measurements are made.

6. Using the appropriate chart below, measure and record the resistance values between the corresponding pins on the valve cover side of the rear fuel injector harness listed below. Are the resistances within range?

Table 20.

Rear Fuel Injector Harness 14-Pin Connector Resistance Chart (Valve Cover Side)				
Injector #4 Needle	Pins 1 and 2	Pins 1 and 8	Pin 2 and ground	Pin 8 and ground
	1.3 to 2.5Ω*	Greater than 100kΩ*	Greater than 100kΩ*	Greater than 100kΩ*
	Ω	Ω	Ω	Ω
Injector #5 Needle	Pins 1 and 3	Pins 1 and 9	Pin 3 and ground	Pin 9 and ground
	1.3 to 2.5Ω*	Greater than 100kΩ*	Greater than 100kΩ*	Greater than 100kΩ*
	Ω	Ω	Ω	Ω
Injector #6 Needle	Pins 1 and 4	Pins 1 and 12	Pin 4 and ground	Pin 12 and ground
	1.3 to 2.5Ω*	Greater than 100kΩ*	Greater than 100kΩ*	Greater than 100kΩ*
	Ω	Ω	Ω	Ω
* = acceptable resistance				

VALVE COVER SIDE

d540083

Table 21.

Rear Fuel Injector Harness 14-Pin Connector Resistance Chart (Using J-48671-10 Injector Breakout Box)				
Note: Ensure J-48671-10 ground strap is connected to cylinder head.				
Injector #4 Needle	Pins 3 and 4	Pins 2 and 3	Pin 2 and ground	Pin 3 and ground
	1.3 to 2.5Ω*	Greater than 100kΩ*	Greater than 100kΩ*	Greater than 100kΩ*
	Ω	Ω	Ω	Ω
Injector #5 Needle	Pins 3 and 4	Pins 2 and 3	Pin 2 and ground	Pin 3 and ground
	1.3 to 2.5Ω*	Greater than 100kΩ*	Greater than 100kΩ*	Greater than 100kΩ*
	Ω	Ω	Ω	Ω
Injector #6 Needle	Pins 3 and 4	Pins 2 and 3	Pin 2 and ground	Pin 3 and ground
	1.3 to 2.5Ω*	Greater than 100kΩ*	Greater than 100kΩ*	Greater than 100kΩ*
	Ω	Ω	Ω	Ω
* = acceptable resistance				

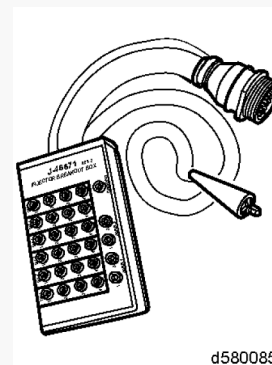

- a. Yes; Go to step 12.
- b. No; Go to step 7.

7. Remove the rocker cover. Refer to section "Removal of the Rocker Cover".
8. Remove the rear fuel injector harness from the engine.
Refer to section "Removal of the Two-Piece Fuel Injector Wiring Harness - Three-Filter System".
Refer to section "Removal of the Two-Piece Fuel Injector Wiring Harness - Two-Filter System".

NOTE: DO NOT touch the metal ohmmeter leads with your hands when the measurements are made.

9. Using the chart below, measure and record the resistance values between the injector pins listed below. Are the resistances within range?

Table 22.

Injector Needle Resistance Chart (Injector Harness must be removed from engine)					
Injector #4 Needle	Pins 3 and 4	Pins 2 and 3	Pin 2 and ground	Pin 3 and ground	
	2.0Ω or less*	Greater than 100kΩ*	Greater than 100kΩ*	Greater than 100kΩ*	
	Ω	Ω	Ω	Ω	
Injector #5 Needle	Pins 3 and 4	Pins 2 and 3	Pin 2 and ground	Pin 3 and ground	
	2.0Ω or less*	Greater than 100kΩ*	Greater than 100kΩ*	Greater than 100kΩ*	
	Ω	Ω	Ω	Ω	
Injector #6 Needle	Pins 3 and 4	Pins 2 and 3	Pin 2 and ground	Pin 3 and ground	
	2.0Ω or less*	Greater than 100kΩ*	Greater than 100kΩ*	Greater than 100kΩ*	
	Ω	Ω	Ω	Ω	
* = acceptable resistance					

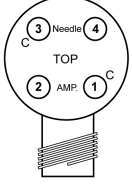

d150150

- a. Yes; replace the rear fuel injector harness.
 Refer to section "Removal of the Two-Piece Fuel Injector Wiring Harness - Three-Filter System".
 Refer to section "Removal of the Two-Piece Fuel Injector Wiring Harness - Two-Filter System".
 - b. No; Go to step 10.
10. Inspect the Injector connector pins and determine whether they are copper or stainless steel. Are all the injectors on the rear bank stainless steel?

Table 23.

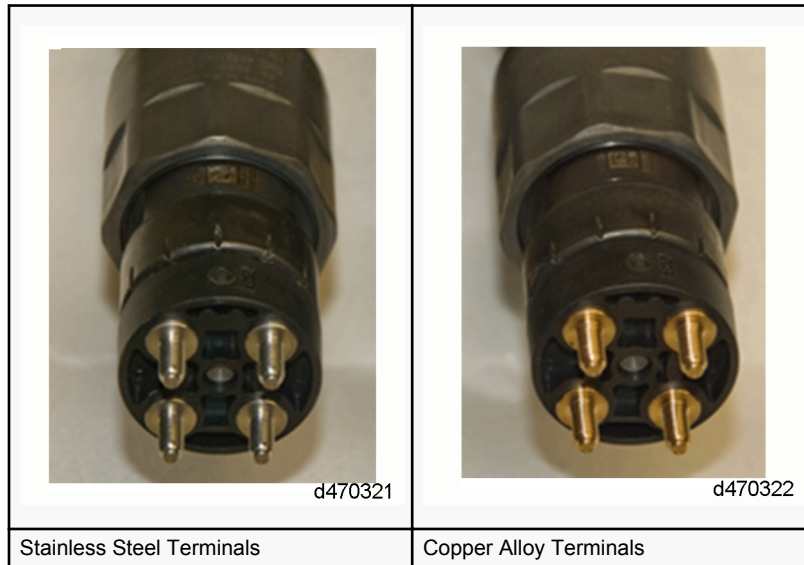

- a. Yes; replace the injector with the out-of-range resistance.
 Refer to section "Removal of the Fuel Injector - Three-Filter System".
 Refer to section "Removal of the Fuel Injector - Two-Filter System".
 - b. No; Go to step 11.
11. Review the MCM Hardware Part Number on the sticker located on the front of the MCM, shown in the figure below. Is the MCM Hardware part number RA0014469935 or RA0024460135?



d540129

- a. Yes; replace all the copper connector pin injectors on the engine. Verify Repairs.
Refer to section "Removal of the Fuel Injector - Three-Filter System".
Refer to section "Removal of the Fuel Injector - Two-Filter System".
 - b. No; replace the MCM with MCM part number RA0014469935. Refer to section "Removal of the Motor Control Module". Verify repairs. See [15TS-16](http://ddcsn-ddc.freightliner.com/cps/rde/xbcr/ddcsn/15TS16.pdf) (<http://ddcsn-ddc.freightliner.com/cps/rde/xbcr/ddcsn/15TS16.pdf>) for further information.
12. Disconnect the Motor Control Module (MCM) 120-pin connector.
 13. Inspect the MCM 120-pin connector and 120-pin harness connector for signs of corrosion, spread, unseated (pushed out) or damaged pins, connector seal for damage (signs of water or oil intrusion) or signs of wire damage.
 - a. If signs of damage are found, repair as necessary. Verify repairs.
 - b. If no signs of damage, Go to step 14.

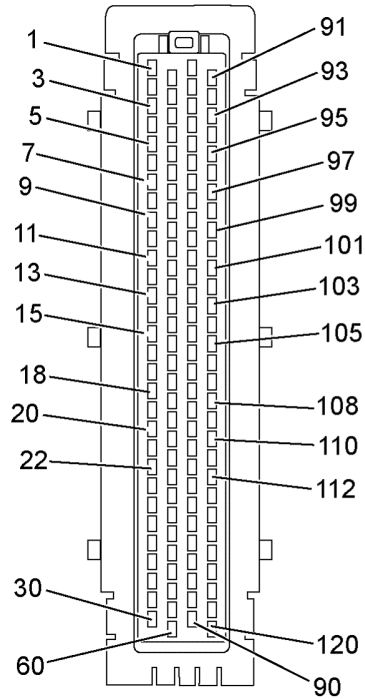

ENGINE HARNESS SIDE

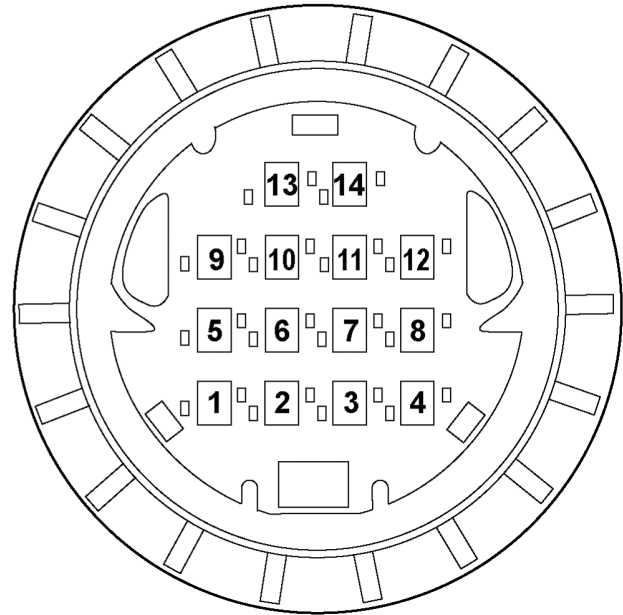

d540080

NOTE: DO NOT touch the metal ohmmeter leads with your hands when the measurements are made.

14. Using the chart below, measure and record the resistance values between the engine side of the front valve cover 14-pin connector and the MCM 120-pin connector. Are the resistances within range?

Table 24.

Engine Harness Injector Circuit Resistance Table				
Rear Engine Side Valve Cover 14-pin connector #	MCM 120-Pin Harness Connector	Acceptable Resistance 1Ω or less	Rear Engine Side Valve Cover 14 pin connector #	Acceptable Resistance 1KΩ or greater
1	19	Ω	1 and ground	Ω
2	16	Ω	2 and ground	Ω
3	20	Ω	3 and ground	Ω
4	18	Ω	4 and ground	Ω

- a. Yes; Go to step 15.
 - b. No; repair the engine side harness. Verify repairs.
15. Review the MCM Hardware Part Number on the sticker located on the front of the MCM, under the Instrumentation window in DiagnosticLink as shown in the figure below. Is the MCM Hardware part number RA0014469935 or RA0024460135?

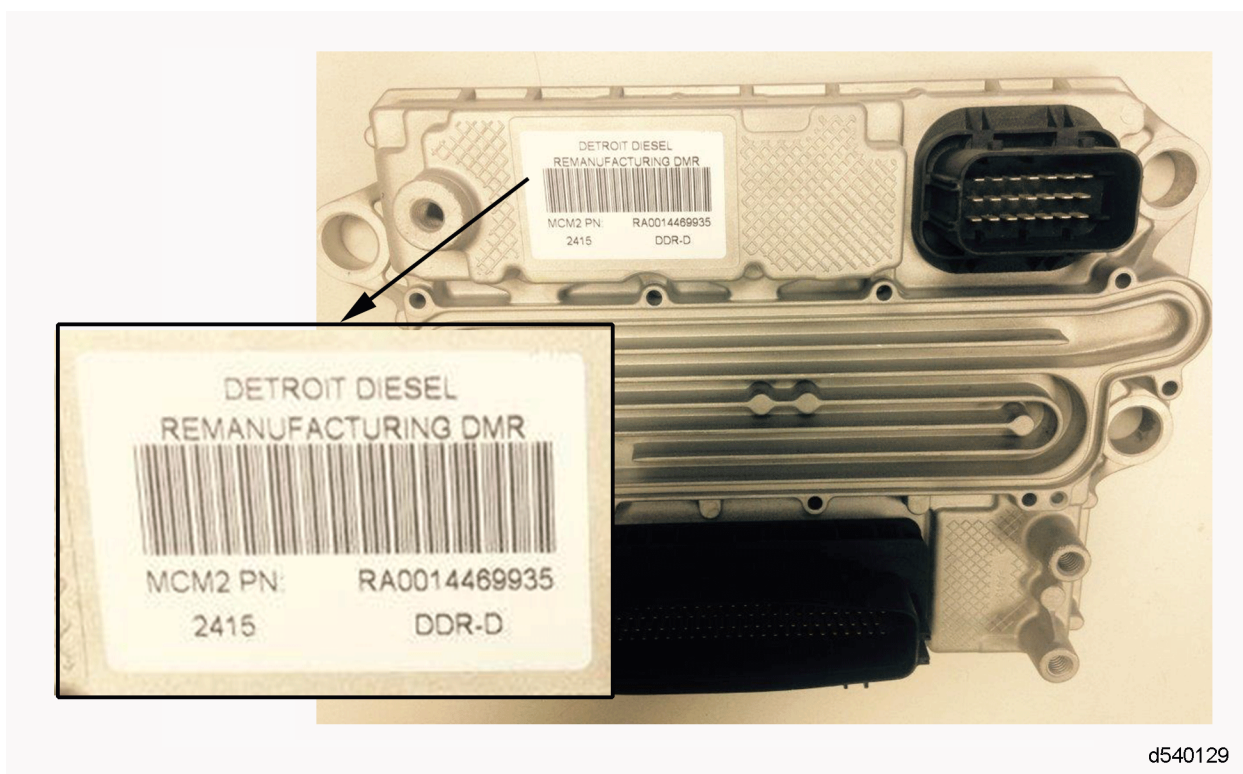

- a. Yes; replace all the copper connector pin injectors on the engine. Verify Repairs.
Refer to section "Removal of the Fuel Injector - Three-Filter System".
Refer to section "Removal of the Fuel Injector - Two-Filter System".
- b. No, replace the MCM with MCM part number RA0014469935. Refer to section "Removal of the Motor Control Module" . Verify repairs. See [15TS-16 \(http://ddcsn-ddc.freightliner.com/cps/rde/xbcr/ddcsn/15TS16.pdf\)](http://ddcsn-ddc.freightliner.com/cps/rde/xbcr/ddcsn/15TS16.pdf) for further information

6 SPN 655/FMI 3 - EPA10

Injector Cylinder #5 Needle Control Valve Abnormal Operation (MAX)

Table 25.

SPN 655/FMI 3	
Description	This code will set when the Needle solenoid current response time does not meet requirement.
Monitored Parameter	Injector Cylinder #5 Needle Control Valve Current
Typical Enabling Conditions	Always enabled
Monitor Sequence	None
Execution Frequency	Continuous
Typical Duration	.02 msec
Dash Lamps	MIL, CEL
Engine Reaction	Derate 25% , EGR Valve shut, DPF Inhibit Regeneration, Limit DEF dosing
Verification	Engine Idle (1 minute)

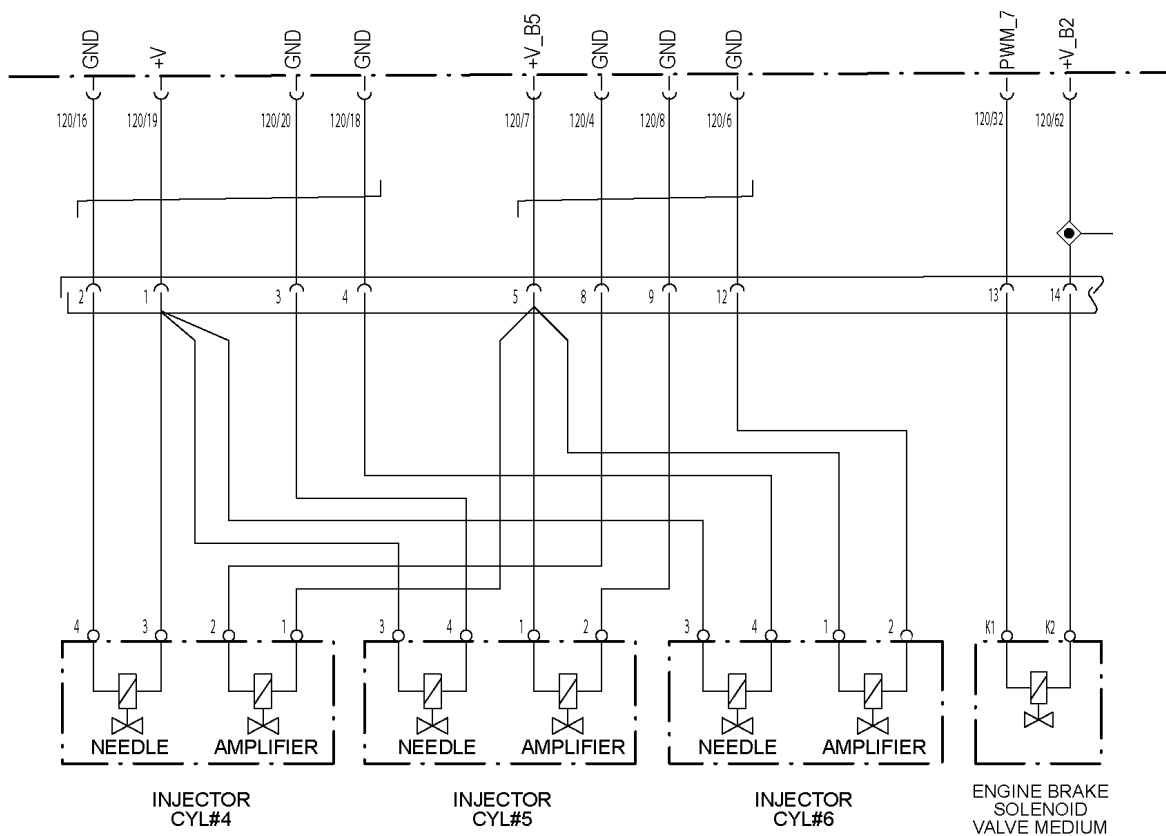

Check as follows:

NOTE: Submit completed diagnostics with warranty claim

NOTE: Injector chart PDF available on DDCSN/SUPPORT/SPECIALIZED SERVICE.

1. Check for multiple codes. Using DiagnosticLink[®], retain log file of active fault and clear codes (code active for one key cycle).
 - a. If SPN fault code 168 or 723/FMI any is present, service those faults first.
 - b. If SPN fault code 168 or 723/FMI any is NOT present, Go to step 2.

**WARNING: ENGINE EXHAUST**

To avoid injury from inhaling engine exhaust, always operate the engine in a well-ventilated area. Engine exhaust is toxic.

**WARNING: PERSONAL INJURY**

To avoid injury before starting and running the engine, ensure the vehicle is parked on a level surface, parking brake is set, and the wheels are blocked.

2. Start and warm the engine until the coolant temperature is above 71°C (160°F).
3. Turn the engine OFF.
4. Disconnect the rear fuel injector harness 14-pin injector connector.
5. Inspect the rear fuel injector harness 14-pin injector connectors for bent or spread pins; inspect the connector seal for damage (signs of water or oil intrusion). Is there any damage found?
 - a. Yes; repair as necessary.
 - b. No; Go to step 6.

NOTE: DO NOT touch the metal ohmmeter leads with your hands when the measurements are made.

6. Using the appropriate chart below, measure and record the resistance values between the corresponding pins on the valve cover side of the rear fuel injector harness listed below. Are the resistances within range?

Table 26.

Rear Fuel Injector Harness 14-Pin Connector Resistance Chart (Valve Cover Side)				
Injector #4 Needle	Pins 1 and 2	Pins 1 and 8	Pin 2 and ground	Pin 8 and ground
	1.3 to 2.5Ω*	Greater than 100kΩ*	Greater than 100kΩ*	Greater than 100kΩ*
	Ω	Ω	Ω	Ω
Injector #5 Needle	Pins 1 and 3	Pins 1 and 9	Pin 3 and ground	Pin 9 and ground
	1.3 to 2.5Ω*	Greater than 100kΩ*	Greater than 100kΩ*	Greater than 100kΩ*
	Ω	Ω	Ω	Ω
Injector #6 Needle	Pins 1 and 4	Pins 1 and 12	Pin 4 and ground	Pin 12 and ground
	1.3 to 2.5Ω*	Greater than 100kΩ*	Greater than 100kΩ*	Greater than 100kΩ*
	Ω	Ω	Ω	Ω
* = acceptable resistance				

VALVE COVER SIDE

d540083

Table 27.

Rear Fuel Injector Harness 14-Pin Connector Resistance Chart (Using J-48671-10 Injector Breakout Box)				
Note: Ensure J-48671-10 ground strap is connected to cylinder head.				
Injector #4 Needle	Pins 3 and 4	Pins 2 and 3	Pin 2 and ground	Pin 3 and ground
	1.3 to 2.5Ω*	Greater than 100kΩ*	Greater than 100kΩ*	Greater than 100kΩ*
	Ω	Ω	Ω	Ω
Injector #5 Needle	Pins 3 and 4	Pins 2 and 3	Pin 2 and ground	Pin 3 and ground
	1.3 to 2.5Ω*	Greater than 100kΩ*	Greater than 100kΩ*	Greater than 100kΩ*
	Ω	Ω	Ω	Ω
Injector #6 Needle	Pins 3 and 4	Pins 2 and 3	Pin 2 and ground	Pin 3 and ground
	1.3 to 2.5Ω*	Greater than 100kΩ*	Greater than 100kΩ*	Greater than 100kΩ*
	Ω	Ω	Ω	Ω
* = acceptable resistance				



- a. Yes; Go to step 12.
 - b. No; Go to step 7.
7. Remove the rocker cover. Refer to section "Removal of the Rocker Cover".
 8. Remove the rear fuel injector harness from the engine.
Refer to section "Removal of the Two-Piece Fuel Injector Wiring Harness - Three-Filter System".
Refer to section "Removal of the Two-Piece Fuel Injector Wiring Harness - Two-Filter System".
- NOTE:** DO NOT touch the metal ohmmeter leads with your hands when the measurements are made.
9. Using the chart below, measure and record the resistance values between the injector pins listed below. Are the resistances within range?

Table 28.

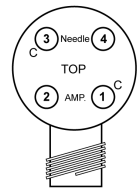

Injector Needle Resistance Chart (Injector Harness must be removed from engine)					
Injector #4 Needle	Pins 3 and 4	Pins 2 and 3	Pin 2 and ground	Pin 3 and ground	
	2.0Ω or less*	Greater than 100kΩ*	Greater than 100kΩ*	Greater than 100kΩ*	
	Ω	Ω	Ω	Ω	
Injector #5 Needle	Pins 3 and 4	Pins 2 and 3	Pin 2 and ground	Pin 3 and ground	
	2.0Ω or less*	Greater than 100kΩ*	Greater than 100kΩ*	Greater than 100kΩ*	
	Ω	Ω	Ω	Ω	
Injector #6 Needle	Pins 3 and 4	Pins 2 and 3	Pin 2 and ground	Pin 3 and ground	
	2.0Ω or less*	Greater than 100kΩ*	Greater than 100kΩ*	Greater than 100kΩ*	
	Ω	Ω	Ω	Ω	
* = acceptable resistance					



d150150

- a. Yes; replace the rear fuel injector harness.
Refer to section "Removal of the Two-Piece Fuel Injector Wiring Harness - Three-Filter System".
Refer to section "Removal of the Two-Piece Fuel Injector Wiring Harness - Two-Filter System".
 - b. No; Go to step 10.
10. Inspect the Injector connector pins and determine whether they are copper or stainless steel. Are all the injectors on the rear bank stainless steel?

Table 29.

 <p style="text-align: center;">d470321</p>	 <p style="text-align: center;">d470322</p>
Stainless Steel Terminals	Copper Alloy Terminals

- a. Yes; replace the injector with the out-of-range resistance.
Refer to section "Removal of the Fuel Injector - Three-Filter System".
Refer to section "Removal of the Fuel Injector - Two-Filter System".
 - b. No; Go to step 11.
11. Review the MCM Hardware Part Number on the sticker located on the front of the MCM, shown in the figure below. Is the MCM Hardware part number RA0014469935 or RA0024460135?

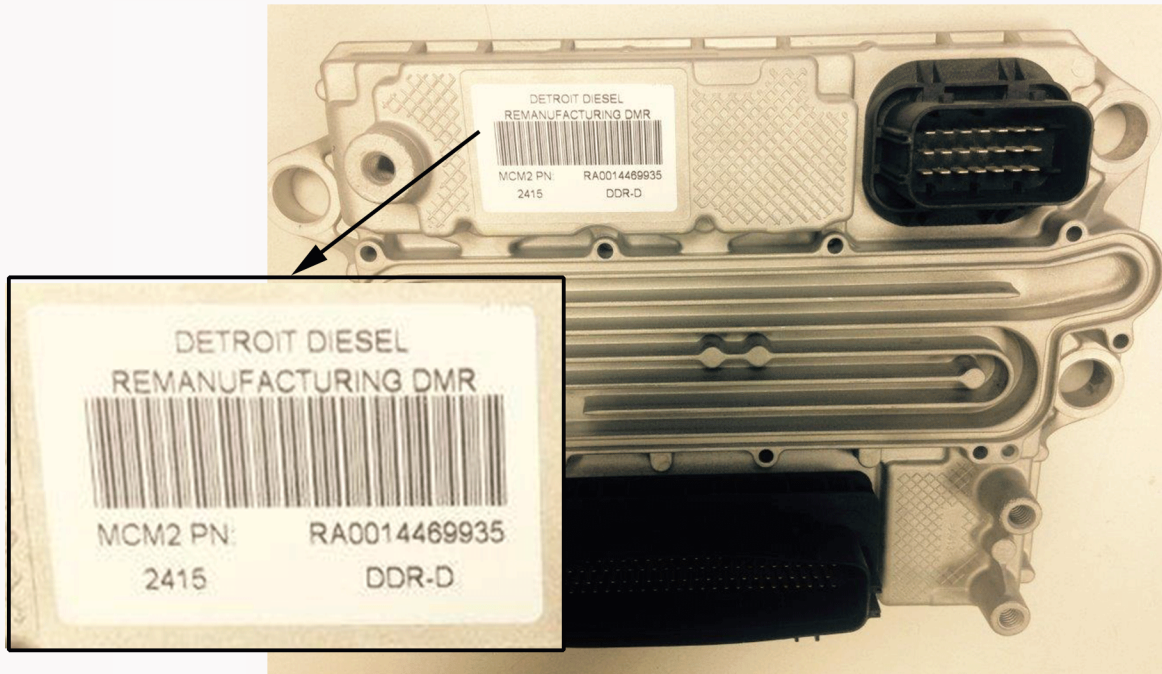

d540129

- a. Yes; replace all the copper connector pin injectors on the engine. Verify repairs.
Refer to section "Removal of the Fuel Injector - Three-Filter System".
Refer to section "Removal of the Fuel Injector - Two-Filter System".
 - b. No; replace the MCM with MCM part number RA0014469935. Refer to section "Removal of the Motor Control Module". Verify repairs. See [15TS-16](http://ddcsn-ddc.freightliner.com/cps/rde/xbcr/ddcsn/15TS16.pdf) (<http://ddcsn-ddc.freightliner.com/cps/rde/xbcr/ddcsn/15TS16.pdf>) for further information.
12. Disconnect the Motor Control Module (MCM) 120-pin connector.
 13. Inspect the MCM 120-pin connector and 120-pin harness connector for signs of corrosion, spread, unseated (pushed out) or damaged pins, connector seal for damage (signs of water or oil intrusion) or signs of wire damage.
 - a. If signs of damage are found, repair as necessary. Verify repairs.
 - b. If no signs of damage, Go to step 14.

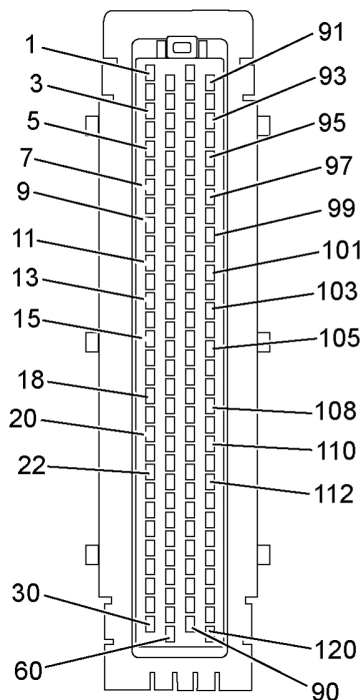

ENGINE HARNESS SIDE

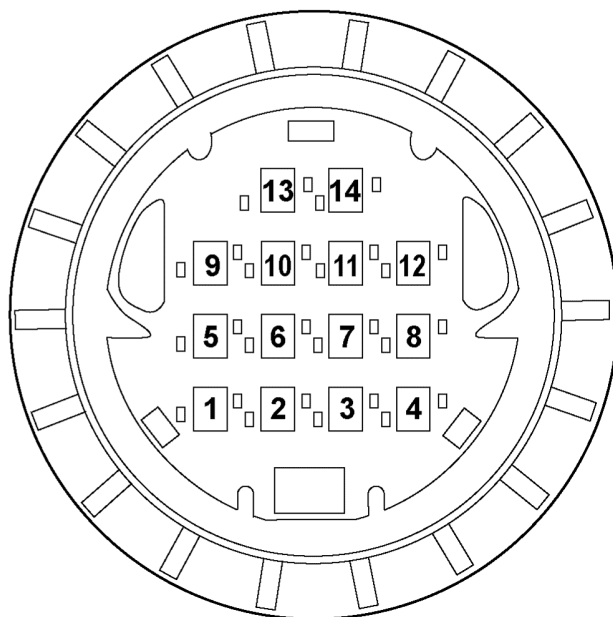

d540080

NOTE: DO NOT touch the metal ohmmeter leads with your hands when the measurements are made.

14. Using the chart below, measure and record the resistance values between the engine side of the front valve cover 14-pin connector and the MCM 120-pin connector. Are the resistances within range?

Table 30.

Engine Harness Injector Circuit Resistance Table				
Rear Engine Side Valve Cover 14-pin connector #	MCM 120-Pin Harness Connector	Acceptable Resistance 1Ω or less	Rear Engine Side Valve Cover 14 pin connector #	Acceptable Resistance 1KΩ or greater
1	19	Ω	1 and ground	Ω
2	16	Ω	2 and ground	Ω
3	20	Ω	3 and ground	Ω
4	18	Ω	4 and ground	Ω

- a. Yes; Go to step 15.
 - b. No; repair the engine side harness. Verify repairs.
15. Review the MCM Hardware Part Number on the sticker located on the front of the MCM, under the Instrumentation window in DiagnosticLink as shown in the figure below. Is the MCM Hardware part number RA0014469935 or RA0024460135?

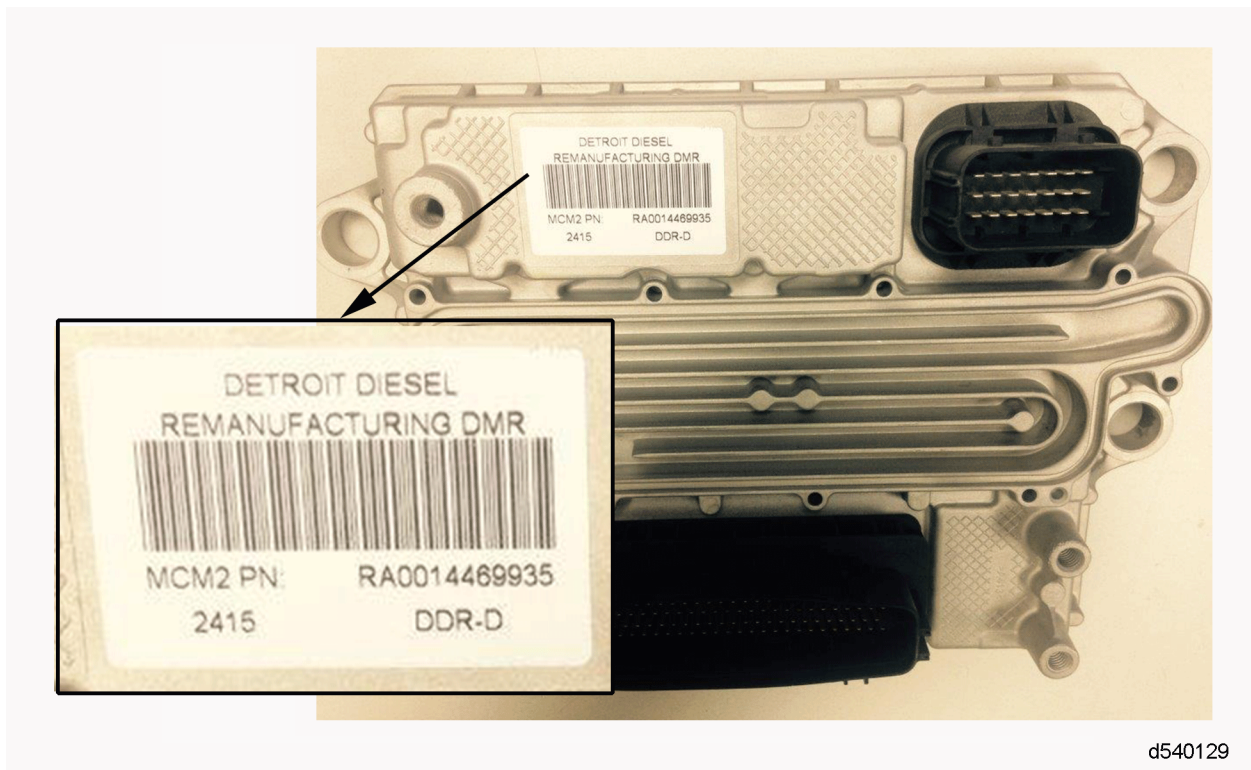

- a. Yes; replace all the copper connector pin injectors on the engine. Verify repairs.
Refer to section "Removal of the Fuel Injector - Three-Filter System".
Refer to section "Removal of the Fuel Injector - Two-Filter System".
- b. No; replace the MCM with MCM part number RA0014469935. Refer to section "Removal of the Motor Control Module" . Verify repairs. See [15TS-16 \(http://ddcsn-ddc.freightliner.com/cps/rde/xbcr/ddcsn/15TS16.pdf\)](http://ddcsn-ddc.freightliner.com/cps/rde/xbcr/ddcsn/15TS16.pdf) for further information.

7 SPN 656/FMI 3 - EPA10

Injector Cylinder #6 Needle Control Valve Abnormal Operation (MAX)

Table 31.

SPN 656/FMI 3	
Description	This code will set when the Needle solenoid current response time does not meet requirement.
Monitored Parameter	Injector Cylinder #6 Needle Control Valve Current
Typical Enabling Conditions	Always enabled
Monitor Sequence	None
Execution Frequency	Continuous
Typical Duration	.02 msec
Dash Lamps	MIL, CEL
Engine Reaction	Derate 25%, EGR Valve shut, DPF Inhibit Regeneration, Limit DEF dosing
Verification	Engine Idle (1 minute)

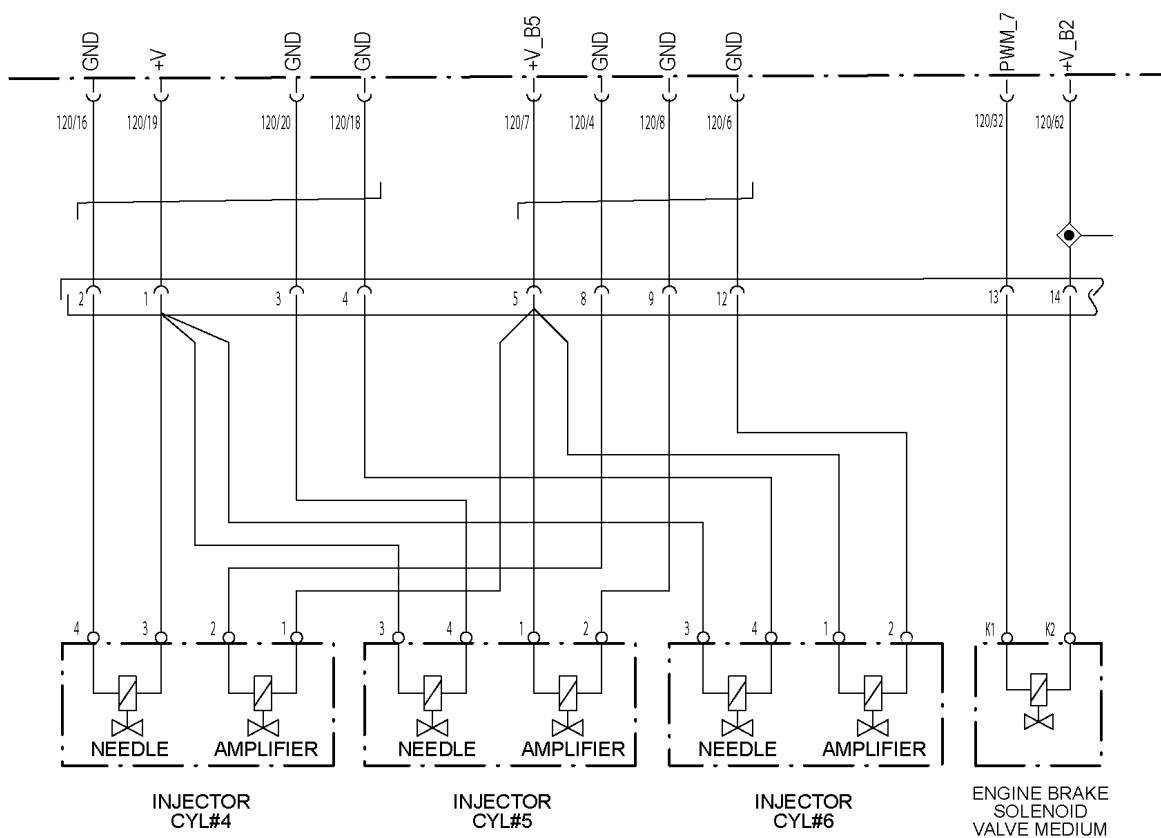

d150022

Check as follows:

NOTE: Submit completed diagnostics with warranty claim.

NOTE: Injector chart PDF available on DDCSN/SUPPORT/SPECIALIZED SERVICE.

1. Check for multiple codes. Using DiagnosticLink[®], retain log file of active fault and clear codes (code active for one key cycle).
 - a. If SPN fault code 168 or 723/FMI any is present, service those faults first.
 - b. If SPN fault code 168 or 723/FMI any is NOT present, Go to step 2.



WARNING: ENGINE EXHAUST

To avoid injury from inhaling engine exhaust, always operate the engine in a well-ventilated area. Engine exhaust is toxic.



WARNING: PERSONAL INJURY

To avoid injury before starting and running the engine, ensure the vehicle is parked on a level surface, parking brake is set, and the wheels are blocked.

2. Start and warm the engine until the coolant temperature is above 71°C (160°F).
3. Turn the engine OFF.
4. Disconnect the rear fuel injector harness 14-pin injector connector.
5. Inspect the rear fuel injector harness 14-pin injector connectors for bent or spread pins; inspect the connector seal for damage (signs of water or oil intrusion). Is there any damage found?
 - a. Yes; repair as necessary.
 - b. No; Go to step 6.

NOTE: DO NOT touch the metal ohmmeter leads with your hands when the measurements are made.

6. Using the appropriate chart below, measure and record the resistance values between the corresponding pins on the valve cover side of the rear fuel injector harness listed below. Are the resistances within range?

Table 32.

Rear Fuel Injector Harness 14-Pin Connector Resistance Chart (Valve Cover Side)				
Injector #4 Needle	Pins 1 and 2	Pins 1 and 8	Pin 2 and ground	Pin 8 and ground
	1.3 to 2.5Ω*	Greater than 100kΩ*	Greater than 100kΩ*	Greater than 100kΩ*
	Ω	Ω	Ω	Ω
Injector #5 Needle	Pins 1 and 3	Pins 1 and 9	Pin 3 and ground	Pin 9 and ground
	1.3 to 2.5Ω*	Greater than 100kΩ*	Greater than 100kΩ*	Greater than 100kΩ*
	Ω	Ω	Ω	Ω
Injector #6 Needle	Pins 1 and 4	Pins 1 and 12	Pin 4 and ground	Pin 12 and ground
	1.3 to 2.5Ω*	Greater than 100kΩ*	Greater than 100kΩ*	Greater than 100kΩ*
	Ω	Ω	Ω	Ω
* = acceptable resistance				

VALVE COVER SIDE

d540083

Table 33.

Rear Fuel Injector Harness 14-Pin Connector Resistance Chart (Using J-48671-10 Injector Breakout Box)				
Note: Ensure J-48671-10 ground strap is connected to cylinder head.				
Injector #4 Needle	Pins 3 and 4	Pins 2 and 3	Pin 2 and ground	Pin 3 and ground
	1.3 to 2.5Ω*	Greater than 100kΩ*	Greater than 100kΩ*	Greater than 100kΩ*
	Ω	Ω	Ω	Ω
Injector #5 Needle	Pins 3 and 4	Pins 2 and 3	Pin 2 and ground	Pin 3 and ground
	1.3 to 2.5Ω*	Greater than 100kΩ*	Greater than 100kΩ*	Greater than 100kΩ*
	Ω	Ω	Ω	Ω
Injector #6 Needle	Pins 3 and 4	Pins 2 and 3	Pin 2 and ground	Pin 3 and ground
	1.3 to 2.5Ω*	Greater than 100kΩ*	Greater than 100kΩ*	Greater than 100kΩ*
	Ω	Ω	Ω	Ω
* = acceptable resistance				

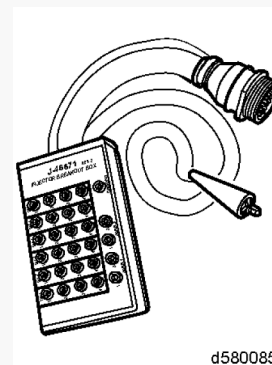

- a. Yes; Go to step 12.
- b. No; Go to step 7.

7. Remove the rocker cover. Refer to section "Removal of the Rocker Cover".
8. Remove the rear fuel injector harness from the engine.
Refer to section "Removal of the Two-Piece Fuel Injector Wiring Harness - Three-Filter System".
Refer to section "Removal of the Two-Piece Fuel Injector Wiring Harness - Two-Filter System".

NOTE: DO NOT touch the metal ohmmeter leads with your hands when the measurements are made.

9. Using the chart below, measure and record the resistance values between the injector pins listed below. Are the resistances within range?

Table 34.

Injector Needle Resistance Chart (Injector Harness must be removed from engine)					
Injector #4 Needle	Pins 3 and 4	Pins 2 and 3	Pin 2 and ground	Pin 3 and ground	
	2.0Ω or less*	Greater than 100kΩ*	Greater than 100kΩ*	Greater than 100kΩ*	
	Ω	Ω	Ω	Ω	
Injector #5 Needle	Pins 3 and 4	Pins 2 and 3	Pin 2 and ground	Pin 3 and ground	
	2.0Ω or less*	Greater than 100kΩ*	Greater than 100kΩ*	Greater than 100kΩ*	
	Ω	Ω	Ω	Ω	
Injector #6 Needle	Pins 3 and 4	Pins 2 and 3	Pin 2 and ground	Pin 3 and ground	
	2.0Ω or less*	Greater than 100kΩ*	Greater than 100kΩ*	Greater than 100kΩ*	
	Ω	Ω	Ω	Ω	
* = acceptable resistance					

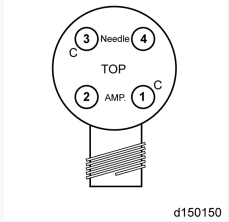

- a. Yes; replace the rear fuel injector harness.
Refer to section "Removal of the Two-Piece Fuel Injector Wiring Harness - Three-Filter System".
Refer to section "Removal of the Two-Piece Fuel Injector Wiring Harness - Two-Filter System".
 - b. No; Go to step 10.
10. Inspect the Injector connector pins and determine whether they are copper or stainless steel. Are all the injectors on the rear bank stainless steel?

Table 35.

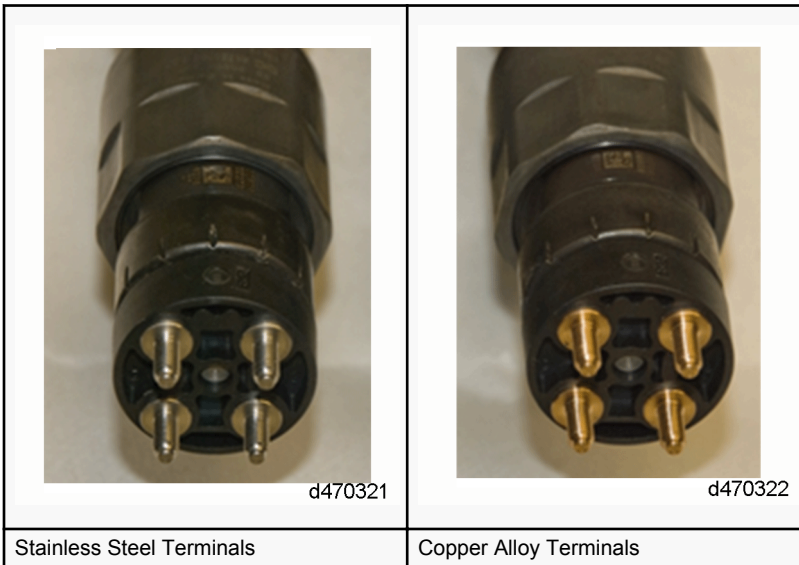

- a. Yes; replace the injector with the out-of-range resistance.
Refer to section "Removal of the Fuel Injector - Three-Filter System".
Refer to section "Removal of the Fuel Injector - Two-Filter System".
 - b. No; Go to step 11.
11. Review the MCM Hardware Part Number on the sticker located on the front of the MCM, shown in the figure below. Is the MCM Hardware part number RA0014469935 or RA0024460135?



d540129

- a. Yes; replace all the copper connector pin injectors on the engine. Verify repairs.
Refer to section "Removal of the Fuel Injector - Three-Filter System".
Refer to section "Removal of the Fuel Injector - Two-Filter System".
 - b. No; replace the MCM with MCM part number RA0014469935. Refer to section "Removal of the Motor Control Module". Verify repairs. See [15TS-16](http://ddcsn-ddc.freightliner.com/cps/rde/xbcr/ddcsn/15TS16.pdf) (<http://ddcsn-ddc.freightliner.com/cps/rde/xbcr/ddcsn/15TS16.pdf>) for further information.
12. Disconnect the Motor Control Module (MCM) 120-pin connector.
 13. Inspect the MCM 120-pin connector and 120-pin harness connector for signs of corrosion, spread, unseated (pushed out) or damaged pins, connector seal for damage (signs of water or oil intrusion) or signs of wire damage.
 - a. If signs of damage are found, repair as necessary. Verify repairs.
 - b. If no signs of damage, Go to step 14.

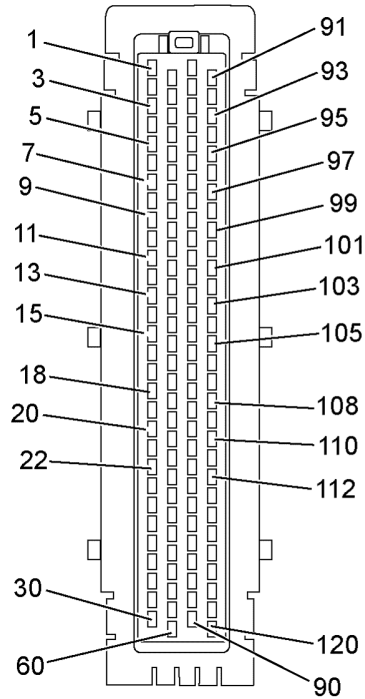

ENGINE HARNESS SIDE

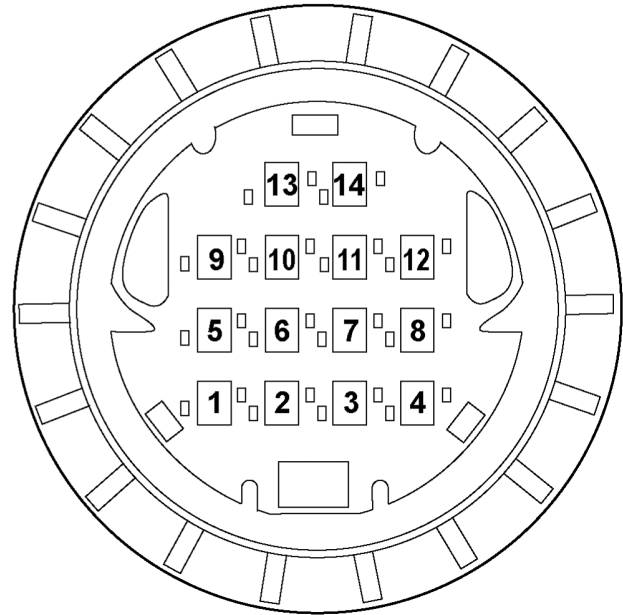

d540080

NOTE: DO NOT touch the metal ohmmeter leads with your hands when the measurements are made.

14. Using the chart below, measure and record the resistance values between the engine side of the front valve cover 14-pin connector and the MCM 120-pin connector. Are the resistances within range?

Table 36.

Engine Harness Injector Circuit Resistance Table				
Rear Engine Side Valve Cover 14-pin connector #	MCM 120-Pin Harness Connector	Acceptable Resistance 1Ω or less	Rear Engine Side Valve Cover 14 pin connector #	Acceptable Resistance 1KΩ or greater
1	19	Ω	1 and ground	Ω
2	16	Ω	2 and ground	Ω
3	20	Ω	3 and ground	Ω
4	18	Ω	4 and ground	Ω

- a. Yes; Go to step 15.
 - b. No; repair the engine side harness. Verify repairs.
15. Review the MCM Hardware Part Number on the sticker located on the front of the MCM, under the Instrumentation window in DiagnosticLink as shown in the figure below. Is the MCM Hardware part number RA0014469935 or RA0024460135?

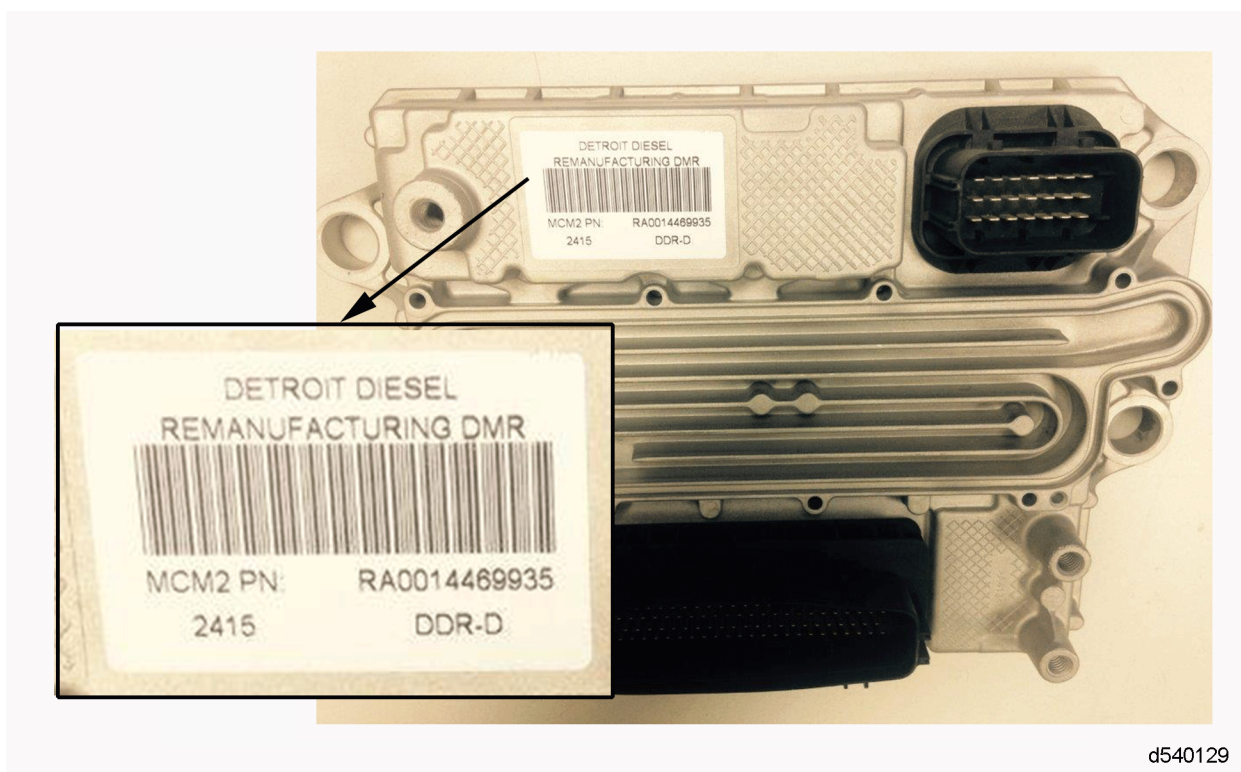

- a. Yes; replace all the copper connector pin injectors on the engine. Verify repairs.
Refer to section "Removal of the Fuel Injector - Three-Filter System".
Refer to section "Removal of the Fuel Injector - Two-Filter System".
- b. No; replace the MCM with MCM part number RA0014469935. Refer to section "Removal of the Motor Control Module". Verify repairs. See [15TS-16](http://ddcsn-ddc.freightliner.com/cps/rde/xbcr/ddcsn/15TS16.pdf) (<http://ddcsn-ddc.freightliner.com/cps/rde/xbcr/ddcsn/15TS16.pdf>) for further information.