

This Service Bulletin replaces Service Bulletin, "Cab Climate Unit, Design and Function" (11.2002), publication number PV776-TSP174409.

Date	Group	No.	Page
4.2004	874	21	1(25)

Cab Climate Unit
Specifications, Design and Function
CU-BAS, CU-MCC, CU-ECC
VN, VHD VERSION2

Cab Climate Unit, Specifications, Design and Function

This service bulletin describes the specifications and design and function of the climate unit.

Contents:

- "Climate Unit" page 2
- "Specifications" page 3
- "Pressure monitor switch points" page 3
- "General" page 4
- "Air Distribution" page 5
- "Structure" page 6
- "Controls" page 14
- "Heater" page 15
- "A/C System Components" page 17

Climate Unit

There are three versions of the climate unit, two of which are air conditioning units (that is, combined hot and cold air units):

- Heat "CU-BAS"
- Manual air conditioning "CU-MCC"
- Automatic air conditioning "CU-ECC"

The units are combined in this manual since the differences between the units are only the components that affect air conditioning.

Climate Control System

Specifications

Refrigerant, type	R134a (Tetrafluoroethane)
Air conditioning, volume	1400 g (3.09 lb.) - VNM, VNL, VHD 1600 g (3.53 lb.) - VN 430, 630 1700 g (3.75 lb.) - VN 670, 780
Compressor, marking	SD 7H15
No. of cylinders	7
Cylinder volume	155 cm ³ (9.46 in. ³)
Compressor coupling	Electromagnetic
Lubricating oil capacity	300 cc (18.30 in. ³)

Pressure monitor switch points

High pressure

opens at	28 ± 2 (406 PSI)
closes at	22 ± 2 (319 PSI)

Low pressure

opens at	2.0 ± 0.2 (29 PSI)
closes at	2.1 ± 0.2 (30 PSI)

Climate Control System Overview

General

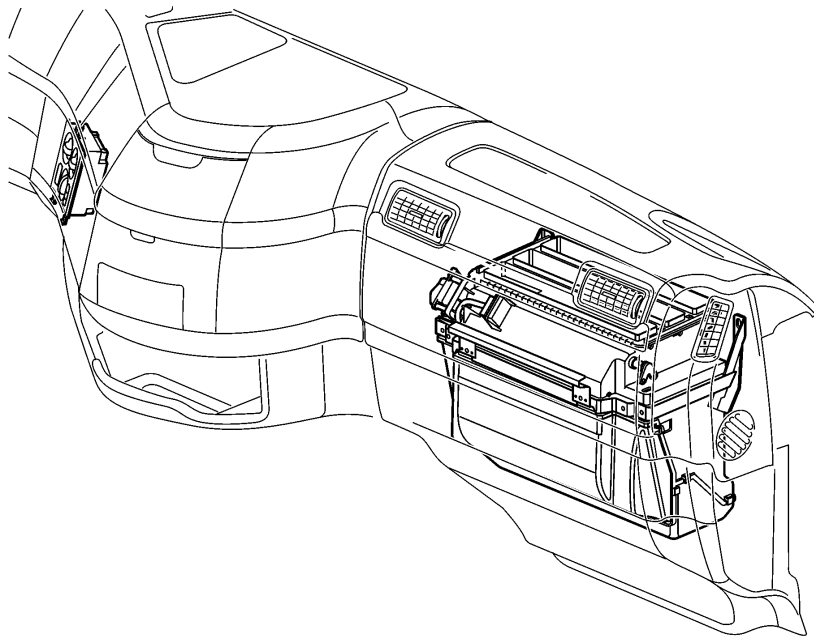

T8009771

VN vehicle

The air inlet at the front of the cab has a replaceable filter to clean the air which flows in through the air inlet. The filter must be replaced regularly, see the service manual, function group 87. The air that comes in via the air conditioning unit is distributed around the cab. The air is distributed so that surfaces that may be subject to cold convection are heated up.

The air leaves the cab through the evacuation vents in the doors and the C-pillars at the rear of the cab. The incoming air sweeps round the windshield, up to the roof, down the rear wall to the floor and up between the door trim and outer panels to pass out through the openings at the rear of the cab. This ventilation system eliminates cold convection from the rear wall, which is particularly important in cabs used as sleeping cabs. The non-return valves in the air extraction vents prevent the air from going the wrong way through the air vents and are dimensioned to ensure that a small excess pressure is formed inside the cab, to prevent drafts from outside.

The output of the heating system is such that the cab temperature can be maintained at 45°C (113°F) when the outside temperature is -20°C (-4°F).

Air Distribution

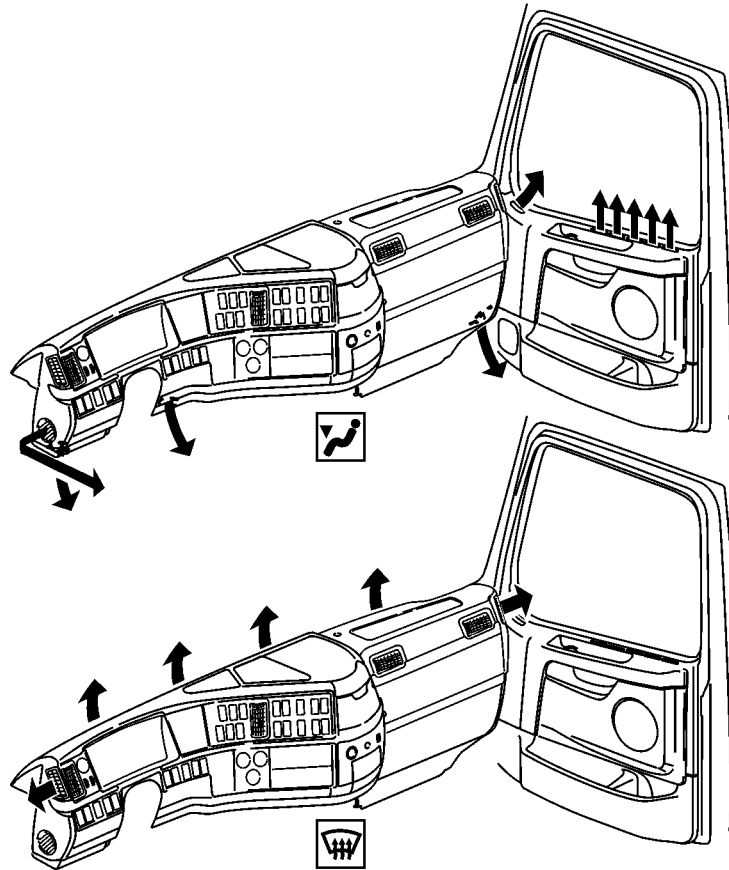

T8009776

The dashboard is equipped with 4 nozzles which can be aimed individually or closed completely. 2 nozzles on either side of the dashboard direct air to the driver's and passenger's feet and knees. The same ducts also direct air up into the doors, through the doors and up through 6 nozzles to the side windows. The defroster, 4 nozzles underneath the windshield and one on each side of the dashboard, directs air onto the windows.

There is an air inlet in the center of the dashboard, where the temperature sensor for cabin air is located. The sensor also contains a suction fan to read off the current temperature.

Structure

External Cooling Components

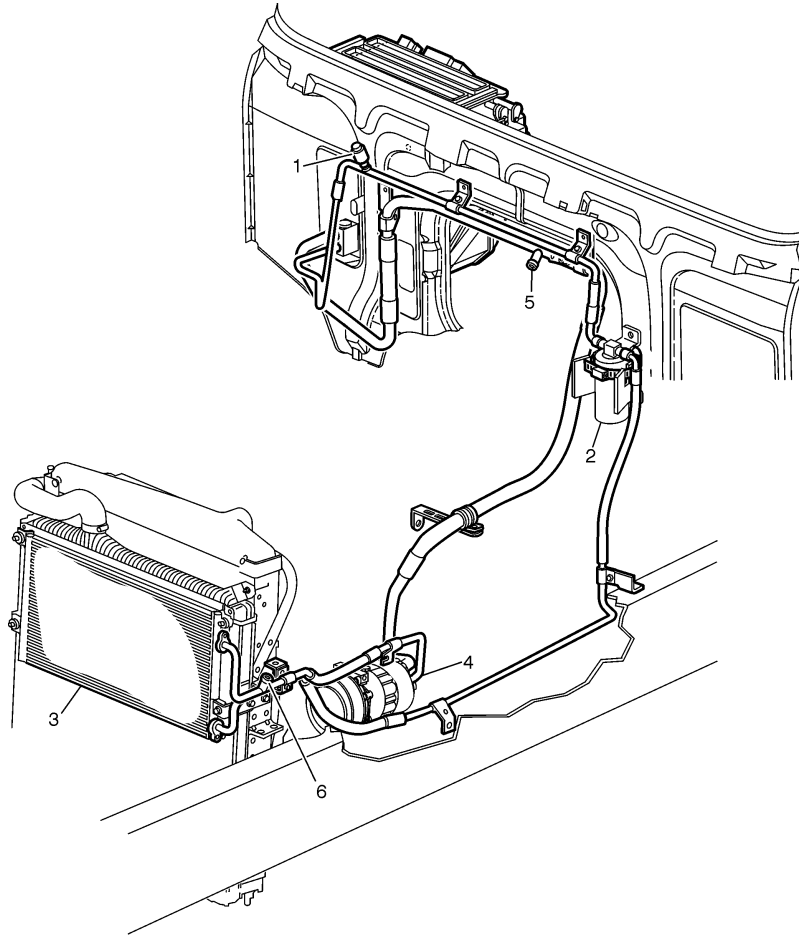

W8003236

- 1 High-low pressure monitor
- 2 Drier, refrigerant reservoir
- 3 Condenser
- 4 Compressor
- 5 Low pressure charge port
- 6 High pressure charge port

- 1 The pressure monitor is in the delivery line (fluid under high pressure) before the expansion valve in the climate unit. The purpose of the high-low pressure monitor is to signal to the control unit to interrupt the current to the compressor if abnormal pressure should occur.
- 2 In the drier, any moisture is absorbed and any particles which might be found in the fluid are filtered out. The outlet side of the drier is connected to a pipe which goes to the base of the drier. Since the fluid level is higher than the lower end of the pipe, the refrigerant is prevented from leaving the drier in vapour form.
- 3 The purpose of the condenser is to cool the refrigerant. The superheated refrigerant gas is cooled to condensation by ambient air flow across the condenser fins.

- 4 The compressor is the working component in the air conditioning (A/C) unit. It works as a pump in the system, since it draws up the evaporated refrigerant from the evaporator and forces it into the condenser.
- 5 The low pressure charge port is used for filling and draining the system.
- 6 The high pressure charge port is used for filling and draining the system.

Structure

BAS

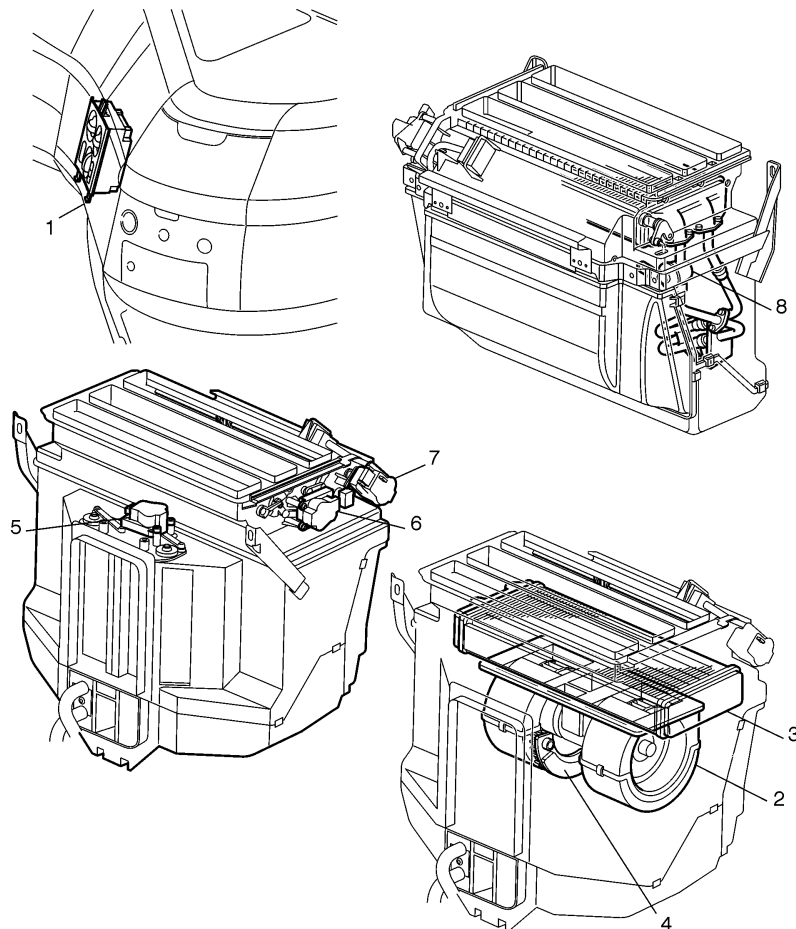

T8008645

- 1 Control Unit/control panel
- 2 Blower motor
- 3 Heater core
- 4 Fan speed controller
- 5 Stepper motor, fresh air/recirculation
- 6 Stepper motor, air distribution
- 7 Stepper motor heat control
- 8 Water valve

- 1 The control unit controls the system components depending on the values set in the control panel.
- 2 The blower motor draws air in through the filter in the bulkhead and on through the evaporator or heater core. The over pressure created by the fan combined with the evacuation holes in the cab provides even air flow distribution.
- 3 The purpose of the heater core is to heat the air entering the cab. The coolant heated by the engine flows through the heater core pipes and heats the cooling fins. If the hot coolant does not flow through the heater core, it is cooled down and will not generate any heat.

- 4 The fan speed controller regulates the cabin air. The fan control is constantly supplied with 12 V and controlled by a variable voltage of 0–6 V.
- 5 The stepper motor controls the shutter for fresh air/recirculation.
- 6 The stepper motor controls the shutter for directing the outlet air.
- 7 The stepper motor controls the water flow water valve.
- 8 The water valve opens and closes the flow of coolant through the heater core.

Structure

MCC

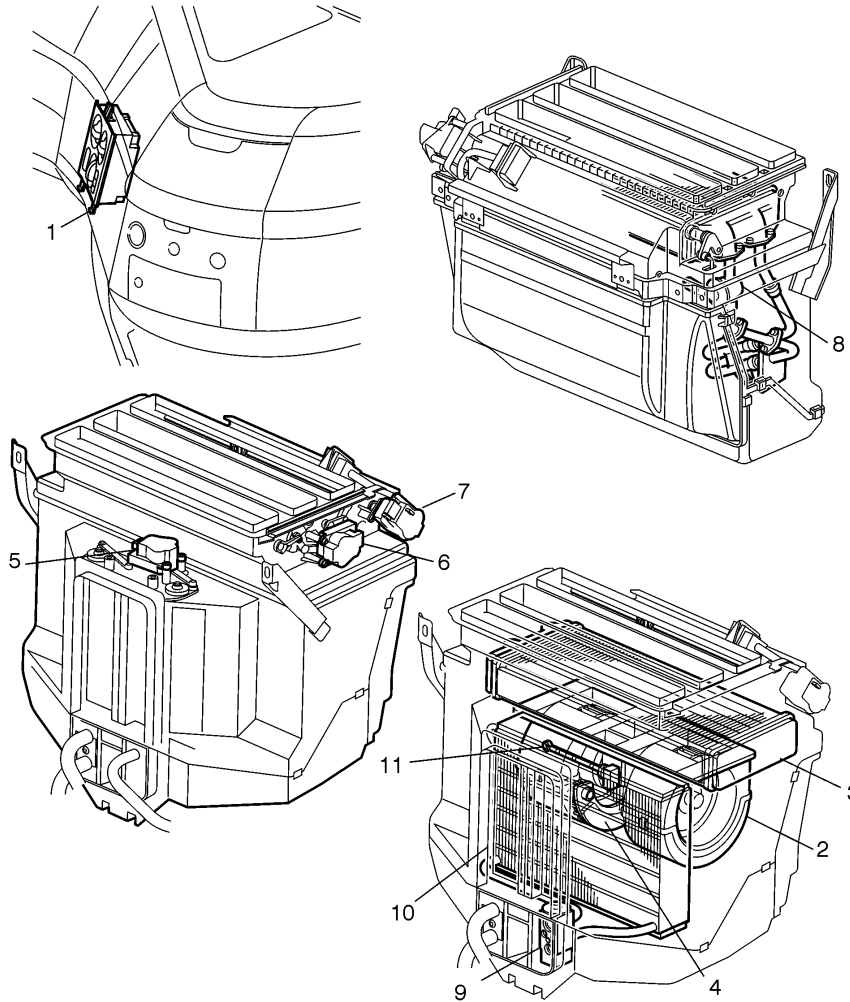

- 1 Control Unit/control panel
- 2 Blower motor
- 3 Heater core
- 4 Fan speed controller
- 5 Stepper motor, fresh air/recirculation
- 6 Stepper motor, air distribution
- 7 Stepper motor heat control
- 8 Water valve
- 9 Expansion valve
- 10 Evaporator
- 11 Temperature sensor

T8008646

- 1 The control unit controls the system components depending on the values set on the control panel and the values from the sensor.
- 2 The blower motor draws air in through the filter in the bulkhead and on through the evaporator or heater core. The over pressure created by the fan combined with the evacuation holes in the cab provides even air flow distribution.
- 3 The purpose of the heater core is to heat the air entering the cab. The coolant heated by the engine flows through the heater core pipes and heats the cooling fins. If hot coolant does not flow through the heater core, it cools down shortly afterwards and will not generate any heat.
- 4 The fan speed controller regulates the cabin air. The fan control is constantly supplied with 12 V and controlled by a variable voltage of 0–6 V.
- 5 The stepper motor controls the shutter for fresh air/recirculation.
- 6 The stepper motor controls the shutters for directing the outlet air.
- 7 The stepper motor controls shutter for the water flow water valve.
- 8 The water valve opens and closes the flow of coolant through the heater core.
- 9 The purpose of the expansion valve is to regulate the flow of liquid refrigerant to the evaporator and provide a drop in pressure so that the refrigerant will easily absorb heat from the evaporator. The valve is an internally equalized expansion valve that compares the evaporator inlet pressure to the evaporator outlet pressure. This allows for a refrigerant flow consistent with the amount of heat that needs to be absorbed and to keep the evaporator from flooding (a flooded evaporator is highly inefficient and results in very little cooling).
- 10 The evaporator is the heat exchanger that allows the heat of the cab air to be absorbed by the R134a refrigerant. It is located inside the climate control unit so that cab air circulated by the blower passes through it. The evaporator is constructed of stacked plates that are surrounded by fins. The heat of the cab air passing through the fins is transferred to the fins and the plates. The refrigerant is metered into the evaporator through the expansion valve and travels through the plates of the evaporator. As the evaporator collects heat from the cab the heat is transferred to the refrigerant which boils to a vapor.
- 11 The MCC unit cuts off the compressor at 3°C (37°F) and goes back on at 8°C (46°F). The temperature will change to the coldest if the control nob is on maximum cold. The control unit itself cuts voltage to the compressor and not the sensor.

Structure

ECC

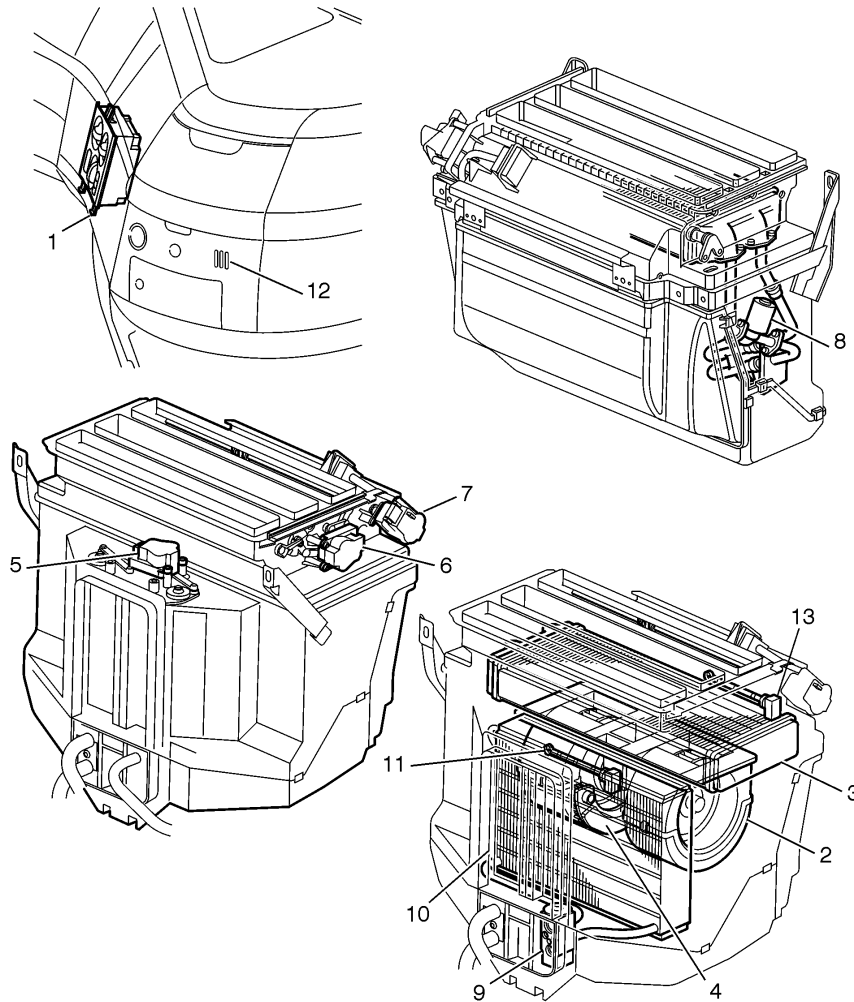

- 1 Control Unit/control panel
- 2 Blower motor
- 3 Heater core
- 4 Fan speed controller
- 5 Stepper motor, fresh air/recirculation
- 6 Stepper motor, air distribution
- 7 Stepper motor, air bypass
- 8 Solenoid water valve
- 9 Expansion valve
- 10 Evaporator
- 11 Temperature sensor, evaporator
- 12 Temperature sensor, cabin temperature
- 13 Temperature sensor, heater core

T8009810

- 1 The control unit controls the system components depending on the values set on the control panel and the values from the sensor. This is so that a pleasant climate can be maintained in the cab.
- 2 The blower motor draws air in through the filter in the bulkhead and on through the evaporator or heater core. The over pressure created by the fan combined with the evacuation holes in the cab provides even air flow distribution.
- 3 The purpose of the heater core is to heat the air entering the cab. The coolant heated by the engine flows through the heater core ducts and heats the cooling fans. If hot coolant does not flow through the heater core, it cools down shortly afterwards and will not generate any heat.
- 4 The fan speed controller regulates the cabin air. The fan control is constantly supplied with 12 V and controlled by a variable voltage of 0–6 V.
- 5 The stepper motor controls the shutter for fresh air/recirculation.
- 6 The stepper motor controls the shutters for directing the outlet air.
- 7 The stepper motor controls the shutter for air bypass.
- 8 The solenoid water valve opens and closes the flow of coolant through the heater core.
- 9 The purpose of the expansion valve is to regulate the flow of liquid refrigerant to the evaporator and provide a drop in pressure so that the refrigerant will easily absorb heat from the evaporator. The valve is an internally equalized expansion valve that compares the evaporator inlet pressure to the evaporator outlet pressure. This allows for a refrigerant flow consistent with the amount of heat that needs to be absorbed and to keep the evaporator from flooding (a flooded evaporator is highly inefficient and results in very little cooling).
- 10 The evaporator is the heat exchanger that allows the heat of the cab air to be absorbed by the R134a refrigerant. It is located inside the climate control unit so that cab air circulated by the blower passes through it. The evaporator is constructed of stacked plates that is surrounded by fins. The heat of the cab air passing through the fins is transferred to the fins and the plates. The refrigerant is metered into the evaporator through the expansion valve and travels through the plates of the evaporator. As the evaporator collects heat from the cab the heat is transferred to the refrigerant which boils to a vapor.
- 11 Only in max – cold, the ECC unit cuts off the compressor at 3°C (37°F) and goes back on at 8°C (46°F). The temperature will change to the coldest if the control knob is on maximum cold. The control unit itself cuts voltage to the compressor and not the sensor.
- 12 The cab temperature transmits signals to the control unit about the current temperature so that it can control the system to maintain a predetermined temperature in the cab. The temperature sensor fan draws air into the cab so that the sensor retains the current cab temperature.

Controls

BAS

All the controls are located in a panel in the center of the dashboard.

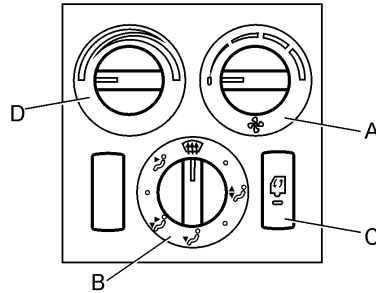

T8008629

A Fan

- Position 0
- Position 1
- Position 2
- Position 3
- Position 4

C Fresh Air

Fresh air inlet fully open



B Air Distribution

Defroster only



Fresh air inlet closed, only recirculation



Defroster and lower ventilation nozzle



D Temperature

The control has stepless adjustment. The heat is shut off when the control is furthest left (blue). As the control is moved to the right (red), the heat is increased.

Mainly lower ventilation nozzle and some defrost



Upper and lower ventilation nozzles



Only upper ventilation nozzles



Can be constructed of both settings

Controls

MCC

All the controls are located in a panel in the center of the dashboard.

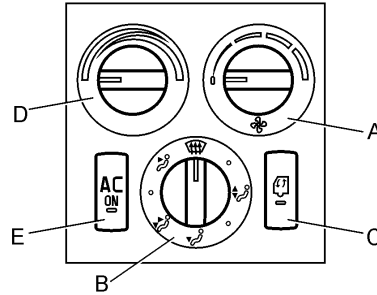

T8008630

A Fan

- Position 0
- Position 1
- Position 2
- Position 3
- Position 4

C Fresh Air

Fresh air inlet fully open



B Air Distribution

Defroster only



Fresh air inlet closed, only recirculation



Defroster and lower ventilation nozzle



D Temperature

The control has stepless adjustment. The heat is shut off when the control is furthest left (blue). As the control is moved to the right (red), the heat is increased.

Mainly lower ventilation nozzle and some defrost



E Air Conditioning

The "A/C on" button should be depressed (green light on) when the air conditioning compressor operation is required to reach the desired cab temperature.

Upper and lower ventilation nozzles



Only upper ventilation nozzles



Can be constructed of both settings

Controls

ECC

All the controls are located in a panel in the center of the dashboard.

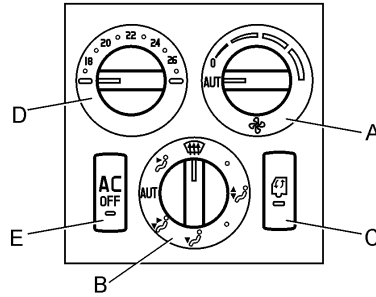

T8008631

A Fan

“AUT” position: The system automatically controls the fan speed.

- Position 0
- Position 1
- Position 2
- Position 3
- Position 4

C Fresh Air

Fresh air inlet fully open



Fresh air inlet closed, only recirculation



B Air Distribution

“AUT” position automatic control. Defroster only



Defroster and lower ventilation nozzle



Mainly lower ventilation vent and some defrost



Upper and lower ventilation nozzles



Only upper ventilation nozzles



Can be constructed of both settings

D Temperature

Blue is maximum cold and red maximum hot. Anything in between is temperature sensor reading.

E Air Conditioning

The “A/C off” button should be depressed (amber light on) when the air conditioning compressor cycling is not desired. When depressed, the control unit will still try and maintain the set temperature by combining air into the climate unit, with varying heat from the heater core.

Heater

A/C System Components

Heater Core

The purpose of the heater core is to heat the air coming into the cab. The heater core is connected to the cooling system of the engine, and is located in the upper section of the air conditioning unit.

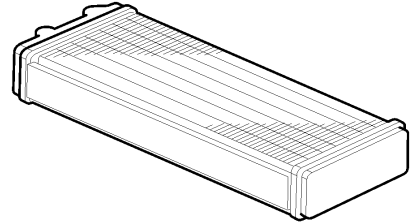

T8008642

Fan Motor

The purpose of the fan motor is to force the cabin air through the climate unit. The temperature sensor is mounted in the fan motor.

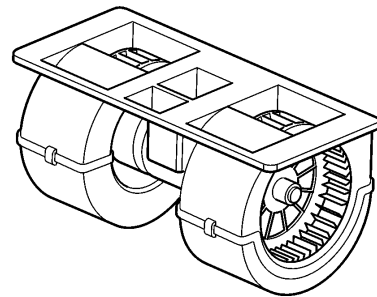

T8008639

Fan Speed Controller

The fan speed controller regulates the cabin air. The fan control is constantly supplied with 12 V and controlled by a variable voltage of 0–6 V.

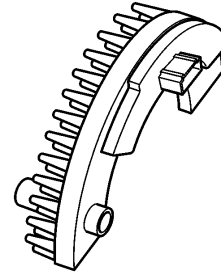

T8008638

Solenoid Water Valve

The solenoid water valve opens and closes the water flowing through the heater core in the air conditioning unit. Control is by means of electrical impulses from the control unit. The solenoid water valve is only found on vehicles with automatic air conditioning “CU-ECC”. The solenoid water valve is constantly supplied with 12 V and is controlled on the ground side.

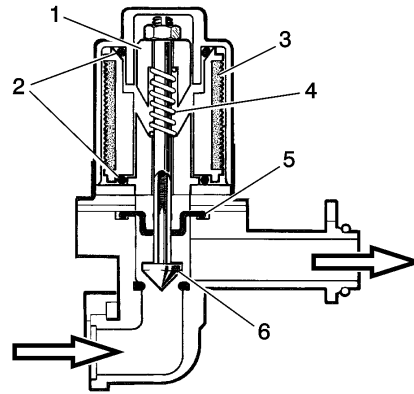

T8008663

- 1 Iron core and spindle
- 2 O-ring
- 3 Electromagnet
- 4 Spring
- 5 Rubber seal
- 6 Non-return valve

Water Valve MCC/BAS

It is regulated by a linkage between the heater control stepper motor and the water valve.

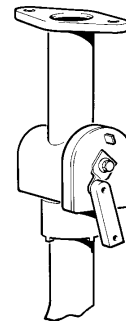

T8009529

A/C System Components

Compressor

The compressor is the working component in the air conditioning (A/C) unit. It works as a pump in the system, since it draws up the evaporated refrigerant from the evaporator and forces it into the condenser.

There is a mechanical safety valve on the cylinder head of the compressor (VN), which opens when system pressure exceeds 31 bar (450 PSI). There is a plug on top of the compressor where air conditioning compressor oil can be topped up.

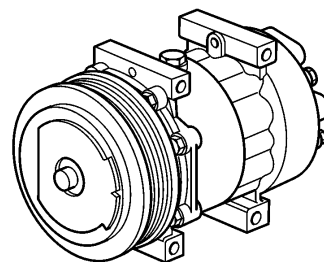

T8008641

Compressor Coupling

The compressor coupling is electromagnetic, with a fixed magnet. The electromagnet (1) consists of an annular winding mounted in an iron core, which is screwed to the compressor housing. The rotating section consists of a pulley (2) and a hub (3), which is flexibly fixed to an annular flange (4). The pulley rotates on the compressor, using two ball bearings. When the engine is running, without the air conditioning (A/C) engaged, only the pulley (5) rotates. When the compressor is supplied with current from the switch, temperature sensors or control unit, the circuit in the electromagnet winding is closed and a magnetic field is created. The magnetic force pulls the flange towards the pulley. Friction between the pulley and the flange force the flange to follow the rotation of the pulley, taking the compressor spindle with it.

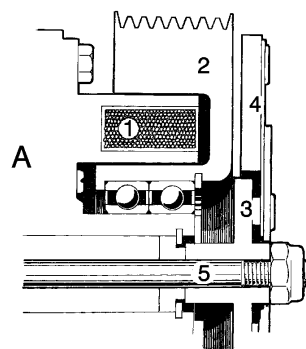

T8008664

A. Compressor disengaged

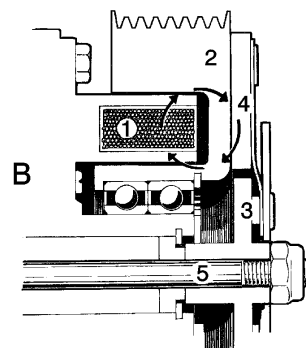

T8008665

B. Compressor engaged

Compressor Mounting and Driving

The compressor is firmly mounted on the engine. It is driven by a poly-groove-belt run off the crankshaft pulley, together with the alternator. Belt tension is adjusted automatically.

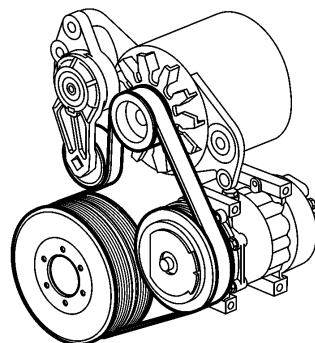

D12

T8009813

Condenser

The condenser is of the parallel flow type, and consists of two side tanks connected by flat pipes. These pipes are provided with flanges for heat transfer. The terminals are of the block type, sealed by double O-rings.

The condenser is permanently mounted on brackets in front of the engine radiator. It is cooled by ambient air drawn by the engine cooling fan and the slipstream which flows through it.

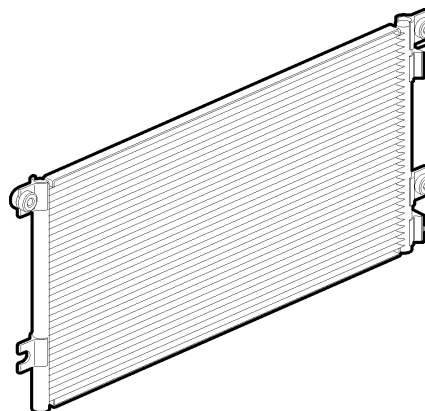

T8009812

Electroviscous Engine Fan

The engine cooling fan is requested in certain conditions. It is used in order to keep the pressure in the air conditioning system down and to maintain good performance. The Electronic Climate Control (ECC) and Manual Climate Control (MCC) inform the engine control unit (via PID 50) when the air conditioning compressor magnetic clutch is activated. The engine control unit then activates the fan in the following cases:

- 1 The engine control unit activates the fan when the air conditioning compressor magnetic clutch is activated and the following conditions are met:
 - The speed of the vehicle is < 45 km/h (28 mph)
 - The outside temperature is > 40°C (104°F)
 - The engine speed > 1500 rpm
 - 2 The engine control unit activates the fan when the air conditioning compressor magnetic clutch is activated and the following conditions are met:
 - The speed of the vehicle is < 45 km/h (28 mph)
 - The outside temperature is > 30°C (86°F)
 - The engine speed > 1200 rpm
 - 3 The engine control unit activates the fan when the air conditioning compressor magnetic clutch is activated and the following conditions are met:
 - The speed of the vehicle is < 20 km/h (12 mph)
 - The outside temperature is > 30°C (86°F)
 - 4 The engine control unit activates the fan when the air conditioning compressor magnetic clutch is activated and the following conditions are met:
 - The speed of the vehicle is < 10 km/h (6 mph)
 - The outside temperature is > 20°C (68°F)
 - 5 The engine control unit activates the fan when the air conditioning compressor magnetic clutch is activated and the following conditions are met:
 - The ECC and MCC control units transmit a request to the vehicle control unit to activate the engine cooling fan (via hard wired signal) if the pressure in the air conditioning system exceeds 20 bar (290 PSI). The vehicle control unit transmits the request onwards to the engine control unit (via J1939 message) which activates the engine cooling fan.
- If the air conditioning pressure falls below 17 bar (246 PSI), the control units transmit a request to switch off the engine cooling fan.

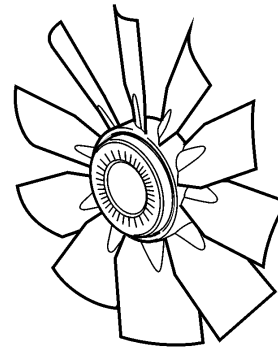

T8008729

On and off operation fans are still used.

Refrigerant Hoses

The refrigerant hoses consist of a polyamide inner surface with rubber exterior.

The hoses have block-fitting unions, sealed with double O-rings.

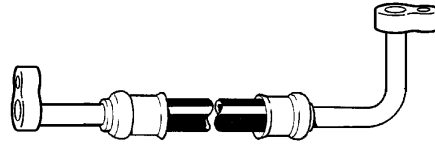

T8008165

Receiver Drier - Refrigerant Reservoir

The drier absorbs any moisture which might be found in the system, and is also intended to filter and store liquid refrigerant before it is forced into the expansion valve.

The moisture-absorbent material which the refrigerant is forced to pass through, before it reaches the outlet, is integrated in a filter body in the reservoir.

The refrigerant mainly arrives at the drier in fluid form. The outlet goes through a pipe in the bottom of the container, to prevent any gaseous refrigerant from passing the drier and reaching the expansion valve. As long as there is enough refrigerant in the system, no gas can reach the expansion valve.

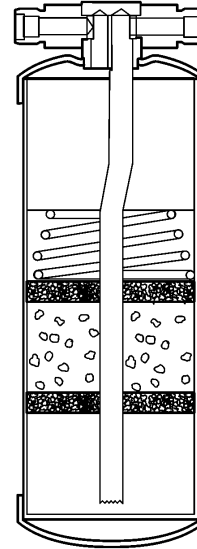

T8009814

High-low Pressure Monitor

The high-low pressure monitor is in the delivery line (fluid under high pressure) before the expansion valve in the climate unit.

The high-low pressure monitor tells the control unit if abnormal pressure is reached and disengages the air conditioning compressor.

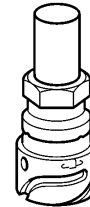

W8003237

Expansion Valve

The purpose of the expansion valve is to regulate the flow of liquid refrigerant to the evaporator and provide a drop in pressure so that the refrigerant will easily absorb heat from the evaporator. The valve is an internally equalized expansion valve that compares the evaporator inlet pressure to the evaporator outlet pressure. This allows for a refrigerant flow consistent with the amount of heat that needs to be absorbed and to keep the evaporator from flooding (a flooded evaporator is highly inefficient and results in very little cooling).

The valve is connected to the evaporator inlet and outlet tubes and on the tube coming from the receiver/dryer and the tube leading to the compressor (see illustration). It is located in the engine compartment next to the bulkhead where the climate control unit tubes pass through.

The amount of refrigerant allowed through the valve is controlled by a push rod and a ball. A diaphragm either forces the push rod down which moves the ball away from its seat or pulls the push rod up which allows a spring to push the ball closer to its seat. Pressure on the bottom of the diaphragm comes directly from the pressure of the refrigerant leaving the evaporator. Pressure on top of the diaphragm comes from a gas filled tube that is surrounded by the refrigerant leaving the evaporator. Pressure on both sides of the diaphragm causes it to move up or down depending on the refrigerant conditions of temperature and pressure.

As the evaporator outlet refrigerant pressure increases (indicating less refrigerant is needed) it forces the diaphragm upwards to close the valve more. If that pressure decreases, the diaphragm moves downward, pushing the push rod down, opening the valve more.

As the evaporator outlet refrigerant temperature increases (indicating more refrigerant is needed) the diaphragm is forced downward, opening the valve. If the temperature decreases, the pressure on top of the diaphragm decreases, and the valve closes more.

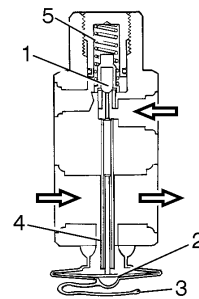

T8008670

- 1 Ball valve
- 2 Diaphragm
- 3 Capillary pipe
- 4 Pressure equalization connection
- 5 Compression spring

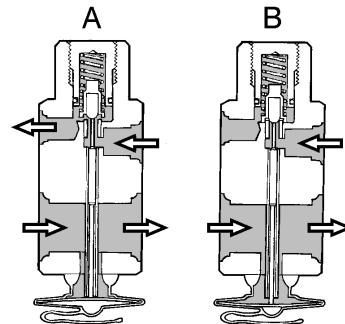

T8008671

Evaporator

The purpose of the evaporator is to absorb heat from the air which is in, or is drawn into the cab. The evaporator is a loop of aluminum tube, with aluminum fins. The inlet and outlet pipes are equipped with O-ring unions for the expansion valve. When in operation water condenses on the outside of the evaporator since it is colder than the surrounding air. Condensation is collected in the base of the climate unit and is drained through a pipe in the front section of the air conditioning unit.

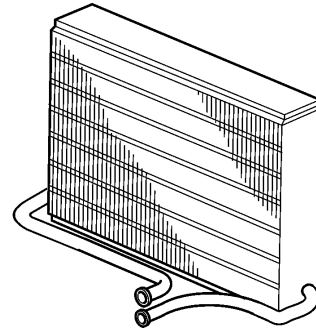

T8009815

Control Panel/Control Unit

The control unit is integrated into the control panel which controls the temperature within the set values. The input signals come from the temperature sensors. The output signals control the water valve, compressor and stepper motors.

The desired temperature, fan speed, ventilation position and recirculation are set using the control panel controls. The climate unit fan speed slows down when the desired temperature is reached.

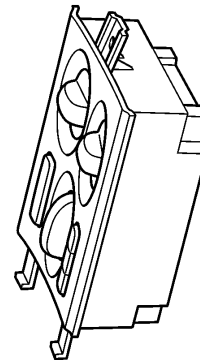

T8008658

Temperature Sensors

The temperature sensors contains a temperature dependent resistor. As the temperature increases, the resistance falls. When the resistance in the temperature sensors falls, a signal is transmitted to the control unit. The temperature sensors are found on vehicles with air conditioning.

The temperature sensors are positioned as follows:

- 1 In the center of the dashboard for the cab air temperature. The sensor also contains a suction fan to draw cab air across the temperature sensor.
- 2 Above the heater core, for the air temperature in the air conditioning unit above the heater core.
- 3 Behind the evaporator, for the evaporator temperature.

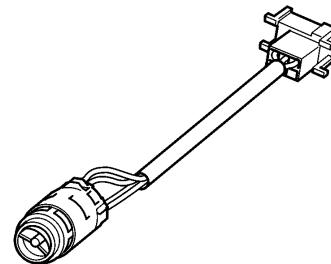

1.

T8009808

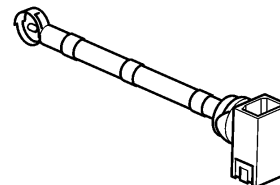

2 and 3.

T8008634

Stepper Motor

There are three stepper motors to set in the climate unit:

- 1 The shutter which mixes fresh air with recirculated air.
- 2 The shutter which distributes outlet air.

Depending on variant ECC, MCC or BAS:

- 3 **ECC:** The shutter which controls the air bypass.
MCC, BAS: The shutter which controls air mixing and the valves that control water flow through the heater core.

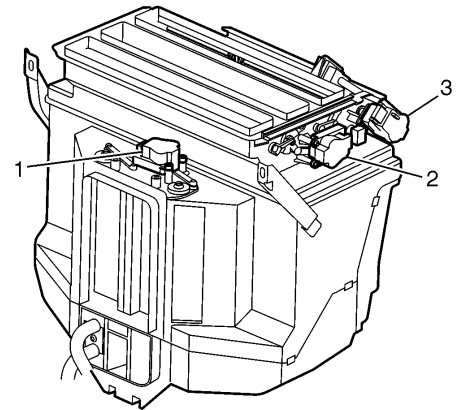

T8008728

Stepper Motor Function

The stepper motor converts electric signals to a stepped, rotating motion.

The stepper motor is constructed of:

- Rotors with permanent magnets.
- Two stator windings with central power supply.

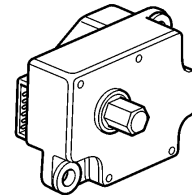

T8008643

Stepper motor.

Turning to the Right Layout Diagram

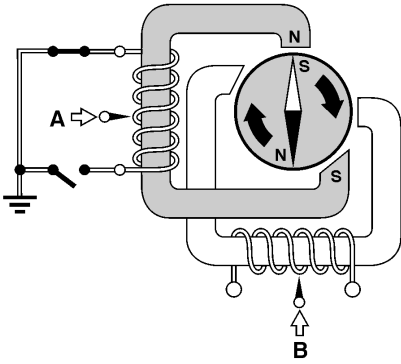

T8008689

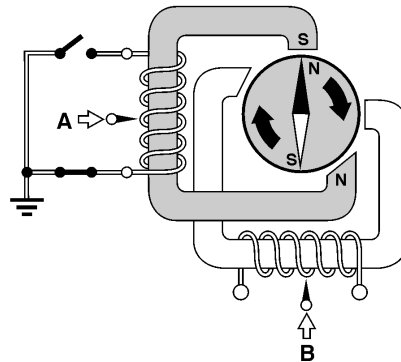

T8008690

Turning to the Left Layout diagram

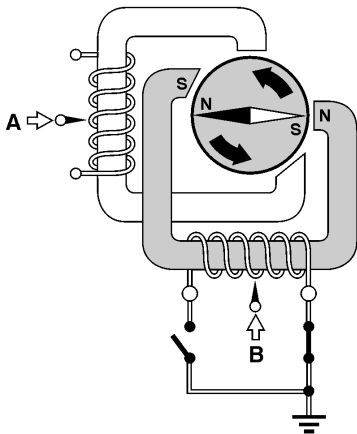

T8008691

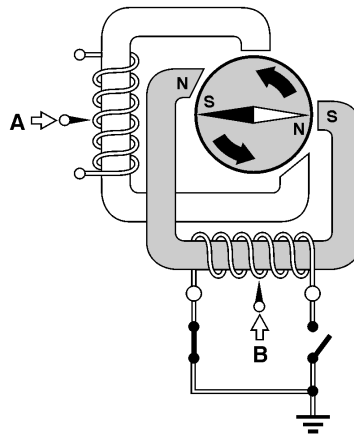

T8008692

The stator windings are supplied with 12 V direct current at A and B. Each winding has three cables, six cables in total, four of which are ground cables. The control unit continually controls the grounding of the stator winding in

different combinations. In this way a rotating magnetic field is created which turns the rotor, step by step. The control unit stores the stepper motor settings on the ignition key to position "0".

O-rings

The O-rings in the air conditioning system seal the pipe joints and the connections. Lubricate new O-rings using compressor oil before fitting.

Note: O-rings can only be used once and therefore must not be reinstalled or reused.

Air Conditioning Compressor Oil



WARNING

Air conditioning compressor oil can be hazardous to health. Use protective gloves and protective goggles when handling the opened container. Ensure there is good ventilation.

Note: The air conditioning compressor oil is hygroscopic (absorbs moisture from the air) and must be stored in a well sealed container.



CAUTION

The oil plug for the air conditioning compressor must never be removed if there is refrigerant in the unit. The oil and refrigerant will discharge.

Note: Only use **PAG SP15** air conditioning compressor oil, **Volvo P/N: 3917742**.

Note: Open connections must be plugged when working on the A/C system for longer than 15 minutes.

The compressor is filled with 300 cc of oil when installed in the factory. Too much oil will impair cooling. Not enough oil damages the compressor. The compressor is supplied from the stores filled with 300 cc of air conditioning compressor oil. When the air conditioning unit has been in operation for a while, traces of oil will be found on all the components of the unit, since the oil follows the refrigerant as it circulates. Carry out the following when repairing or replacing the system: If the hose has ruptured on the high pressure side, most of the oil has probably escaped. There is no need to refill the oil if a new compressor is to be installed. If using the old compressor, first drain off all the oil and then fill with new oil (300 cc). Apply compressor oil to the O-ring on the plug and tighten. Tighten to 10 ±2 Nm (7 ±2 ft-lb).