

# SECTION 1: The Need For Training





# Corporate-Wide Impact

SALE & MARKETING – Customers asking for new features that can only be accomplished through use of a datalink.

SOFTWARE & CONTROLS – Must consider the impact of our control system on all information we send & receive via datalinks, and the system requirements & behavior when replacing wired implementations with communication links.

PRODUCT ENGINEERS – Asked to specify how Allison products should interact with other devices on the vehicle.

APPLICATION ENGINEERS – Almost all of our vehicle OEMs are using datalinks, and we need to be able to help them integrate our product into their vehicle systems.

TECHNICIANS OR SERVICE ENGINEERS – When dealing with datalink-based applications in the field, we need to understand how to diagnose and fix them.

**Communication links affect virtually every area of Allison!**



# Product Evolution & Complexity

MECHANICAL – ‘Old school’ AT transmissions with kickdown linkages and governor weights.



Things can be seen & touched; diagnose by eyeball and intuition.

ELECTRICAL – I/Os interacting with a vehicle through wiring & relays.



Multi-meter or test light needed to tell what's active and what's not.

ELECTRONICS – WTEC. Basic information links & diagnostics, plus simple items like throttle position.



Use of hand-held service tools like the Pro-Link to read out fault codes.

**CONTROL NETWORKS** – Lots of information sharing & interaction, devices controlling each other.



PC-based tools, harder to determine cause & effect, who's controlling whom.



# Changing Responsibilities

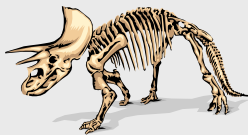

## TRADITIONALLY

- **WIRING** was the only interface available – no other choice!
- WE defined **specific I/O wiring** to implement a vehicle functions.
- WE completed entire FMEAs on 'our' features.
- WE defined the exact physical implementations; **OEMs could not deviate.**
- OEMs were **passive** in terms of integration, simply packaging wires & relays as necessary.

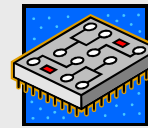

## TODAY

- **COMMUNICATION LINKS** are becoming the interface of choice.
- Instead of wires, we now talk in terms of **messages & parameters.**
- As a *part* of the vehicle OEM's system, we can't complete a system FMEA; we can only give advice.
- OEMs are more **aggressive** and creative in attempts to differentiate their product in the marketplace.
- OEMs are using our information in ways we haven't expected.



# Training Goals

1. Understand why datalinks are important to Allison.
2. Be able to converse more intelligently about datalinks – Know the terminology.
3. Learn the correct way to wire a J1939 system.
4. Understand the options available for connecting 4<sup>th</sup> Gen TCMs to J1939.
5. Understand datalink failure modes and troubleshooting principles.
6. Learn where additional information can be found.
7. Arm you with information to help OEMs.

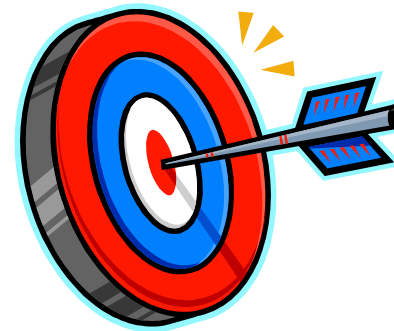

**Not everyone is going to become a datalink expert...but it's okay if you do!**

# SECTION 2: Why Use a Communication Link?





# Complex Wiring for a Given Function

- Traditionally, integrating transmissions into vehicles meant lots of **hardware; wires, switches, sensors, and relays.**
- Each vehicle function has its' own circuit diagram.
- Simple things like 'enabling a retarder' aren't so simple... there can easily be 30 or 40 wire connections involved!

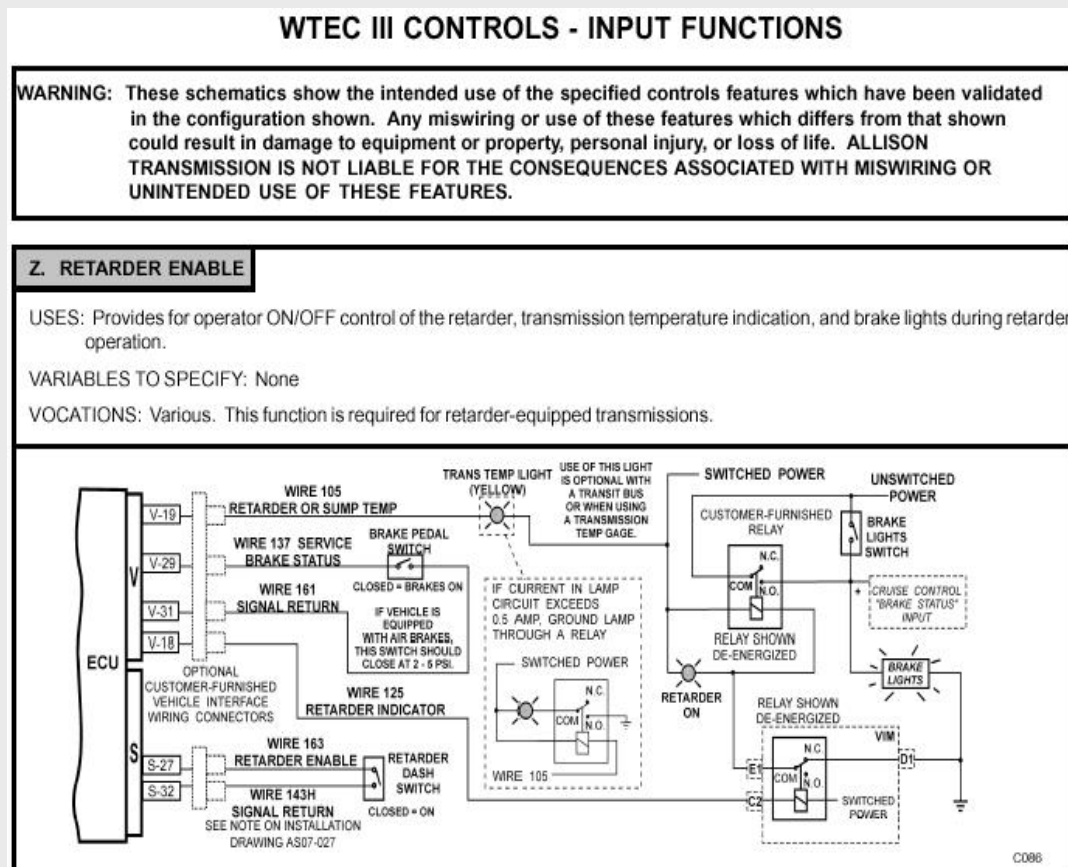



# Complex Function Integration

Following this path for each function means more wires, switches, sensors and relays.

...Interlocks between these functions take more wires and relays to connect them.

...Driver interaction means more wires going through the cab firewall bulkhead connector.

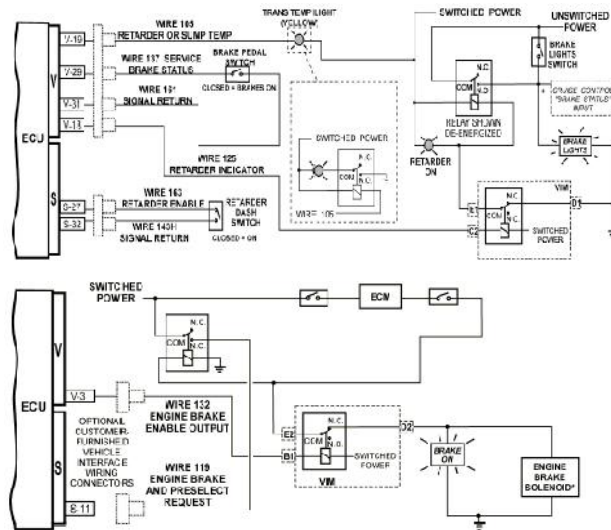
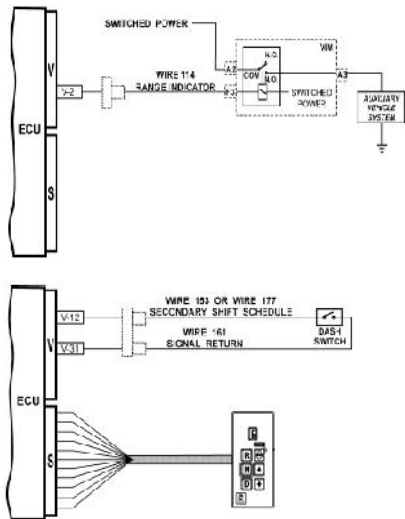



# Sensor Redundancy

Have you ever seen an engine cooling system manifold that looks like a porcupine?



One sensor to run the radiator fan...



One to run the cab temperature gauge...



One switch to run the cab coolant alarm...

And, of course, adding electronic controls didn't help:



One sensor for the engine controller...



One for the retarder controller...

**ALL measuring  
the same piece  
of information!**



# Standardization

- VERTICALLY INTEGRATED manufacturers make or specify all of the components in-house.
- Vertically integrated manufacturers have the luxury of specifying how electronic components interface with each other -- Standardization isn't a problem; it's dictated.
- Auto manufacturers (like GM) are typically vertically integrated.
- In the Heavy Duty industry, many European OEMs tend to be vertically integrated (Mercedes, for example).

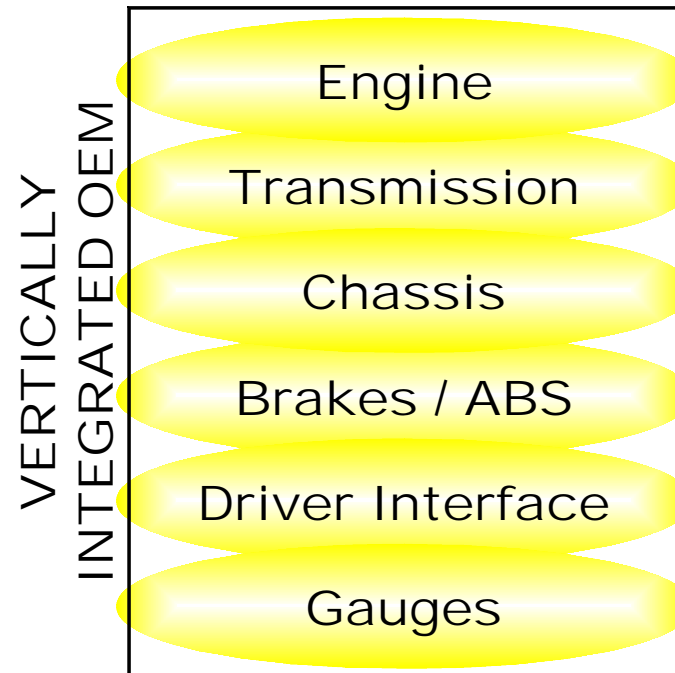



# Horizontal Integration

- HORIZONTALLY INTEGRATED manufacturers assemble 'generic' components from many different suppliers, as specified by the customer.
- Typical heavy truck manufacturers only design frames, cabs and interiors.
- These vehicle manufacturers are faced with the task of making the many potential component combinations work together. Custom wiring is a big part of this.

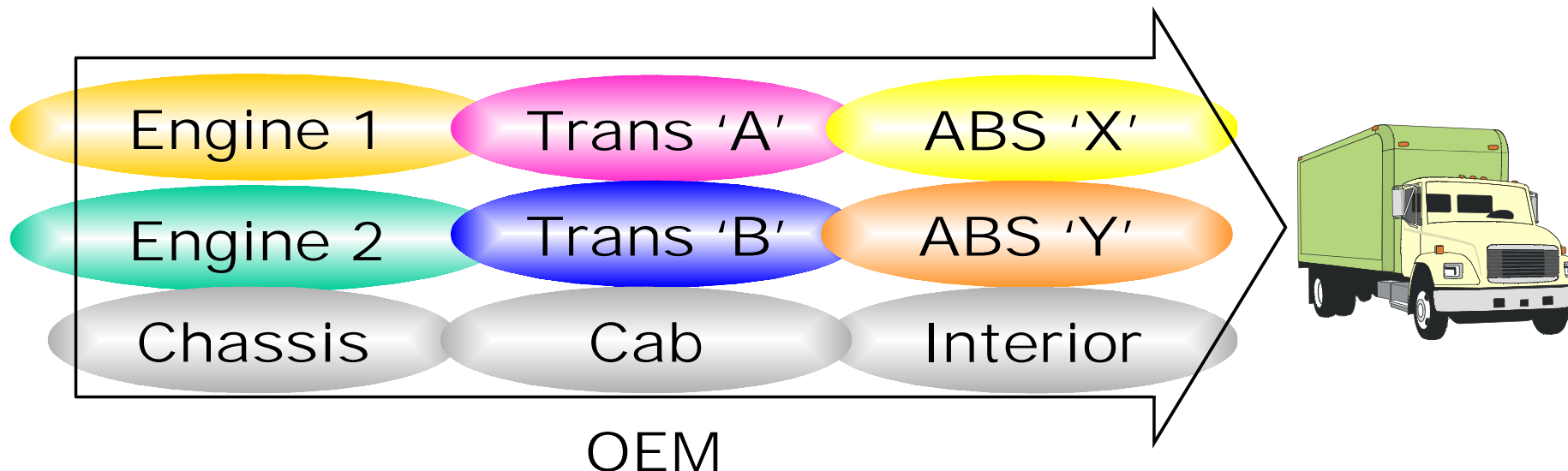



# A Common Answer

It would be **GREAT** if there was a way to:

- ✓ Reduce the amount of wiring in vehicles.
- ✓ Eliminate redundant sensors.
- ✓ Simplify vehicle manufacturing.
- ✓ Reduce the failure modes in a system & simplify troubleshooting.
- ✓ Increase component compatibility across markets.
- ✓ Add new vehicle functions with minimal hardware redesign or changing pin-outs.
- ✓ Allow various vehicle systems to communicate what's going on in their area, using the same language.

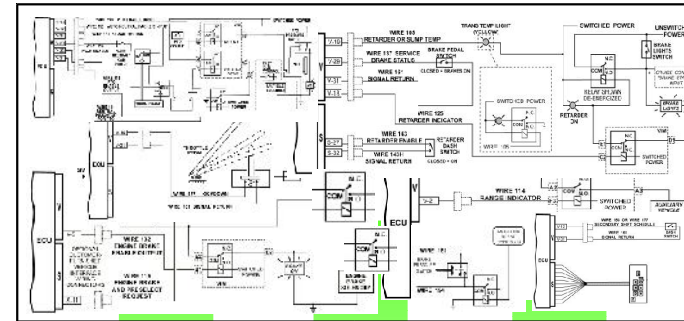

**A datalink can help  
with all of these!**

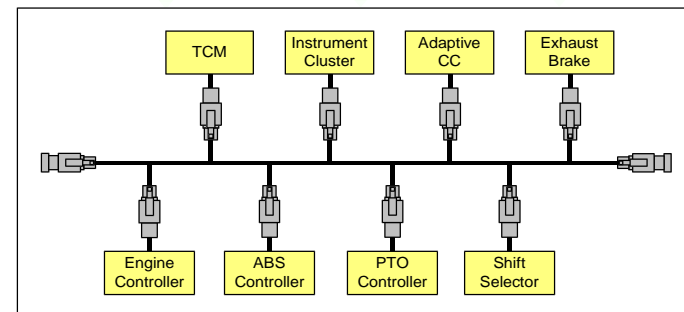



# Allison Reasons: BENEFITS

- LOWER INSTALLED COST
  - ✓ Component standardization and interchangeability throughout the industry
  - ✓ A more common vehicle interface between LCT and WT
  - ✓ Fewer wires in a vehicle...and just as important, *less specialized* wiring
- IMPROVED DURABILITY via Shift Energy Management (SEM)
- UPRATES & EXPANDED APPLICATIONS through features like LRTP
- SIMPLIFIED FAILURE ANALYSIS & TROUBLESHOOTING
  - ✓ Datalink failures are very definable
  - ✓ Responsibility for wiring failures rests more on the vehicle OEM
- NEW, ADVANCED FEATURES
  - ✓ Grade Braking and Cruise Grade Braking
  - ✓ Vehicle Mass Detection
  - ✓ Mass custom shift patterns for better performance and fuel economy

K. Karch – 2005 J1939 Training



# Allison Reasons: **COMPETITION**

- COMMUNICATION LINKS ARE A BASIC REQUIREMENT – To remain a player, electronic integration with the entire vehicle is a ‘must’. Also, Heavy Duty OBD is coming soon, and we must meet government regulations.
- AUTOMATED MANUAL TRANSMISSIONS (AMTS) – A high level of electronic integration has been required for their success:
  - ✓ Closely integrated from inception; better poised to take advantage of it.
  - ✓ We’re stilling catching up to their level of integration with brakes, cruise, etc.
- CUSTOMERS EXPECT MORE FROM US – Longer life, better shift quality.
- CUSTOMERS WANT MORE FEATURES – Engine control & communication with other on-board controllers are necessary to make those features happen.
- WE WANT TO LEAD OR AT LEAST KEEP PACE – The level of transmission integration shouldn’t be a deciding factor for our end customers.

**IF WE DON'T SUPPORT DATALINKS, WE WILL BE LEFT BEHIND!**

# SECTION 2: Why Use a Communication Link?

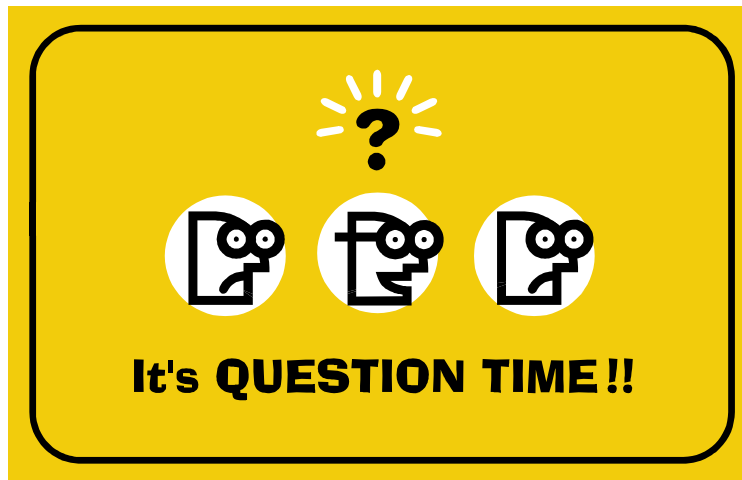



# SECTION 3: Datalinks Basics & Some History



# Terminology: Many Ways to Say the Same Thing!

- In practice, the following 'base' terms are used interchangeably:

LINK – Any path of communication path between two or more computers.

NETWORK – A set of computers connected together.

BUS – The main avenue of communication inside a computer (or system).

- These are often prefaced with words like Data, 'Comm', Communication, Serial, Vehicle, etc. I prefer:

DATALINK - Any path of communication between two or more computers for the purpose of transmitting and receiving data.

- Another important definition to note:

SERIAL COMMUNICATION – Method of transmitting data one bit at a time. Only ONE controller can be talking at any given point in time; all others are listening.

- Beyond these are specific words referring to software and / or hardware standards being used: 'SAE J1587', 'SAE J1939', CAN, 'ISO 11898', etc.



# Basic Communication Flow

In simplest form, a datalink is one controller sending information across a network to another controller:

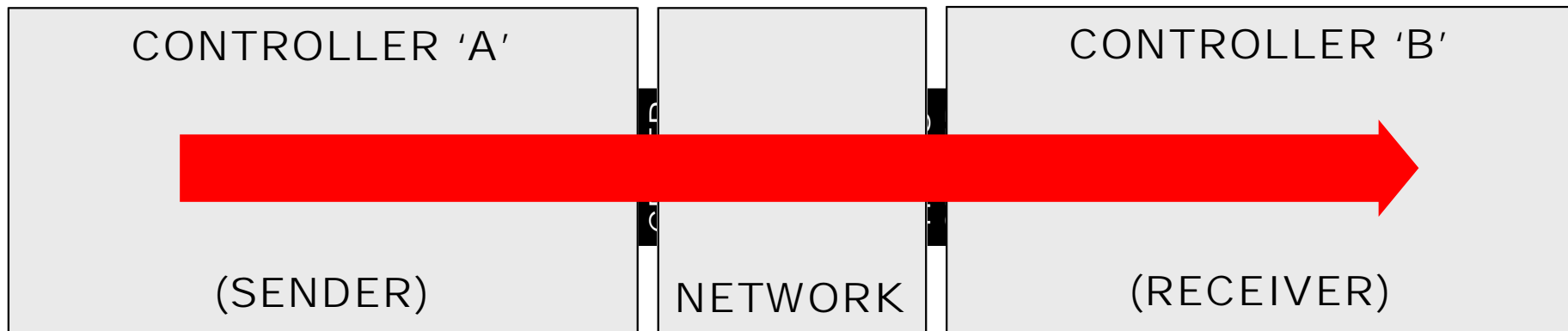

Regardless of size or type, all networks share some similar, basic characteristics:

- **TRANSFER MEDIUM**
- **ACCESS & CONVERSATION**
- **TOPOLOGY**
- **NAMING & ADDRESSING**
- **MESSAGE STRUCTURE**
- **DATA STRUCTURE**



# SAE J1708 and J1587

- First came into use around 1988.
- J1708 is the **hardware specification**; it defines the physical datalink -- microchips, wires, etc.
- ‘Point-to-point’ wiring; no significant restrictions.
- J1587 is the **communication protocol**; defines messages and parameters.
- J1587 is still used today to...
  - ✓ Communicate information (“engine speed is...”)
  - ✓ Calibrate and troubleshoot (service tools)
  - ✓ Relatively cheap and simple
- Two major drawbacks:
  - ✗ Destructive communication
  - ✗ **Slow -- 9600 baud rate**

K. Karch – 2005 J1939 Training

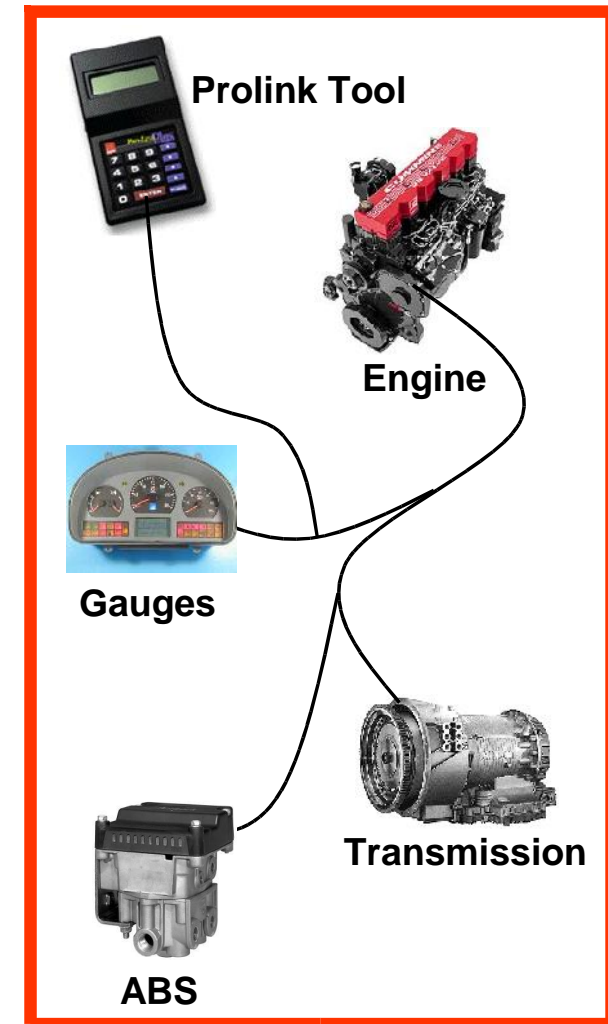



# SAE J1939

- Established by SAE in 1994.
- Based on the Bosch CAN 2.0B specification.
- J1939 is a **series of documents** that define everything about the protocol; hardware, messaging and overall datalink structure.
- Key benefits:
  - ✓ Over 25x faster than J1587 (250Kb vs. 9.6Kb)
  - ✓ Message arbitration (NO destructive collisions)
  - ✓ Intelligent error detection by the hardware.
- Because of the higher speed, a linear network is used; more wiring requirements than J1708.
- We will learn more detail about each of these as the training package continues.

K. Karch – 2005 J1939 Training

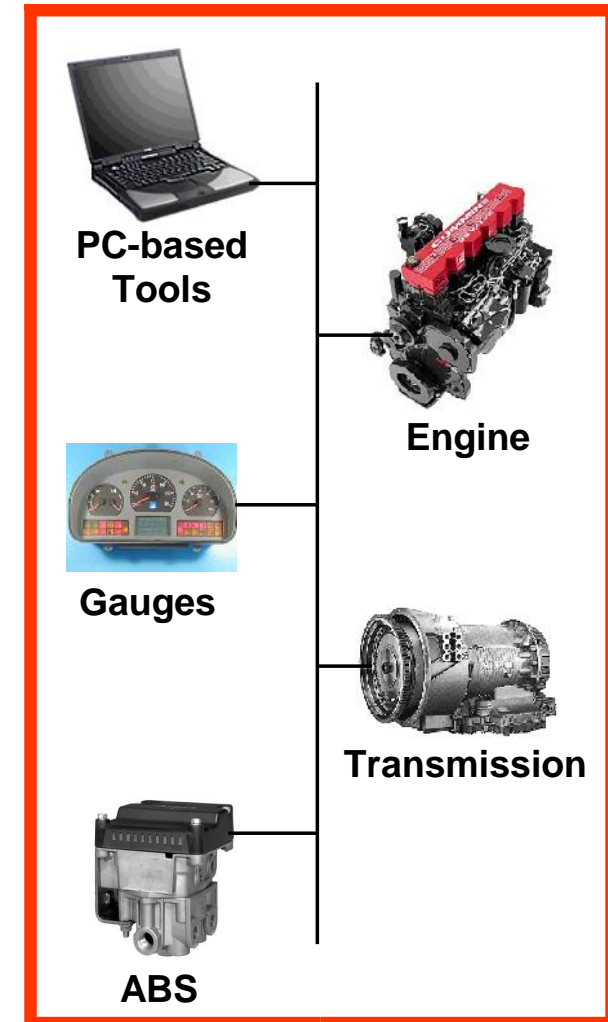

# SECTION 4: Datalink Basics & Some History

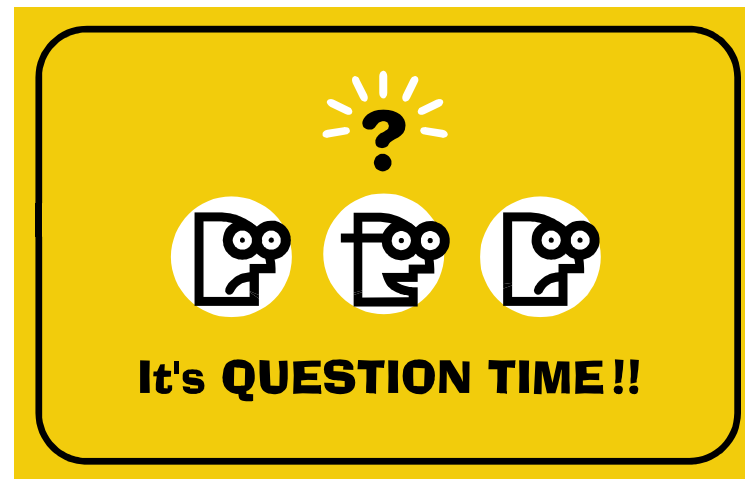

# SECTION 4: Industry Uses for J1939





# Sharing Information

- INSTRUMENT CLUSTERS; virtually all major truck OEMs in NA and Europe, including International, Volvo, Freightliner, PACCAR, Mack, etc.
- ENGINE OEM DRIVER INFORMATION DISPLAYS, such as the Cummins Road Relay, Caterpillar's ID, or Detroit Diesel's Pro Driver.
- AFTERMARKET GAUGES, such as the Vansco transmission gear display.
- SERVICE TOOLS, such as Cummins QuickCheck.



International Truck  
Instrument Cluster



Detroit Diesel  
ProDriver



Vansco Gear  
Display



Cummins  
QuickCheck



# Anti-Lock Brake Systems ( ABS )

- Prevents tires from skidding or locking up under hard braking or low traction conditions.
- On heavy vehicles, ABS systems use J1939 communication to disable any retarders on the vehicle, including engine compression brakes, exhaust brakes, & driveline retarders.
- To prevent engine drag from causing the rear wheels to skid, automatic transmissions release torque converter lockup clutches upon receipt of a J1939 ABS active signal.



Bendix ABS Controller  
and Valve Assembly



# Automatic Traction Control ( ATC )

- Sometimes known as ASR, or Automatic Slip Reduction.
- During hard acceleration or low traction conditions, ATC stops wheel spin by sending J1939 messages to the engine to reduce its' torque output.
- Typically they immediately tell the engine to produce zero torque, then ramp up the allowable engine torque as traction is regained.
- During wheel spin, foundation brakes may also be individually applied to transfer torque to wheels with traction; however, this is not done via J1939.



Automatic Traction Control (ATC) valve



ATC/Relay valve



# Automated Manual Trans (AMTs)

Typically use J1939 commands in a 4-step shift process:

- 1) REDUCE ENGINE TORQUE to take the load off of the transmission gears.
- 2) "WIGGLE" TORQUE across the zero threshold to help the shift actuators attain neutral.
- 3) COMMAND ENGINE SYNCHRONOUS SPEED for the next gear. During skip upshifts, engine compression braking may be commanded on to increase engine deceleration rate.
- 4) RAMP TORQUE BACK UP to the driver's desired level, once the next gear is engaged,.



Eaton Automatic

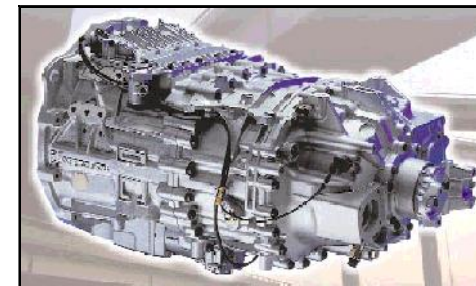

Meritor Freedomline™

In addition, some transmissions have automated clutches that use J1939 commands during the clutch engagement process.

K. Karch – 2005 J1939 Training



# Fire Pump Controllers

- Fire pump controllers control engine speed and torque to maintain proper line pressure.
- Prevents pressure surges and 'hose whipping' when individual nozzles are shut off.
- Sometimes coupled with the ability to read various engine information, such as speed, temperature, etc.



Fire Research  
Pressure Governor



# Headway Controllers

- Sometimes referred to as ACC, or ADAPTIVE CRUISE CONTROL.
- On-board radar tracks the distance to the next vehicle ahead.
- If the truck gets too close, ACC sends J1939 commands to limit engine speed to maintain the gap.
- If the gap remains too small, or continues to decrease, the engine brakes may be activated via J1939.
- May also be integrated with AMTs which downshift to maintain the proper distance.

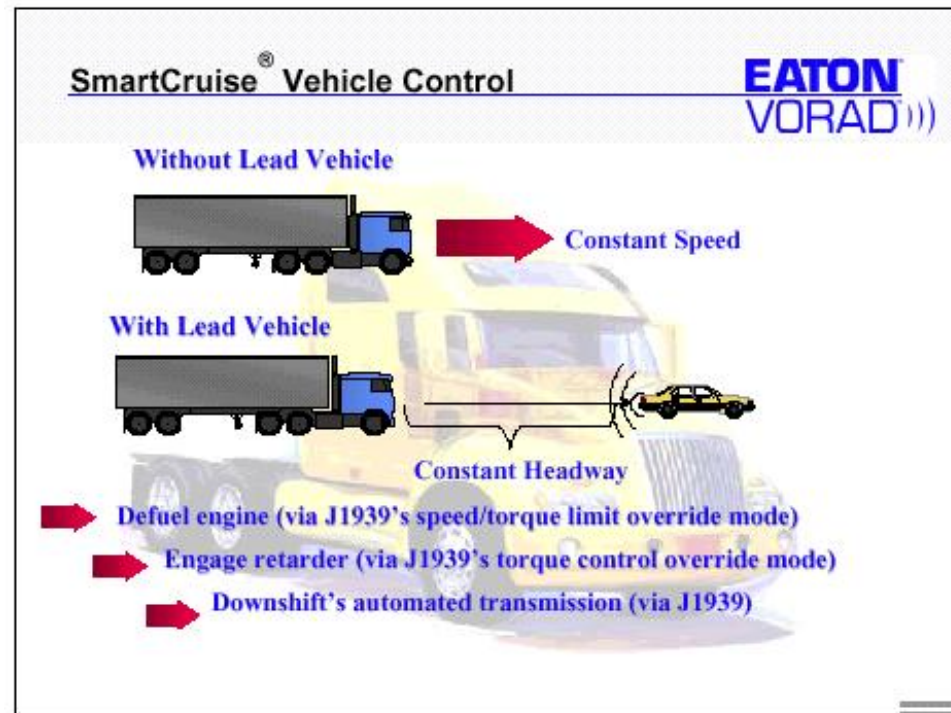

Eaton SmartCruise®



# Electronic Braking Systems (EBS)

- Electro-pneumatic brake system; electronically controlled with air backup.
- Major players today: Knorr-Bremse & WABCO.
- Optimized, seamless blending of retarder(s) and service brakes for a desired deceleration rate.
  - ✓ Reduce brake lining wear & maintenance.
  - ✓ Load-independent 'passenger car' brake pedal feel.
- **Requires accurate torque converter output & retarder control information.**
- Heavily integrated with ABS, ATC, Trans, ACC...
- Foundation for stability & roll control; some talk that EBS may be legislated in Europe.





# SECTION 4: Industry Uses for Datalinks

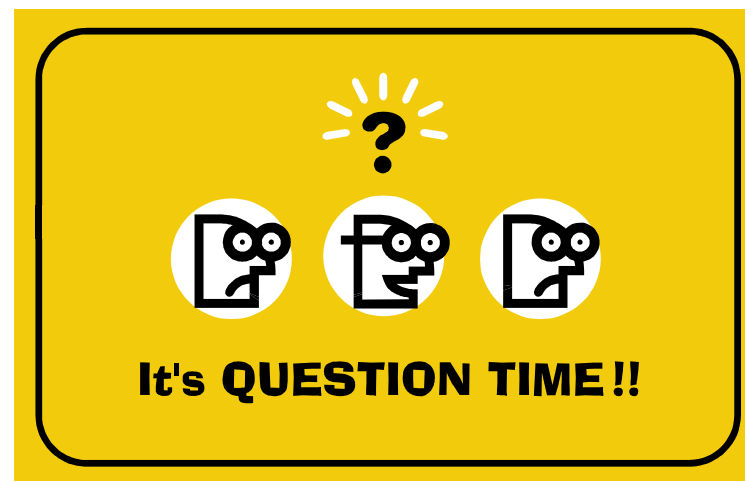

# SECTION 5: J1939 Physical Layer

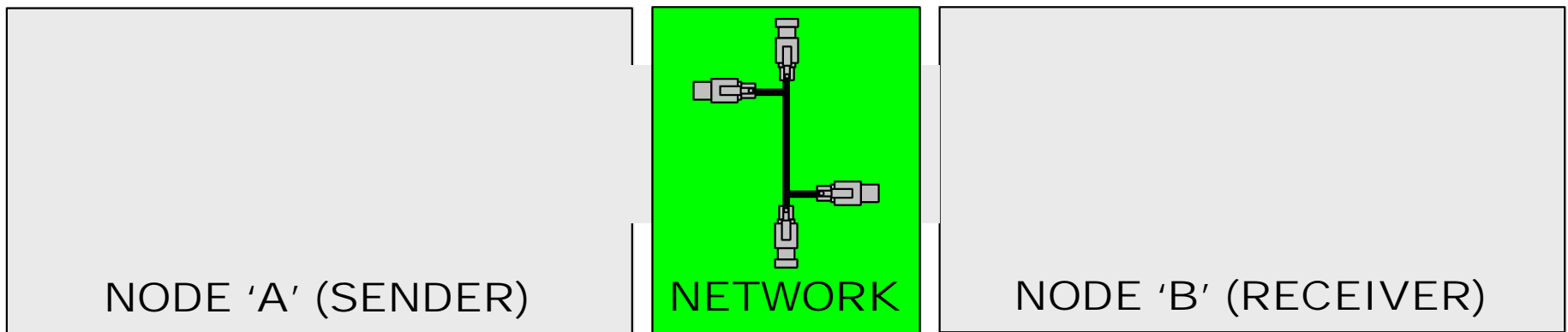



# Physical Layer of a Network

**TOPOLOGY** – Pattern of connections between the devices on the network:

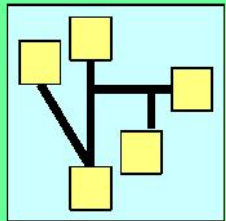

Point-to-Point

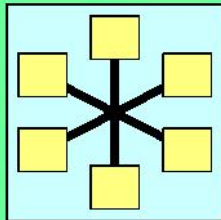

Star

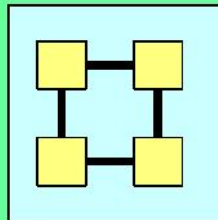

Ring

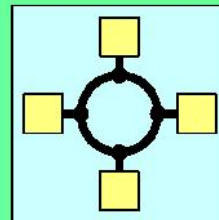

Loop

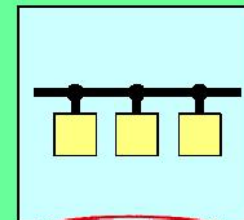

Linear Bus

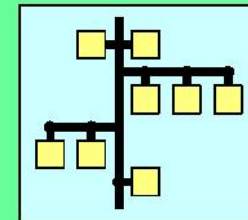

Tree

J1939

**TRANSFER MEDIUM** – Components that physically convey the data.

- Wiring is most common on vehicles, and is what J1939 uses.
- Power Line Carrier (PLC) is superimposes the communication signals on AC or DC power lines. Used with J1587 in tractor-to-trailer ABS communication.
- Other methods include Fiber Optics & Radio Frequency (Wi-Fi, Bluetooth, etc).



# J1939-13 Service Connector

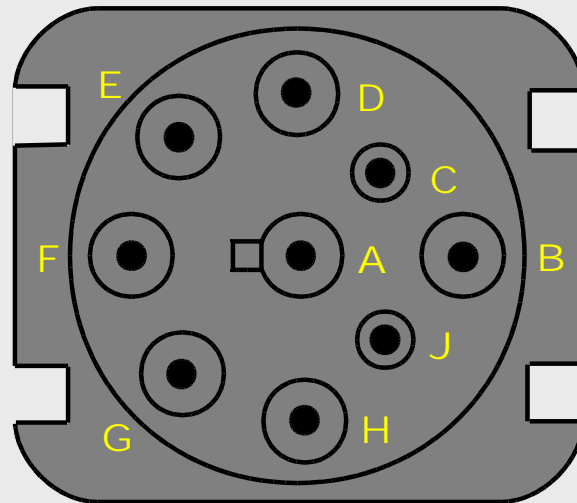

- A = Ground
- B = +12 Volt (Unswitched)
- C = **J1939 High** (Yellow)
- D = **J1939 Low** (Green)
- E = **J1939 Shield**
- F = J1587 + (typ. Blue)
- G = J1587 - (typ. White)
- H & J = OEM use



12 volt pin must be an **UNSWITCHED** supply. Some vehicle and engine controllers require cycling of the ignition switch during the reflash or reprogramming process. If service tool power is lost during a key switch cycle, the controller being programmed may 'lock up'!



# 3-Pin Connectors

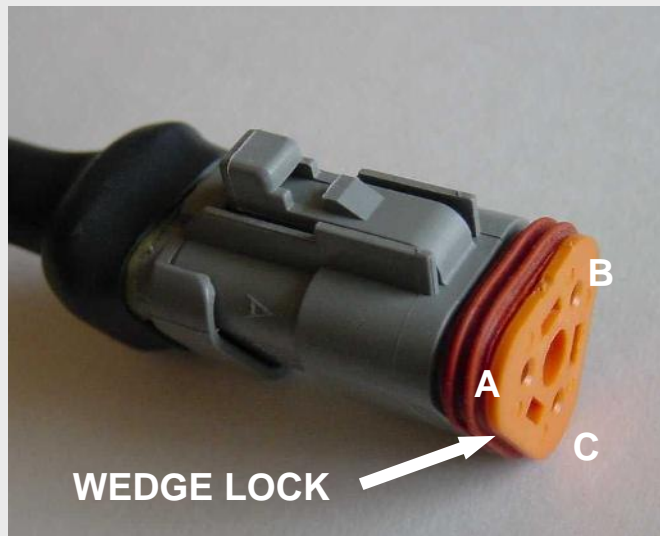

PLUG connectors use 'female' pins. They also retain the seal for the connection joint.

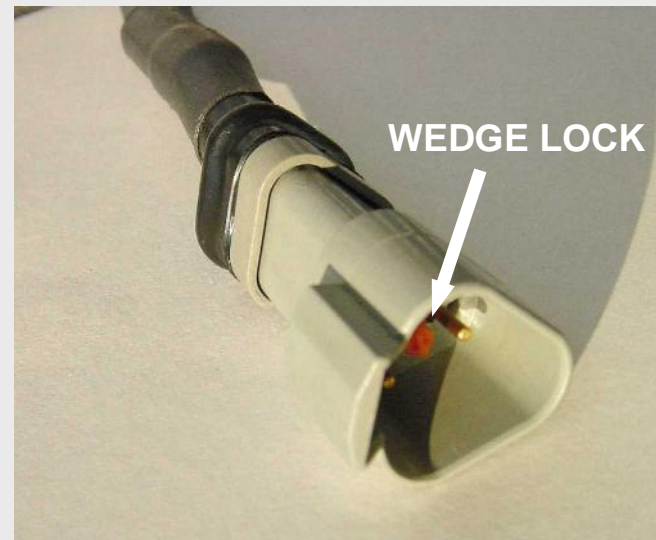

RECEPTACLE connectors use 'male' pins. Both mating connectors must have color-matched wedge locks.



# Plug Connector Improvements



NEW

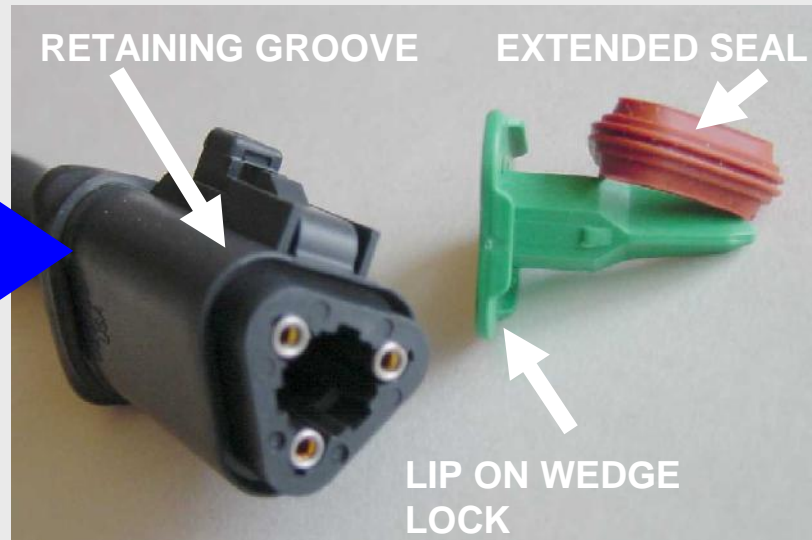

On grey plugs, the seal tended to roll off the connector when unplugged.

Without the seal, water intrusion can short circuit the datalink.

New black plugs designed to capture & lock in the new extended seal.

The orange wedge locks have been changed to green.



*Components* are NOT interchangeable; the correct seals & wedge locks must be used with the correct connector body. However, both plug *assemblies* fit the same receptacle connectors.

K. Karch – 2005 J1939 Training



# J1939-11 Cable Basics

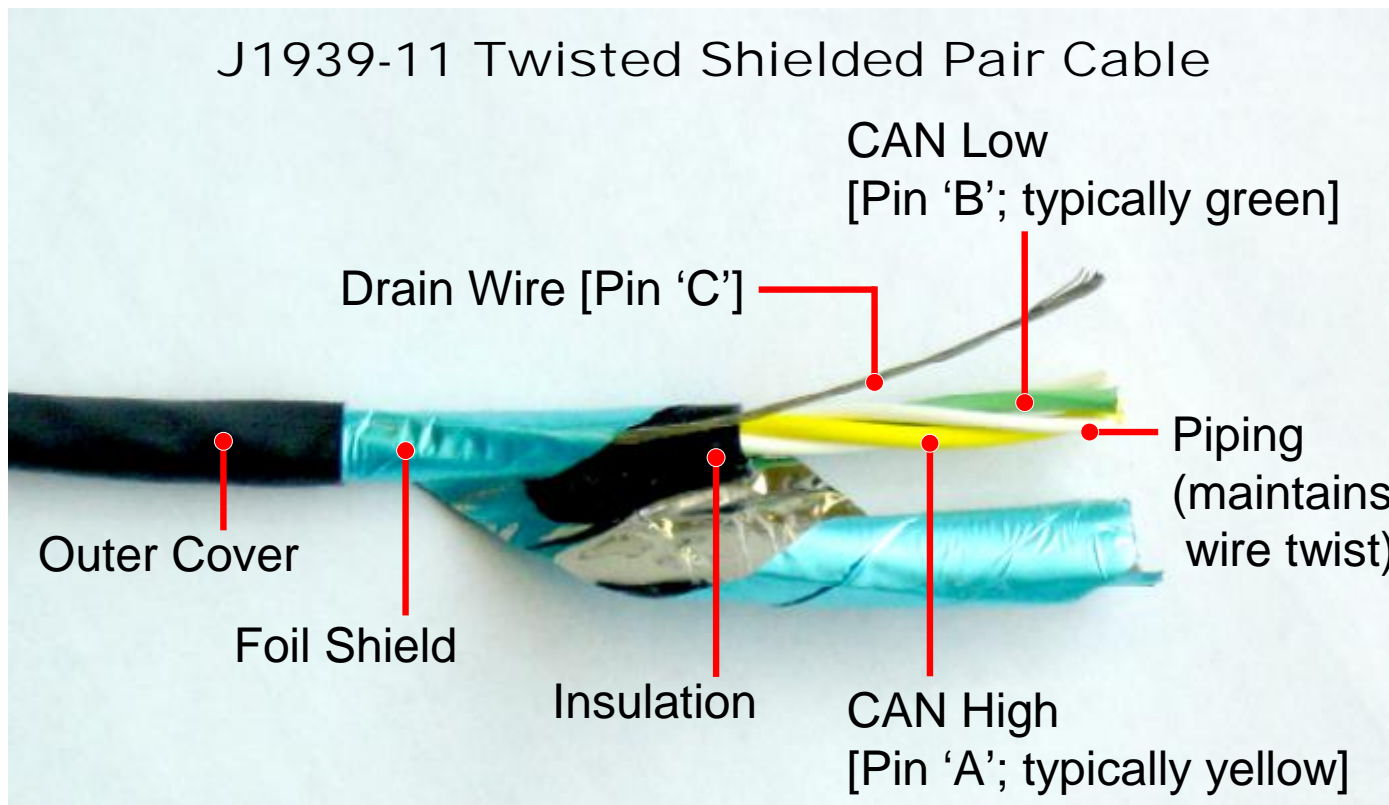

Manufacturers include Belden, BICC Brand-Rex, Champlain, Northwire and Raychem.

One specification you *can't* see is that J1939 cable **MUST** have 120Ω impedance.

So what's impedance?



# Cable Impedance

IMPEDANCE affects the 'the rate of traffic flow' in the wires. It must match the intended volume and rate of traffic. Properly sized, traffic flows smoothly.

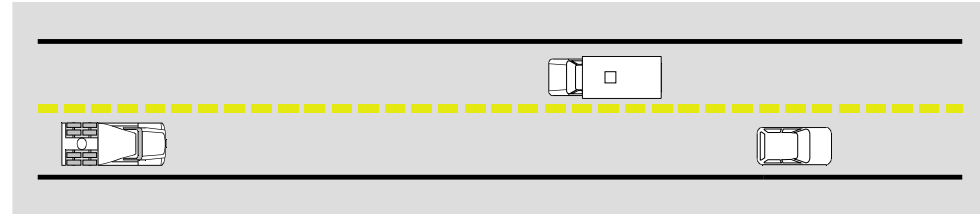

If the wrong impedance wire is used, traffic jams and crashes may result. Messages may get lost, or reflect back in the wrong direction.

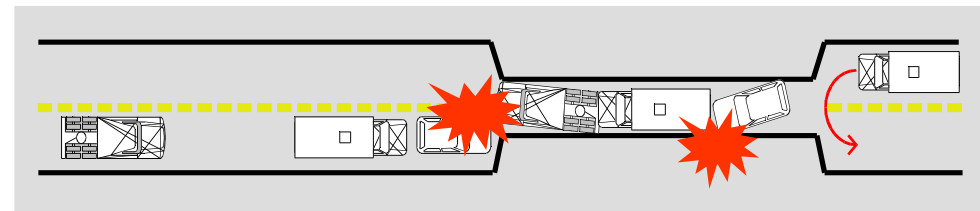

## Sources of Impedance Problems

- Mismatched cables -- Automotive wire (GXL, TXL, etc.) will not work!
- Extremely tight bends in the cable
- Long breaks in shielding, or mixed shielded and unshielded cable.
- Separated conductor strands within the cable
- Spacing of controllers ('nodes') on the backbone

K. Karcher, 2005, H1939 Training

*Building a specific impedance cable is not intuitive; leave it to the cable manufacturers!*



# Cable Shielding

Original J1939 cable is defined in J1939-11, and calls for shielding. Sometimes referred to as ‘-11’ or ‘J1939 Heavy’ cable.



- PRO
- Protects signal integrity; noise hits the shield & shorts to battery ground.
  - Also helps reduce the amount of noise *emitted* by the datalink.
- CON
- Relatively expensive.
  - Difficult to repair in the field.
  - Less flexible, difficult to route.
  - Misapplied, can do more harm than good.



THE SHIELD DRAIN MUST HAVE ONLY ONE LEAD TIED TO BATTERY GROUND, near the center of the backbone. Tying both ends to ground creates a ‘ground loop’, which can *create* noise on the link.

THE SHIELD MUST BE TIED TO THE SHIELD PIN ON EACH CONTROLLER. Their internal connections typically use an RC circuit; they do not tie directly to ground.



# J1939 'Lite' Cable

Shielding woes led vehicle OEMs to develop SAE J1939-15 -- 'J1939 Lite' – *without* the shield or drain. Cheaper, easier to route, manufacture and repair.



- The price is susceptibility to external noise. Quoting SAE J1939-15:

“...vehicle manufacturer shall control ... routing to prevent mutual inductance and / or capacitive coupling of unwanted signals onto the ... wires. Coupled signals may interfere with communications and may degrade or damage the CAN transmission line transceivers over an extended period of time.

The risk of coupling can be reduced by routing ... cable away from high current, rapidly switched loads and the wires connected to these devices, including return paths of ECU ground or power.

... devices and associated wiring to avoid include: starter motors, wiper relays, turn signal (flasher) relays, and lamp relays. Additionally, the routing of the network and stubs should avoid close proximity to emission sensitive components (e.g. radios, CBs, and other electronic components).”

K. Karch — 2005 J1939 Training



'Lite' cable **MUST** be routed away from:

- Solenoids
- Relays
- Flashers
- Starters
- Alternators
- High-power CBs, etc.



# Allison Position on J1939 'Lite'

WE DO NOT RECOMMEND USE OF J1939 LITE.

- Vehicle OEMs are responsible for J1939 wiring, just like other vehicle wiring.
- First line of responsibility for diagnosis and repair relating to any vehicle CAN link or interface wiring lies with the vehicle manufacturer.
- While J1939 Lite presents potential advantages of simplicity and lower initial cost, lack of shielding can make the vehicle system susceptible to EMI.

Such interference is extremely difficult to quantify, predict, and diagnose, and could be generated or influenced by components or modifications performed on the vehicle *after manufacture* by the primary OEM.

- OEM's install J1939 Lite at their own risk and are responsible for the design and validation to assure unwanted signals are not induced in the CAN wires.
- If the use of J1939 Lite causes the transmission to malfunction, Allison is not responsible for costs associated with vehicle modifications or repairs.

K. Karch – 2005 J1939 Training





# J1939 Termination Resistors

A TERMINATION RESISTOR is a 120Ω resistor found at each end of the backbone. Two are required, and they typically use **blue wedge locks**.

Since some vehicle OEMs use receptacles on their backbones, a plug version is also available.

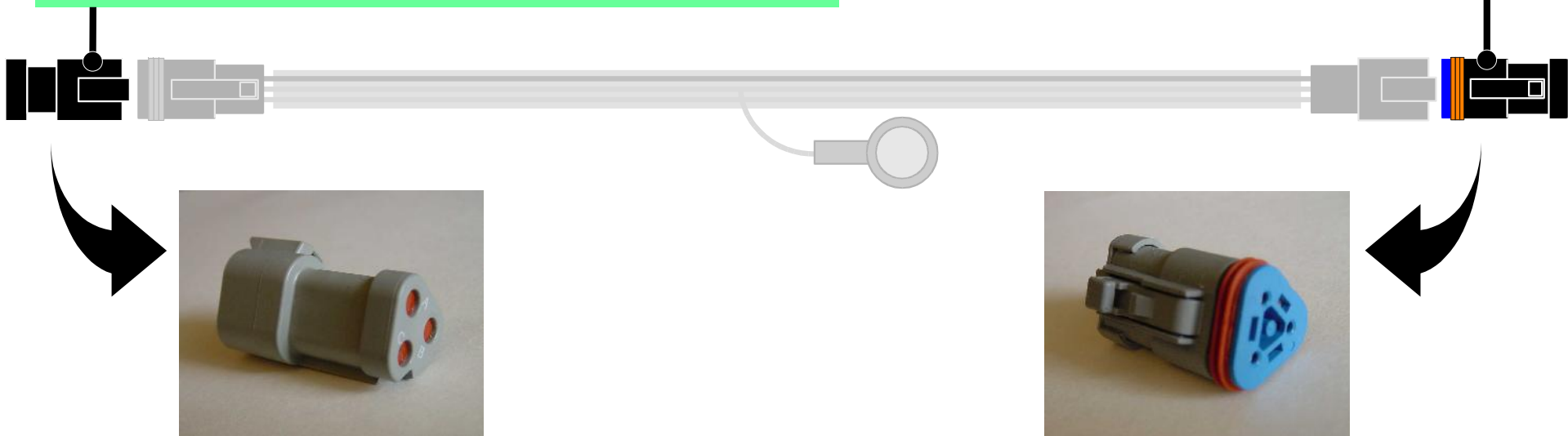

To reduce cost & components, some controllers have an INTERNAL TERMINATION RESISTOR. Such controllers are found at the end of the backbone, such as an ABS controller at the back of the vehicle. **Allison 4<sup>th</sup> Gen TCMs and J1939-based shift selectors have this option.**

K. Karch – 2005 J1939 Training





# Termination Mistakes

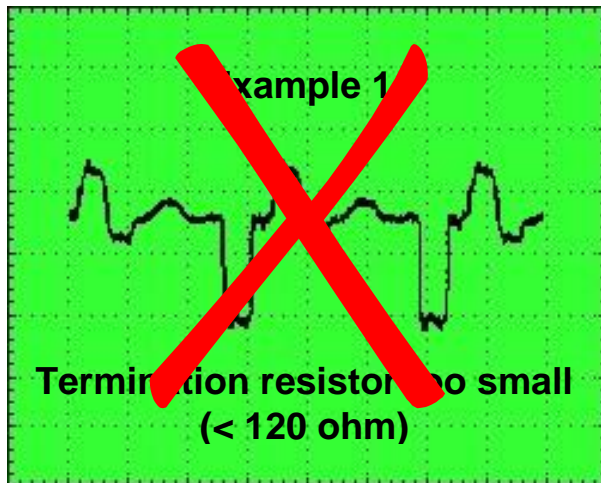

A termination resistor that's TOO SMALL is just like a shock absorber that's too small; *it can't soak up the amount of energy it needs to.*

While the bit states aren't as muddy as with no termination resistor at all, they're still pretty unclear.

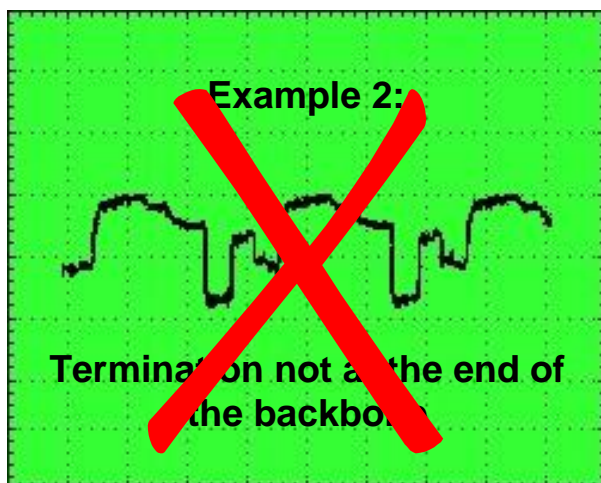

A termination resistor in a WRONG LOCATION can cause all sorts of strange corruption as bits are reflected.



This mistake commonly occurs when extending a backbone for a new controller. You **MUST** move the termination resistor to the “new end” of the backbone!



# J1939 Stubs and Nodes

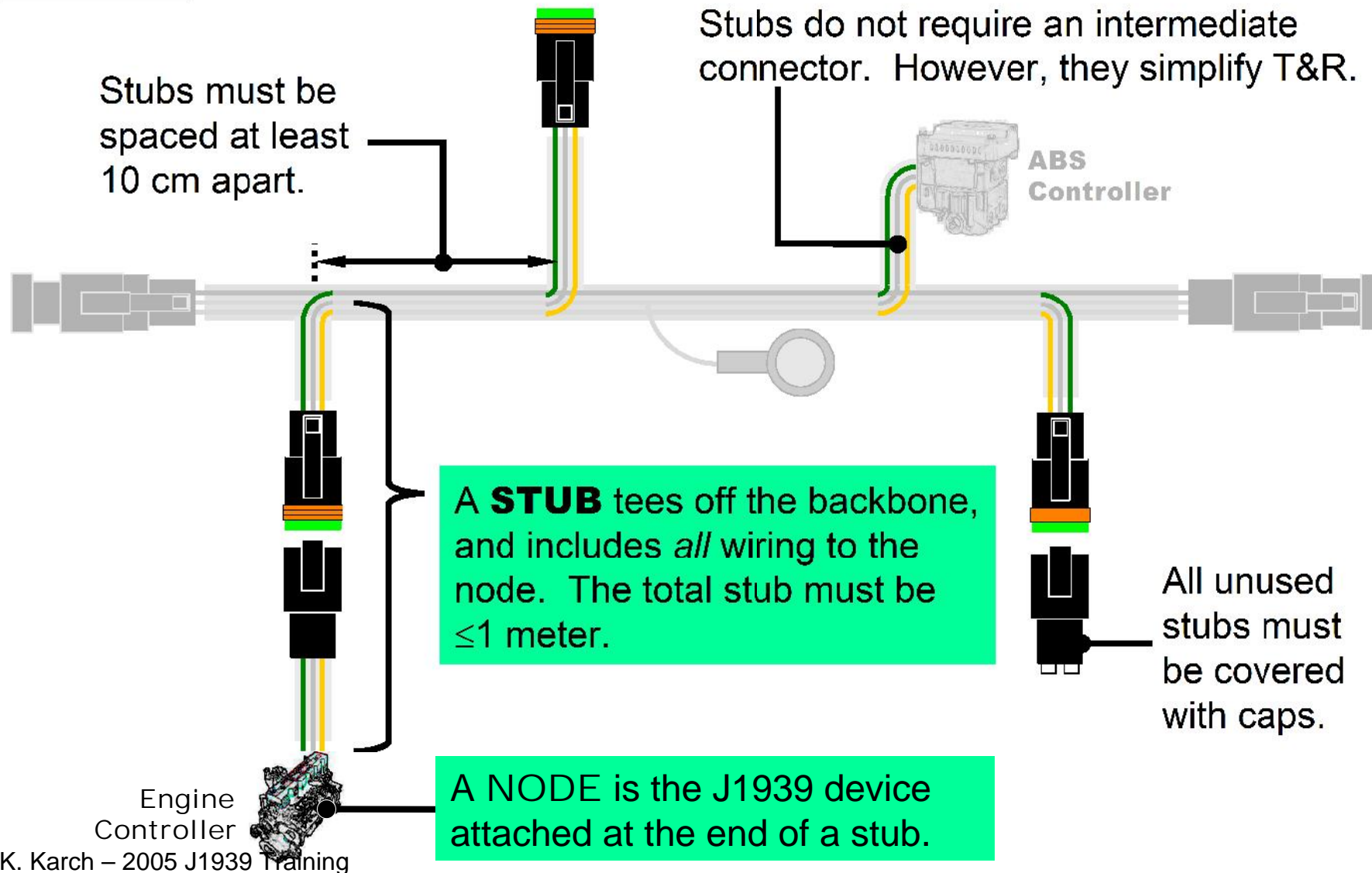



# J1939 Stub Spacing

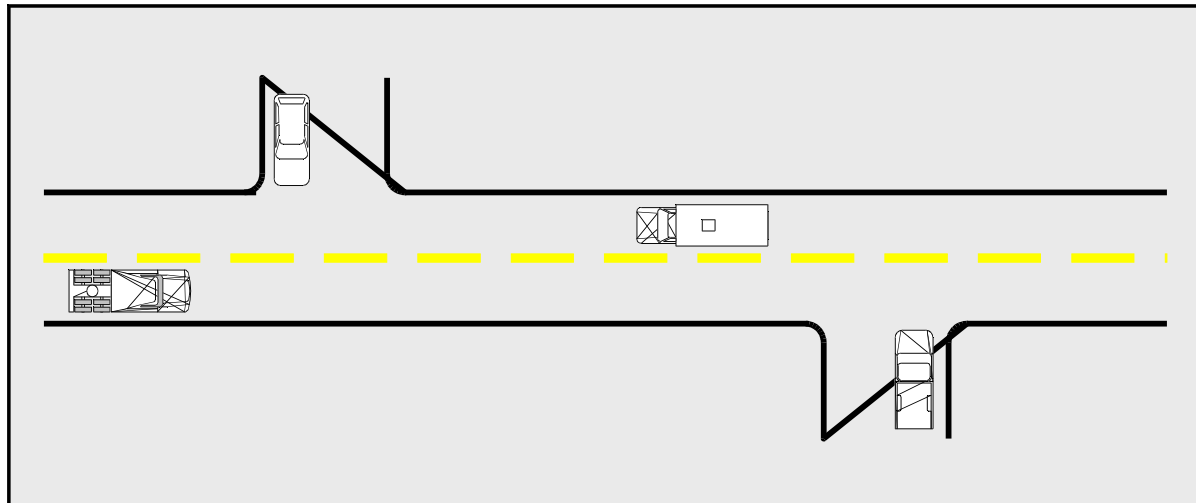

STUB SPACING is like a roadway; with intersections spread apart, it's much easier for vehicles to merge onto the road.

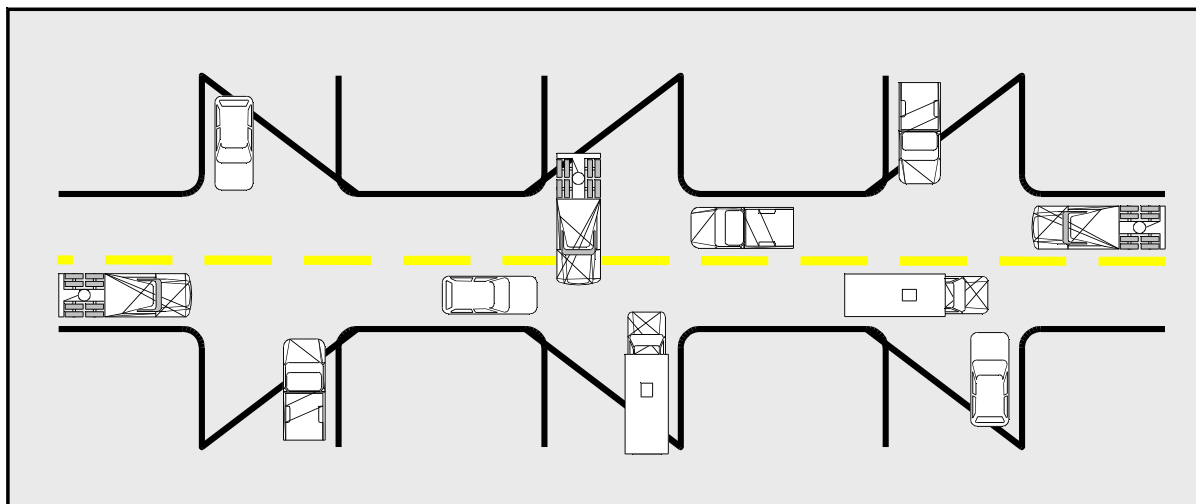

If nodes are placed too close together, a traffic jam is created.



**Terminal strips cannot be used as backbones!**



# J1939 Network Overview: TCM & Selector Stub Interfaces

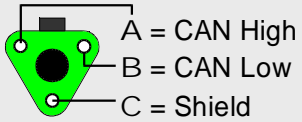

- TCM and selector internal termination resistors **CANNOT** be used with component 'stub' installations.
- TCM 'pass through' connections **CANNOT** be used with TCM 'stub' installations.

K. Karch - 10/11/04

Two 120 ohm **TERMINATION RESISTORS** required; one at each end of the backbone. They always use **blue** wedge locks. Parts shown have the resistor built in the casing.

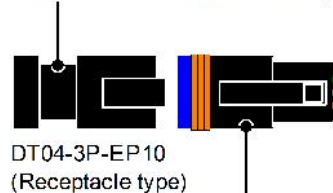

Blue Wedge Lock W3S-1939  
Pins 0462-201-1631  
Housing DT06-3S-E008

**BACKBONE** - the cable between the two termination resistors. It must be 120 ohm impedance cable and  $\leq 40$  m. As shown, the backbone can pass through bulkhead connectors.

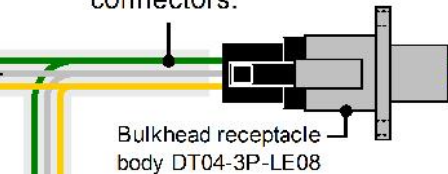

**PLUG** connectors are typically used on the backbone side:

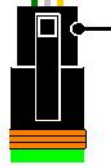

Green Wedge Lock W3S-P012  
Pins 0462-201-1631  
Housing DT06-3S-EP11

**STUB** tees off of the backbone, and includes the length of wiring on the node. Total stub length must be 1 meter or less.

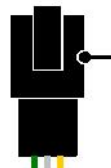

**RECEPTACLE** connectors are typically used on nodes:

Green Wedge Lock W3P  
Pins 0460-202-1631  
Housing DT04-3P-EE01

**NODE** - an electronic controller attached at the end of a stub



Stubs must be spaced  $\geq 10$  cm apart.



NOTE: Wire twist is not shown for clarity.

**SHIELD** drain connects directly to battery ground terminal, and breaks out of the backbone as close to its' center as possible.

OEMs may wire stubs directly to nodes; use of 3-pin connectors is not required. However, they simplify troubleshooting and repair.



## Allison 4<sup>th</sup> Generation TCM

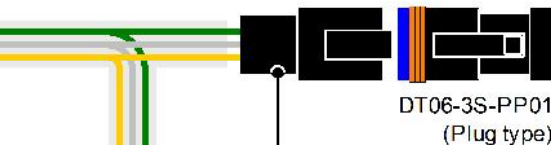

Blue Wedge Lock W3P-1939  
Pins 0460-202-1631  
Housing DT04-3P-EE01

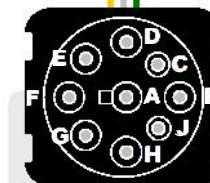

In-Cab Diagnostic Bulkhead Housing HD10-9-1939P

A = Ground  
B = +12 Volt (Unswitched)  
C = J1939 High (Yellow)  
D = J1939 Low (Green)  
E = J1939 Shield  
F = J1587 + (Blue)  
G = J1587 - (White)  
H & J = For OEM use

## Allison-manufactured 3000 / 4000 Series Selector

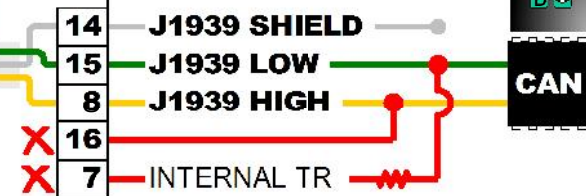



# Connecting 4<sup>th</sup> Gen TCMs & Shift Selectors to a J1939 Network

To meet OEM demands of cost and convenience, Allison 4th Generation TCMs can be interfaced to a vehicle's J1939 network IN ONE OF THREE WAYS:

- OPTION 1 – Traditional Stub
- OPTION 2 – Backbone Termination
- OPTION 3 – Pass Through

Similarly, 3000 / 4000 Series J1939-based shift selectors can be interfaced by:

- OPTION 1 – Traditional Stub
- OPTION 2 – Backbone Termination

Let's take a look...



# 4<sup>th</sup> Gen TCM Internal Termination Resistor

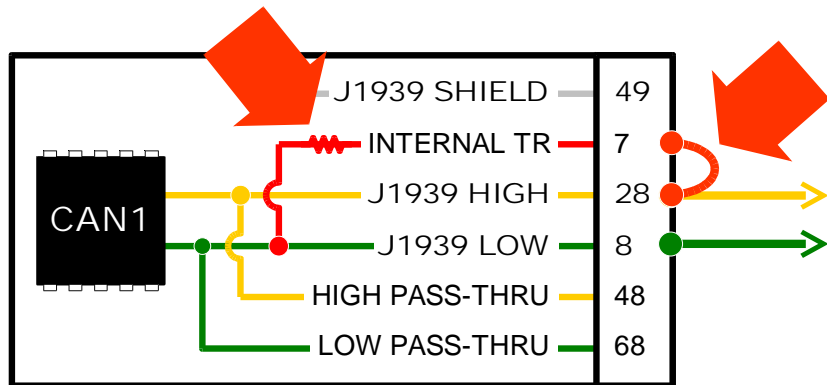

4<sup>th</sup> Gen TCM

4<sup>th</sup> Gen TCMs have an optional INTERNAL TERMINATION RESISTOR that can be connected via a jumper wire in the OEM's harness.

If our TCM is located at one end of the J1939 backbone, this feature can eliminate some hardware for the OEM.

Our J1939-based shift selectors also have an internal termination resistor available.



If used by the OEM, they **MUST** label the component to indicate that the internal termination resistor is being use.

Otherwise, service techs might think one or both termination resistors are missing – when in fact, they're not.



# TCM & Selector J1939 Backbone Termination Interfaces

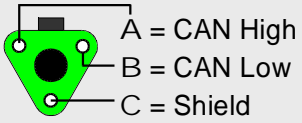

- Components must be clearly labeled indicating 'internal termination resistor' use.
- TCM 'pass through' connections **CANNOT** be used if the TCM internal termination resistor is utilized.
- Only 120 ohm impedance wire may be used for the jumper wires.
- Jumper wire length should be kept to a minimum.

K. Karch - 10/11/04

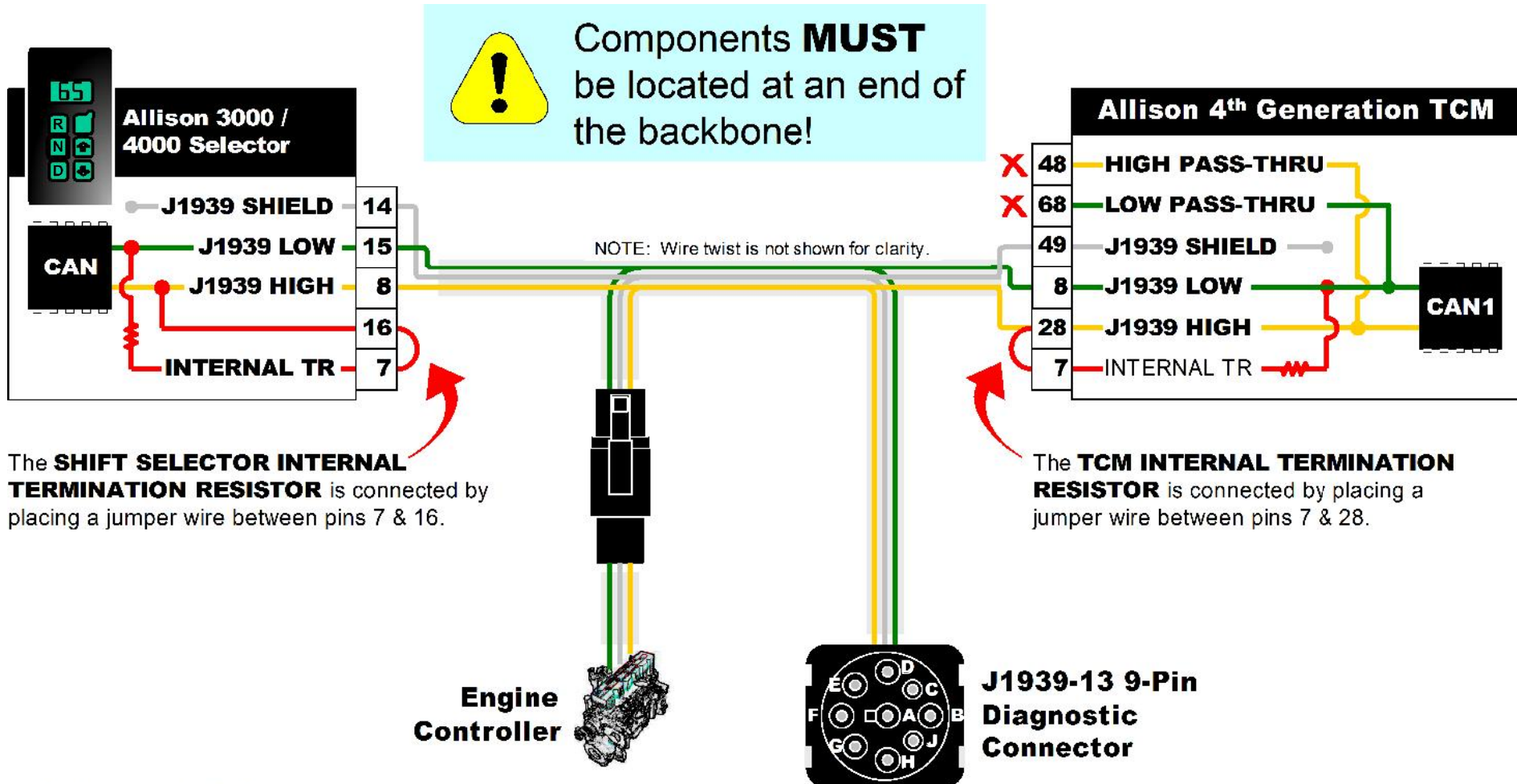

K. Karch – 2005 J1939 Training



# 4<sup>th</sup> Gen TCM 'Pass Through' Pins

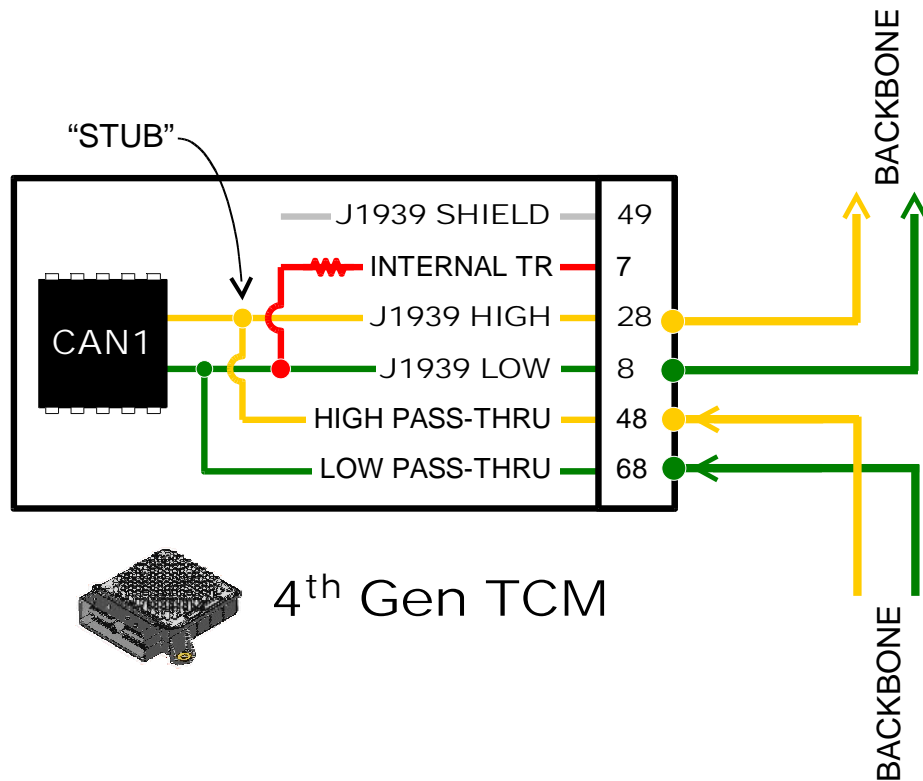

PASS THROUGH PINS allow an OEM to create a backbone without a spliced stub for the TCM.

The backbone is run in one set of pins and out the other...The 'stub' for the TCM is actually the circuit *inside* the TCM.



# TCM J1939 'Pass Through' Interface

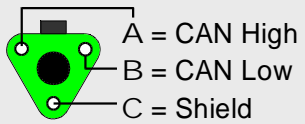

- The TCM internal termination resistor **CANNOT** be used with TCM 'pass through' installations.
- In J1939-11 installations, the shield drain wire must be spliced such that the shield remains continuous.
- Allison-manufactured 3000 / 4000 Series shift selectors do not have 'pass through' capability; must use 'stub' or 'termination resistor' installation.



The TCM INTERNAL TERMINATION RESISTOR **CANNOT** be utilized when the TCM is installed in a 'pass through' configuration.

The SHIELD DRAIN WIRE **MUST** be spliced such that the shield remains continuous throughout the backbone.

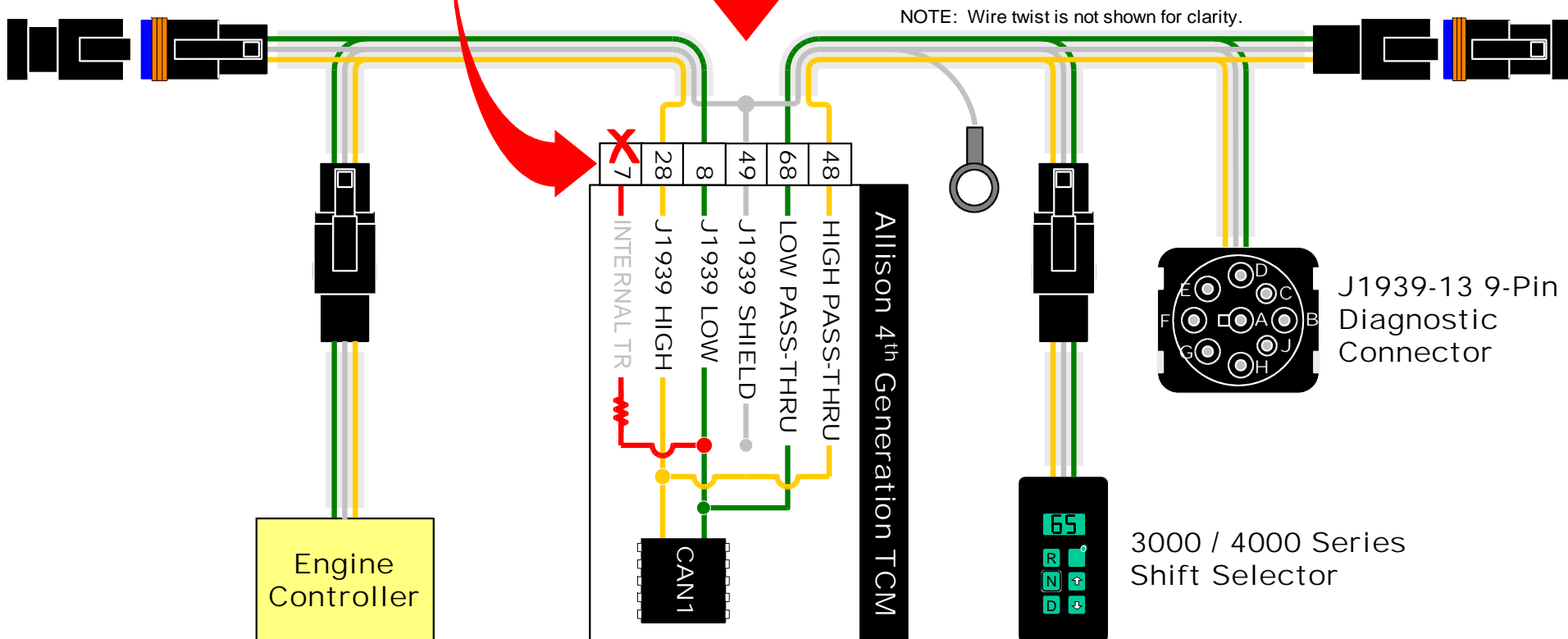

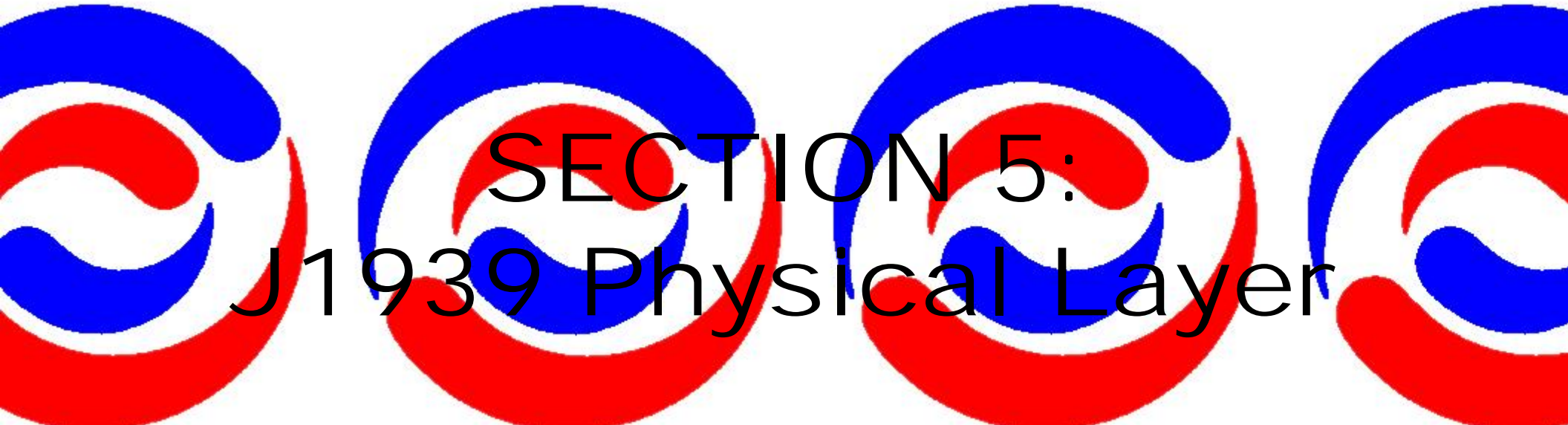

# SECTION 5: J1939 Physical Layer

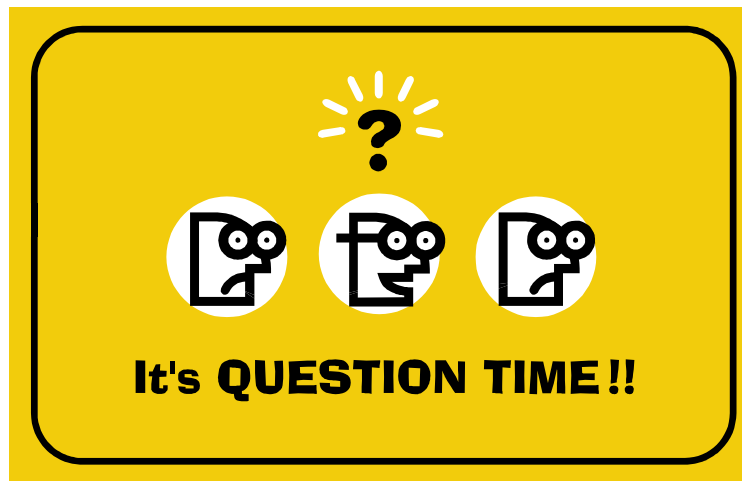

# SECTION 6: Voltage Signals

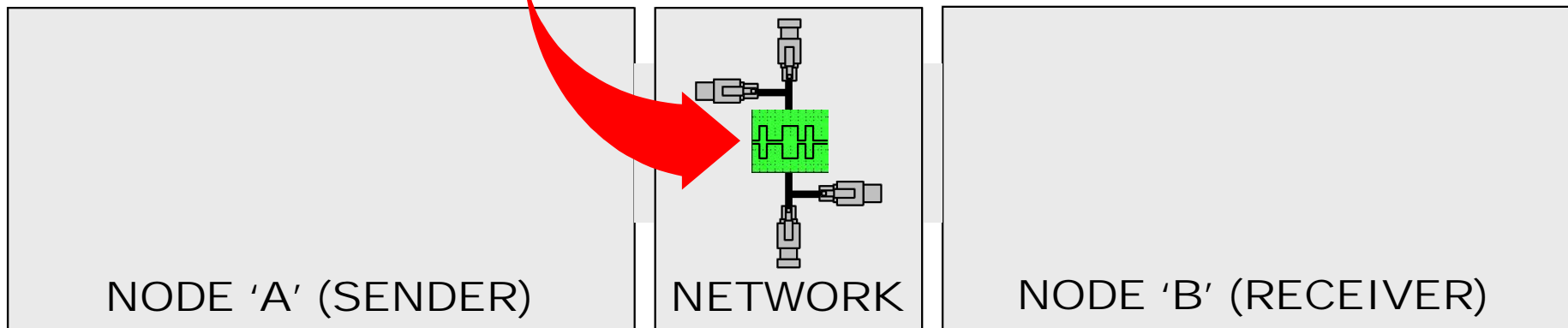



# Oscilloscope View of J1939

Yellow Trace  
Signal lead connected to CAN High (Pin 'A').  
Signal reference connected to ground.

Green Trace  
Signal lead connected to CAN Low (Pin 'B').  
Signal reference connected to ground.

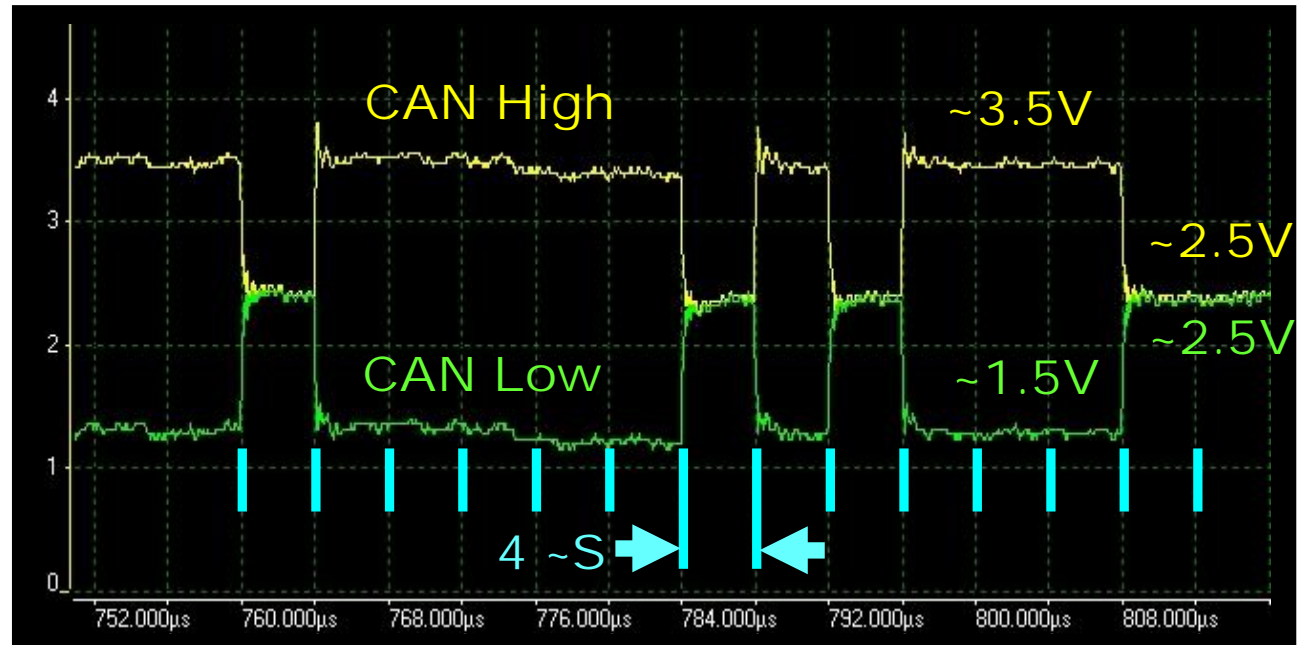

## Characteristics

- CAN High and CAN Low are 'balanced'; when one is 'up', the other is 'down'.
- Voltage changes are low; everything is pretty much  $\leq 1.0$  volt.
- Voltage traces are fairly square, and have only two 'states'.
- These 'state changes' occur at 4  $\mu$ S intervals.

K. Karch – 2005 J1939 Training



# Balanced Signal Concept

Why are CAN High & CAN Low 'balanced'?

- **Electromagnetic Interference** is generated by sharp, fast edge changes in voltage. Edges create magnetic waves that can interfere with other electronic components.
- **Balanced systems reduce these emissions.** With signals on each wire nearly equal but opposite, the radiated signals tend to cancel each other out.
- Ideally, the signals on each wire are exact opposites. However, this is impossible -- both wires can't occupy the exact same physical space. The best scenario is to keep the wires as close to each other as possible.

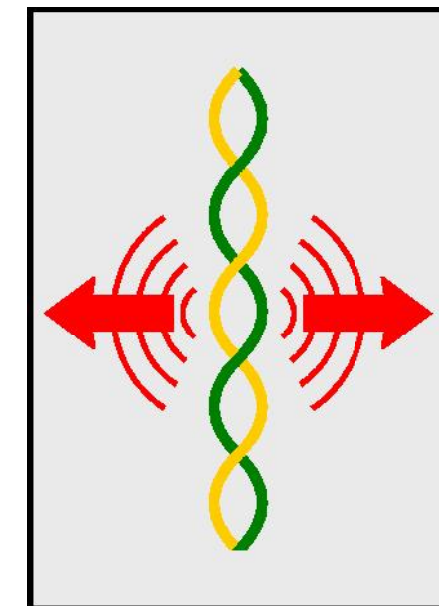
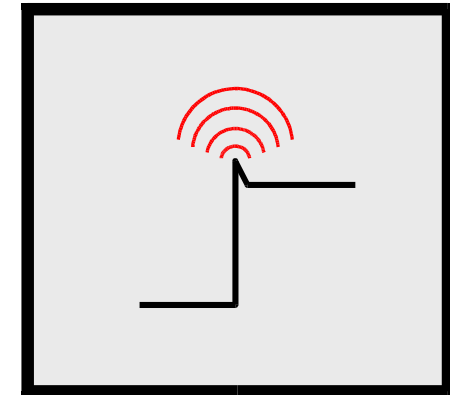

Why are the CAN voltage levels so low?

- Low level voltages also help keep radiated emissions to a minimum. The lower step change in voltage reduces the amount of overshoot seen in the rising edges.



# Differential Voltage

The 'balanced system' approach used to **prevent** radiated EMI can be manipulated to reduce datalink susceptibility to **incoming** EMI.

When voltage traces from the link are processed, CAN Low is subtracted from the CAN High signal to come up with a DIFFERENTIAL VOLTAGE, which defines the bus states.

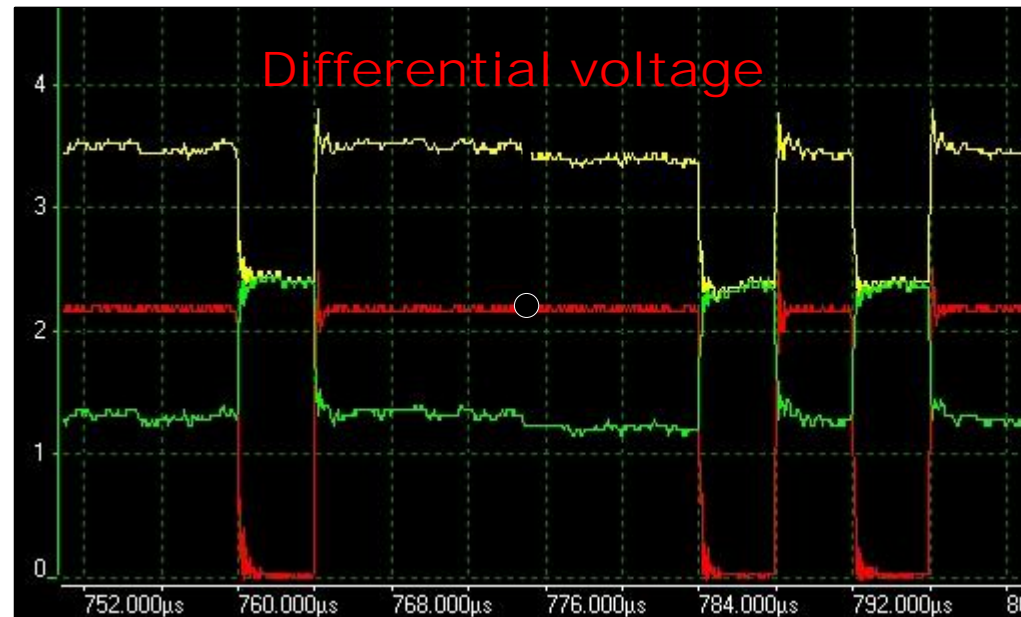

J1939 wiring is a twisted pair, so any electrical noise hits CAN High & CAN Low *at almost the exact same time*. By subtracting the voltages, noise on the wires is subtracted out. The resulting differential voltage trace is much smoother than the traces of either individual CAN wire.

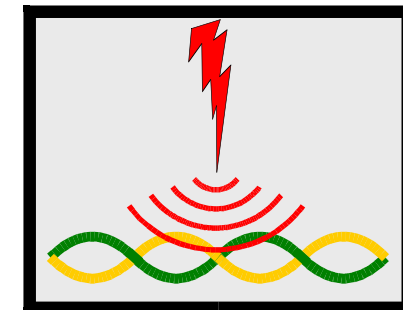



# Bus States

The datalink voltage is BINARY; it consists of two parts or components.

A bus is in a DOMINANT state when the transport media is being activated -- for wires, this means a voltage is being applied. When voltage is not being applied, or the datalink is idle (no activity), the bus is in a RECESSIVE state.

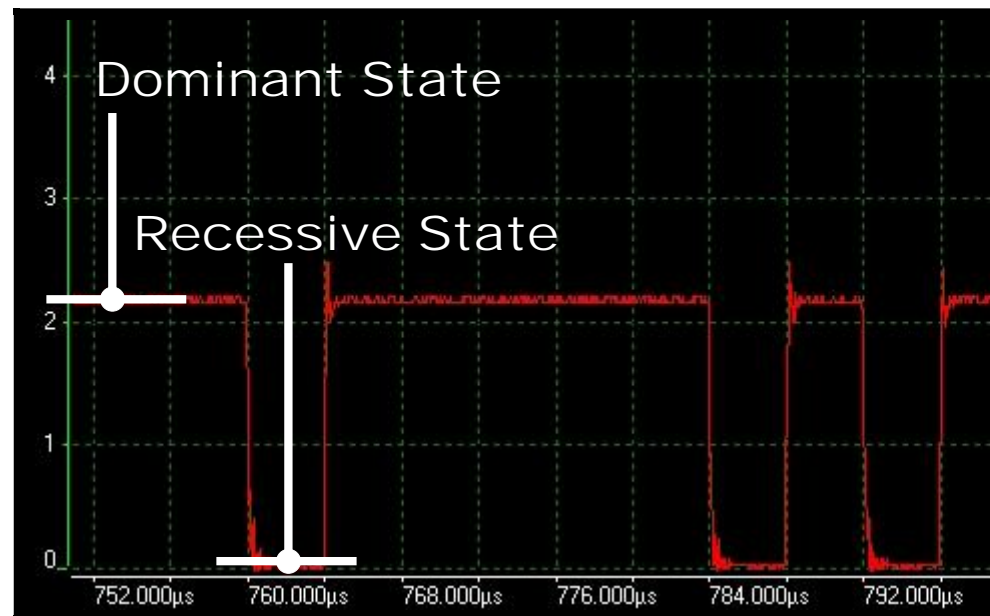

Binary systems can be described by BINARY NUMBERS – 0 or 1. Binary numbers just happen to be well suited for computers, since many electrical devices have just two states – on or off.



# Baud Rate and Bits

**BAUD RATE** – Speed at which information can be transferred. Expressed as the maximum number of state transitions per second (bits per second).

**BIT** – Short for 'binary digit'. Smallest piece of information used by a computer.

J1939 runs at 250 kbps, so up to 250,000 bits of information can be shared each second. The width of a single bit is  $1 \text{ bit} \div 250,000 \text{ bits per second}$  or  $4 \mu\text{S}$ .

Looking at an oscilloscope trace:

Each tick mark on our scope represents  $4 \mu\text{S}$ , so the trace between tick marks is a bit.

Assigning '0' to each dominant bit and '1' to each recessive bit, we end up with a STRING OF BINARY DATA, which is what computers use to communicate.

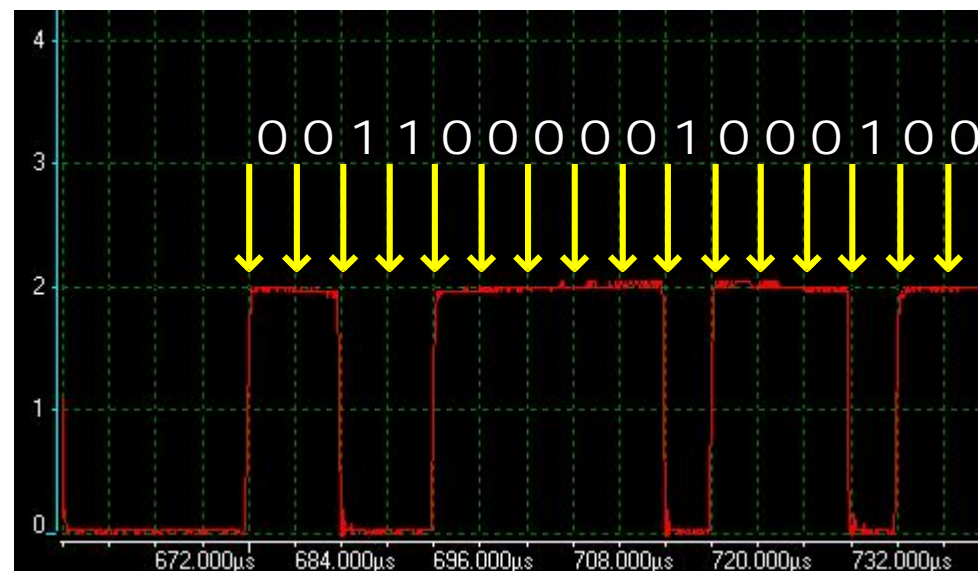



# Connecting to the Datalink: CAN Transceiver

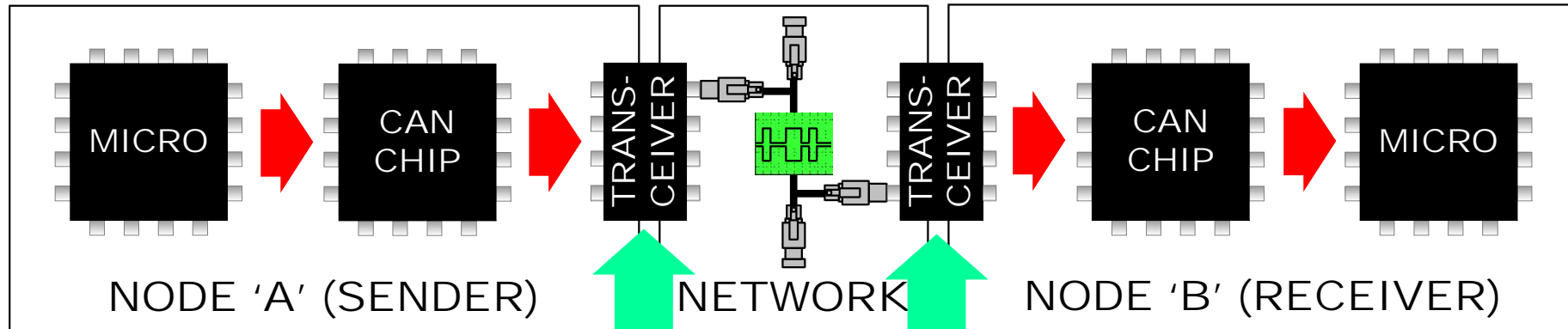

**CAN TRANSCEIVER** – A device that performs both transmitting and receiving functions. The transceiver is a node or controller's connection to the outside world.

- During broadcast, transceivers are fed the bits to be sent, and they 'shape' them. They may trim or 'round off' the edges of bit state transitions in order to reduce EMI radiation.
- During reception, transceivers are the first stop beyond the datalink pins on the controller... A layer of 'protection' between errant voltages and the CAN chip.



# SECTION 6: Voltage Signals

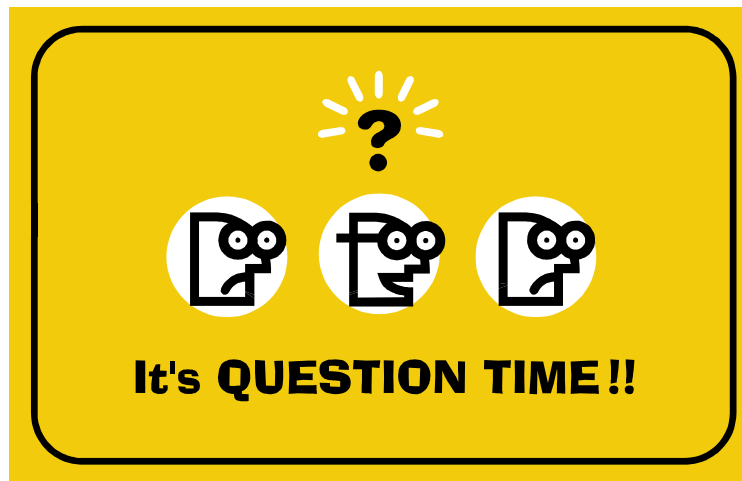

# SECTION 7: CAN Chip & Protocol

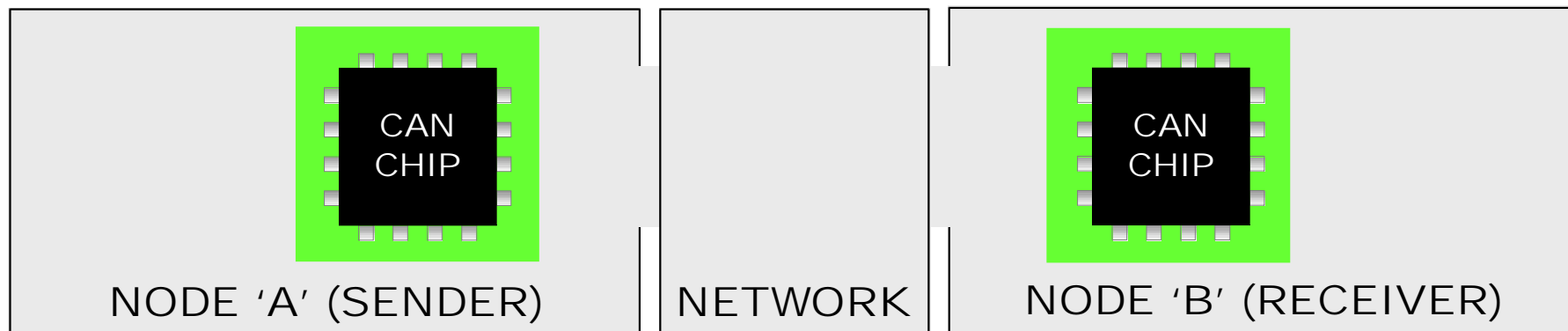



# CAN Overview

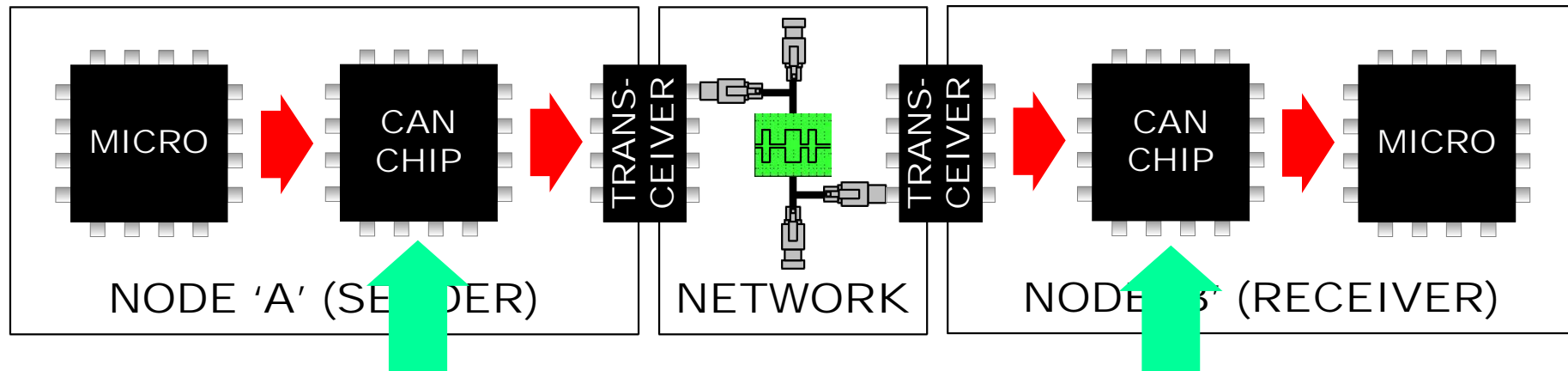

CAN (Controller Area Network) – A chip-imbedded low level protocol which uses a stringent set of rules to handle and ensure communication.

- CAN chips do the 'dirty work' of serial communication, ensuring that any node's message is properly sent to & received by ALL other network nodes.
- Basis for many different networks used in automobiles, heavy trucks, marine, trains, agriculture, construction, medical, manufacturing...
- CAN is a building block – to make a functional network, a higher level protocol is needed. J1939 is one of those protocols.

K. Karch – 2005 J1939 Training



# CAN Chips Do Good Things!

PROVIDE A BASIC MESSAGE FRAMEWORK



**CAN DATA FRAME** – Group of ordered bit fields used to convey data. Like an empty box or envelope used for delivering information.

A typical CAN data frame is 143 bits long, we really only care about the 29-bit identifier (think of a blank shipping label) & the 64-bit data field. J1939 defines these areas further.

ARBITRATE MESSAGES

On a serial communication link, only one person can talk at one time. Using a 'priority' specified in every J1939 message, CAN makes sure:

...the most important message gets on the link first.

...messages are arbitrated 'on the fly', with no additional delay or destruction.

ENSURE SYSTEM-WIDE DATA CONSISTENCY

Through error detection, signaling and management, CAN chips ensure that

**nobody** receives a corrupted message.



# System-Wide Data Consistency

- CAN chips ensure that ANY controller's message is properly received by ALL controllers on the network.
- Every CAN chip in every controller...
  - ⇒ Actively participates all bus activity.
  - ⇒ Receives a copy of *every* message.
  - ⇒ Acknowledges reception of every valid message, *regardless of the parent controller's interest.*
  - ⇒ Forces bad messages to be re-broadcast.
- **EVERYBODY** has access to good messages when **ALL** CAN chips agree it was transmitted correctly,
- **NOBODY** has access to a message if just **ONE** CAN chip says there was something wrong with it.
- CAN ensures messages are received as sent; it does not ensure that the right information was sent!

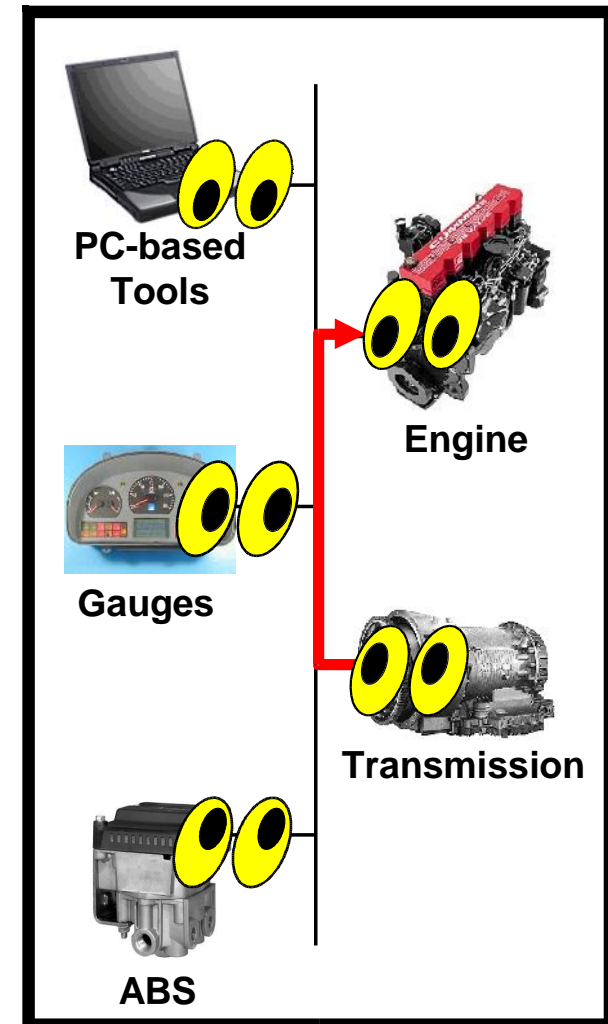



# CAN-Based Datalink Failure Modes



- The CAN chip's ability to detect & reject corrupt messages makes CAN-based system failures different than those using analog or 'hard-wired' connections:

ANALOG – A properly generated analog electrical signal may be corrupted on the way to the receiver by such problems as electrical noise or shorts to ground or power. This corruption **may or may not** affect the value received.

CAN – Wiring problems **cannot** change the values being sent; they can only PREVENT them from arriving at their destination.

- CAN protocol ensures a message is only accepted EXACTLY as the sender generated it. Messages affected by noise or wire faults are rejected.
- When a message is rejected, the CAN chip sends out an:

**ERROR FRAME** – A special series of bits sent out by a CAN chip when it detects that a message has been corrupted. An Error Frame will cause all CAN chips on the network to reject that message.



# CAN Chip & Protocol: Summary

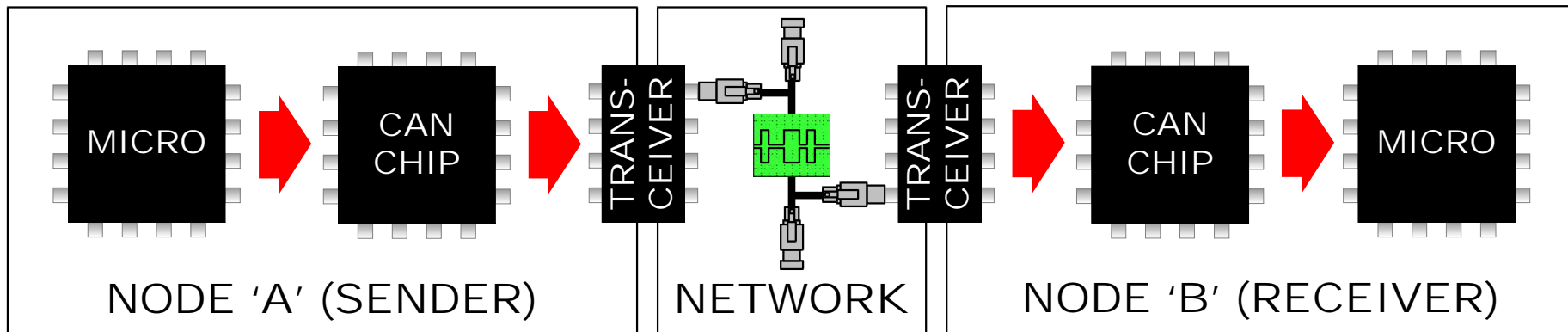

- If a message is sent by one CAN chip and received by another, and neither detect any sort of error during the process...
- It's virtually GUARANTEED that the message was received EXACTLY as generated by the sender. 
- *The odds of a J1939 bit state error going undetected during the transfer process are about 3.1 trillion to 1, or 1 'bad' bit in 400 years of operation!*

# SECTION 7: CAN Chip and Protocol



# SECTION 8: 4<sup>th</sup> Gen TCM Datalink Connections

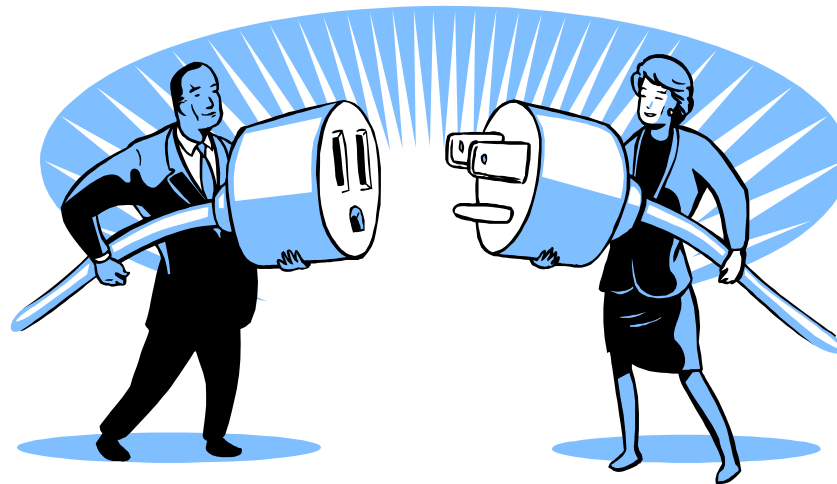



# MY06 Datalink Connections

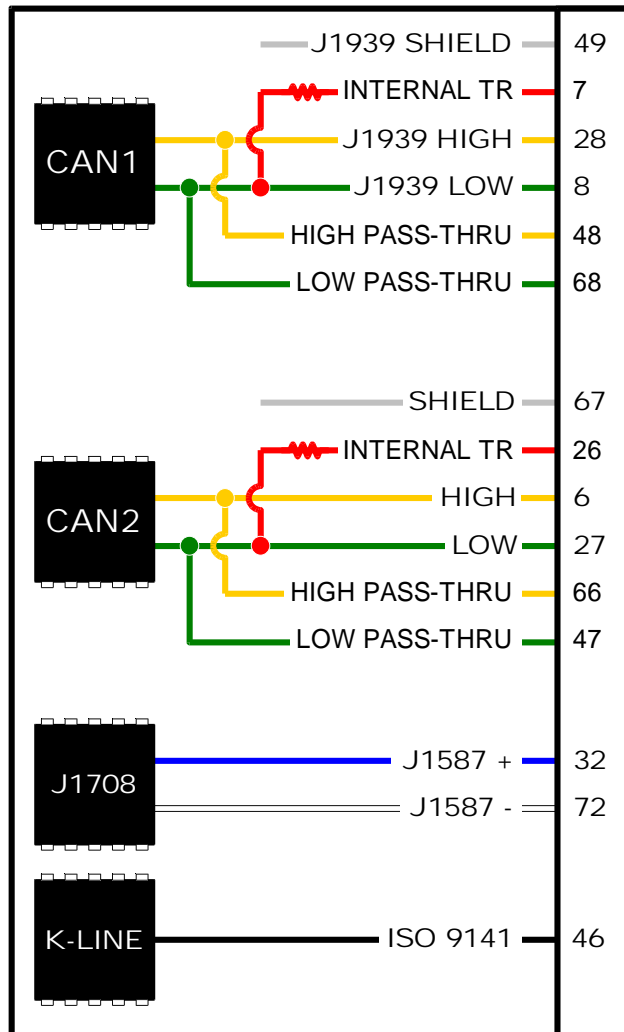

250 Kb CAN link for J1939 and Allison DOC.



500 Kb CAN link for Allison DOC ONLY.



J1587 on WT ONLY. Requires A42 or A43 TCM.



ISO 9141 requires A43 TCM.

K. Karch – 2005 J1939 Training



# COMMUNICATION PROTOCOL Availability vs. TCM Connection

PROTOCOL – Hardware & Speed, message structure, message content (parameters)

PHYSICAL LAYERS AVAILABLE (CONNECTION POINTS)	TCM MODELS THAT SUPPORT THESE PHYSICAL LAYERS	AVAILABLE COMMUNICATION PROTOCOLS	TRANSMISSION SERIES	
			1000 / 2000	3000 / 4000
CAN1: SAE J1939 – 250 Kb	All TCMs	SAE J1939 Only	YES	YES
CAN2: SAE J2284 – 500 Kb	All TCMs	GMLAN Only	YES	YES
J1708 – 9600 baud	A42 and A43 TCMs Only	SAE J1587	NO	YES
K-Line – 9600 baud	A43 TCM Only	ISO 9141	YES	YES



# MY06 Datalink Connection Use

SPECIFIC ITEMS TO BE CONNECTED		ACCEPTABLE TCM CONNECTIONS			
		CAN1 SAE J1939	CAN2 SAE J2284	J1708 SAE J1587	K-Line ISO 9141
J1939-Based Shift selectors	■ Allison manufactured	YES	NO	NA	NA
	■ Vehicle OEM manufactured	YES	NO	NA	NA
Termination Resistors	■ Allison TCM Internal	YES	YES	NA	NA
	■ Allison Shift Selector Internal	YES	NO	NA	NA
Service Tools	■ Allison DOC™	YES	YES	NO	NO
	■ OEM Service	YES	YES	NO	YES
Diagnostic Connectors	■ SAE J1939-13 9-Pin	YES	NO	YES	NO
	■ SAE J1962 (ISO 15031-3 Trapezoidal)	NO	YES	NO	YES
	■ Other OEM-specified	YES	YES	YES	YES



# SECTION 8: 4<sup>th</sup> Gen TCM Datalink Connections

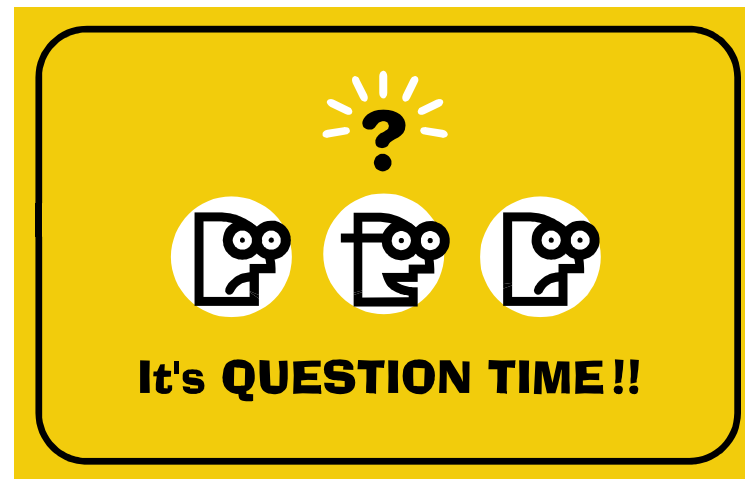

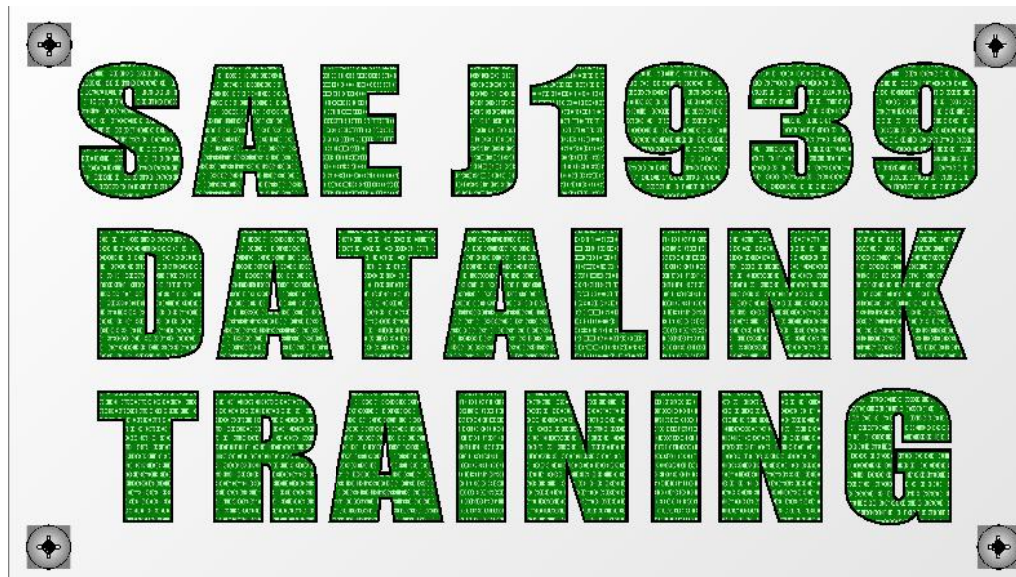

## SESSION TWO

**KEVIN KARCH**  
**ELECTRONIC INTEGRATION**  
**MAY 10<sup>TH</sup> – 11<sup>TH</sup>, 2005**

# SECTION 9: J1939 Communication Protocol – Messages & Parameters

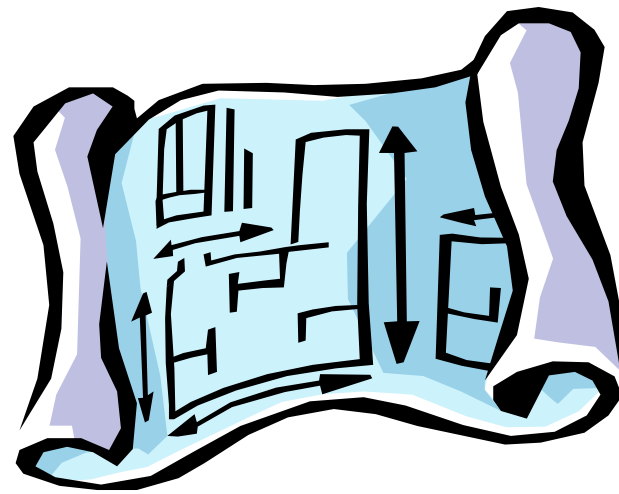



# J1939 Communication Protocol

MICROPROCESSOR – The brains of a controller; run by software & calibrations.

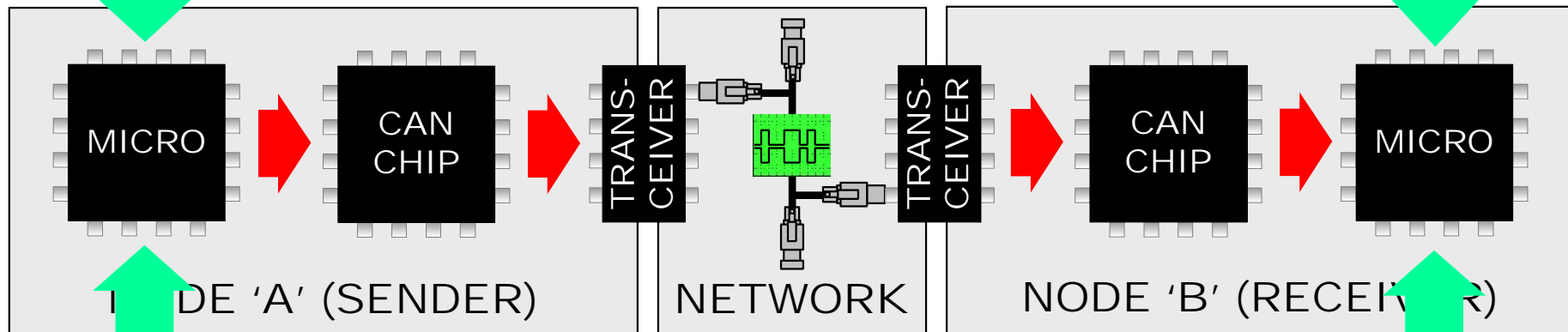

J1939 – Complete definition of a high speed communications network to support real-time closed loop control functions between electronic control devices which may be physically distributed throughout a vehicle.

- CAN provides robustness in terms of getting information from one place to another; however, it provides little definition as to the content.
- J1939 *defines, refines or restricts* the generic capabilities of CAN data frames.



# J1939 Messages ( PGNs )

MESSAGE or 'PGN' (Parameter Group Number) – Collection of J1939 parameters that are specified by information within the 29-bit identifier. May consist of one or more CAN data frames in length.

Message broadcast rates vary, and some messages may support more than one:

- 'Continuous Broadcast' – Messages that go out at a fixed rate, like every 100 ms or every 5 seconds.
- 'On Request' – Only sent when someone asks for the message. These are often larger message that convey information that doesn't change 'on the fly'.
- 'Intermittent Broadcast' – Only sent when necessary, which may be event or request driven.

Messages can also have different destinations:

- 'Global' – Message & contents are for anyone's use.
- 'Destination Specific' – Intended for a specific component.

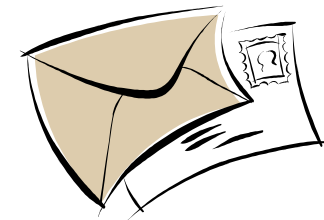



# J1939 Parameters ( SPNs )

- Every message contains a set of parameters defined by SAE.

**PARAMETER** – A specific piece of information conveyed in a PGN.

- For example, this could be a speed, a temperature, a switch state, or a command from one controller to another.
- Parameters are what we really care about. Messages are simply the way parameters get around.

**SUSPECT PARAMETER NUMBER (SPN)** – Identifies an item for which a J1939 diagnostic code may be reported.

- All parameters are assigned an SPN (ex: SPN 597 – *Brake Switch*), but not all SPNs assigned to a parameter.
- ‘Parameter’ and ‘SPN’ are used interchangeably.



# J1939 Parameter Values

SAE defines TRANSMITTED VALUE RANGES which divide up available bit values for a parameter into several specific uses:

- ✓ **VALID RANGE** – Contains data known to be accurate by the component broadcasting the parameter.
- ✓ **PARAMETER SPECIFIC INDICATOR & Reserved** – Relevant information that can't be conveyed within the bounds of the parameter's scaling. (For example, the parameter *Selected Gear* contains numeric values such as 1,2,3, but has PSI 251 defined as 'Park').
- ✓ **ERROR** – The parameter is supported by the component broadcasting it, but that component currently can't determine an accurate value. This typically traces back to a sensor failure. For example, if our sump temperature sensor fails, we indicate 'error' in our TF *Transmission Oil Temperature* broadcast.
- ✓ **NOT AVAILABLE** – Parameter is not supported by the message sender.



# J1939 Addressing

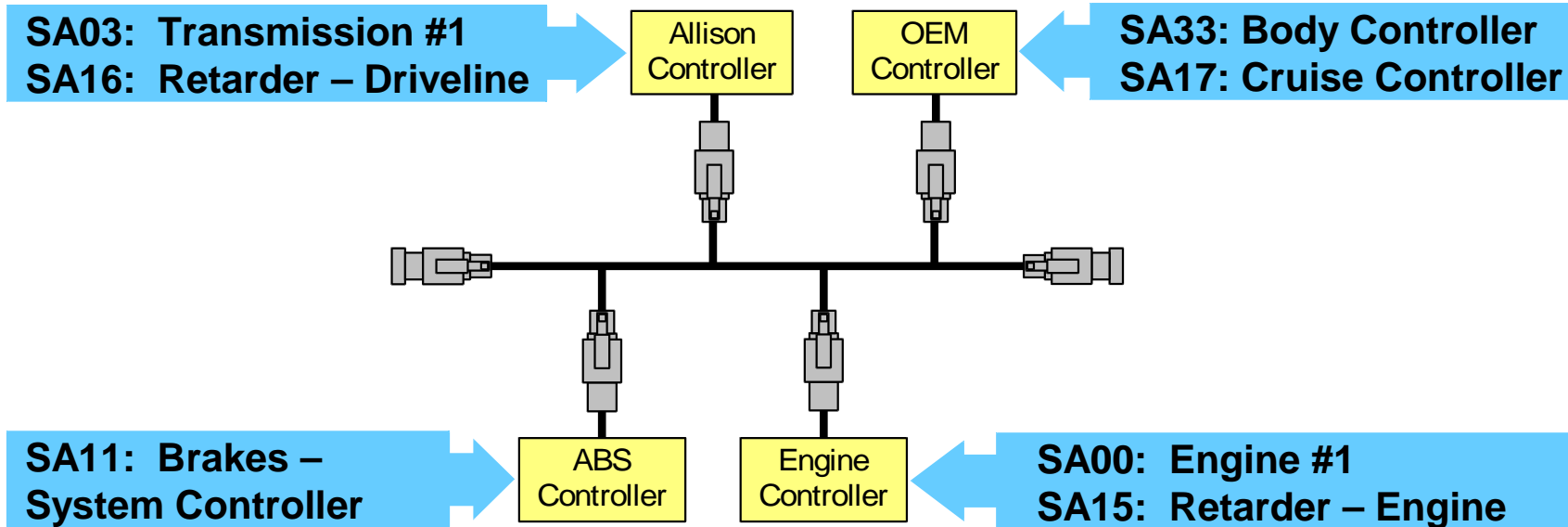

- Source Addresses not based on physical controllers, but on functional entities.
- One node (physical controller) may use several SA's based on its functions.
- Source Addresses may also be used as Destination Addresses:

**DESTINATION ADDRESS (DA)** – Specific address to which a J1939 message is sent; any other devices should ignore this message. The global destination address is 255.

K. Karch – 2005 J1939 Training