

Third Party J1939 Device Installation

© 2016 PACCAR Inc. - All Rights Reserved

This manual illustrates and describes the operation of features or equipment which may be either standard or optional on this vehicle. This manual may also include a description of features and equipment which are no longer available or were not ordered on this vehicle. Please disregard any illustrations or descriptions relating to features or equipment which are not on this vehicle. PACCAR reserves the right to discontinue, change specifications, or change the design of its vehicles at any time without notice and without incurring any obligation. The information contained in this manual is proprietary to PACCAR. Reproduction, in whole or in part, by any means is strictly prohibited without prior written authorization from PACCAR Inc.

Contents

Chapter 1: Introduction.....	5
Introduction.....	6
J1939 Wiring Background.....	6
J1939 Customer Devices.....	6
Best Practices.....	7
Chapter 2: Procedures.....	9
How to Install J1939 Device?.....	10
How to Resolve Multiple Resistor Issue.....	10
Chapter 3: Diagnostics.....	11
How to Test the Vehicle Network for too many Resistors?.....	12
How to Determine if a Customer Device has a Resistor?.....	12
Glossary.....	13

Chapter 1 | INTRODUCTION

In this Chapter:

Introduction.....	6
J1939 Wiring Background.....	6
J1939 Customer Devices.....	6
Best Practices.....	7

Introduction

Ensure that the device being installed is J1939 compatible.

WARNING!

The J1939 databus is the communication link between the engine, automated transmissions, Anti-Lock Brake System (ABS), or other collision mitigation systems. Only J1939 compatible devices should be added to the databus. Even if advertised as being J1939 compatible, some aftermarket devices may disrupt the ability of the databus to communicate. This may cause the factory installed devices to not function properly and may increase the risk of collision, personal injury or death. If the databus is disrupted by an aftermarket device, it must be removed from the databus.

In spite of this warning, PACCAR is aware that these unauthorized devices are being installed on our vehicles. This is an industry wide issue as many of these post-production manufacturers have an incomplete understanding of the effects their devices have on the J1939 CAN network and the factory installed devices on the network. The purpose of this document is to provide general advice regarding best practices for installing aftermarket devices on the J1939 CAN network but makes no guarantees that the device will not affect the network negatively. PACCAR assumes no responsibility for damage caused as a result of applying the recommendations contained in this document. Each vehicle is custom-built, and in the case of incomplete vehicles, the final vehicle manufacturer is an entity other than PACCAR.

J1939 Wiring Background

The J1939 network allows the electronic controllers (ECUs) on the truck to share control commands and data with each other in an orderly manner. The control commands enable the vehicle to perform complex actions such as automated transmission shifting. Data sharing allows gauges and displays to show current information on the dash. In order for the ECUs to communicate properly the network architecture must comply with the requirements as defined by the Society of Automotive Engineers (SAE) J1939 standard.

One of the many requirements is that the entire network can only have two “terminating”

resistors; one on each end of the network. Each resistor must be 120 Ω in order to maintain 60 Ω across the network. If an additional resistor is present, or removed, then the ECUs on the network will not communicate properly. This often results in network “timeouts” and fault codes. The driver might experience harsh automated shifting, radar based cruise control drop-outs and other loss of functionality as a result of system timeouts. Dash warning lamps will turn on if a network device is not able to send or receive data, cannot perform its task for the vehicle, and transmits a fault code.

NOTE

This vehicle may have more or less ECUs depending on how it was ordered.

Kenworth and Peterbilt [Vehicle Controller Area Network \(VCAN\)](#) are designed and manufactured with (2) 120 Ω resistors. One resistor is always present inside the [Cab Electronic Control Unit \(CECU\)](#) located behind the dash. The other resistor is located either inside the PACCAR MX engine ECU or in the engine harness connector outside of a Cummins and PACCAR PX engine ECU.

Factory Built J1939 Network with PACCAR MX ECU

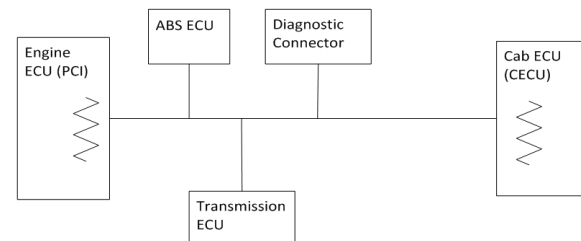

Symbol for Terminating Resistor =

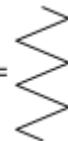

J1939 Customer Devices

Customers often have requirements to install their own devices on the J1939 network. Most often this is a telematics device that will transmit data to the back office for fleet management and service needs. These devices are usually gathering data from the system to report or display.

Best Practices

Kenworth and Peterbilt vehicle CAN networks are designed to comply with SAE J1939 requirements and there are predefined areas for customers to connect their own devices. These best practices are provided to help produce a quality modification regardless of where the device is connected into the network.

Compatible Devices

Ensure that the device being installed is J1939 compatible.

 WARNING!
<p>The J1939 databus is the communication link between the engine, automated transmissions, Anti-Lock Brake System (ABS), or other collision mitigation systems. Only J1939 compatible devices should be added to the databus. Even if advertised as being J1939 compatible, some aftermarket devices may disrupt the ability of the databus to communicate. This may cause the factory installed devices to not function properly and may increase the risk of collision, personal injury or death. If the databus is disrupted by an aftermarket device, it must be removed from the databus.</p>

Devices with an Internal Resistor

Make sure that the device being installed will maintain the J1939 requirement for maximum of (2) resistors on a network. If the device has an internal resistor, the vehicle network will not work properly without extra modifications to the network.

- [How to Determine if a Customer Device has a Resistor?](#) on page 12
- [How to Resolve Multiple Resistor Issue](#) on page 10

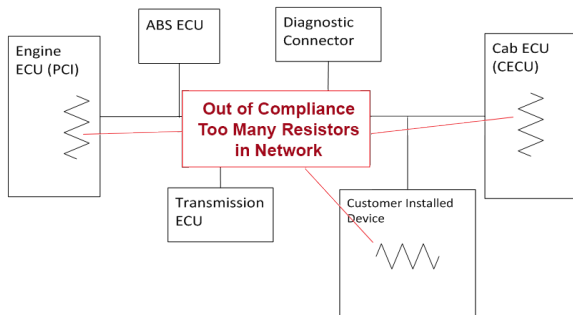

Aftermarket Connection Points

The vehicle manufacturer can provide connections points for some aftermarket body and remote throttle installation, if specified on

the order. PACCAR cannot recommend or endorse using the diagnostic connector for third party installations.

Inline Network Connection

Alternatively, the device can be connected to the network and not through a manufacturer provided connection point.

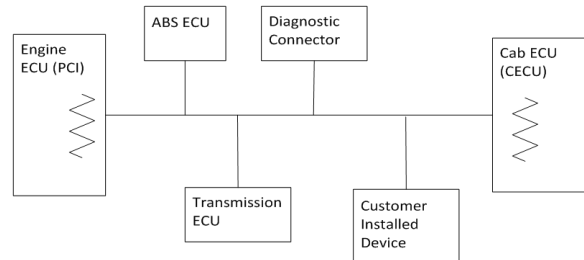

This would involve building a "T" harness that can be connected inline to an existing J1939 **VCAN** connector. This method does not involve cutting wires or compromising wire insulation.

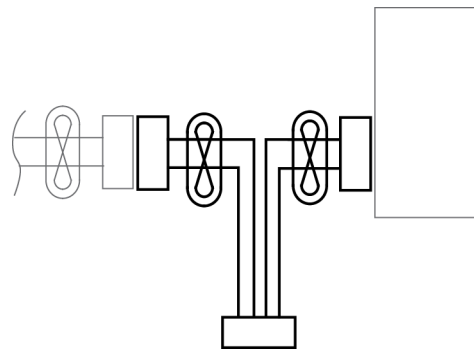

Splicing into J1939 Wires

 NOTE
<p>Splicing into the J1939 network wires voids the original equipment manufacturer's warranty.</p>

 WARNING!
<p>Do not cut or tap into J1939 databus wiring. Doing so will change the resistance in the J1939 circuit which may disrupt communications with the engine, automated transmissions, Anti-Lock Brake System (ABS), or other collision mitigation systems. This may cause these devices to not function properly and may increase the risk of collision, personal injury or death. Only use approved J1939 components with validated software.</p>

Avoid splicing directly into network wires. However, the vehicle manufacturer has the following guidelines (Quality Wiring Installation) in the event where splicing into a network wire is unavoidable.

- Splices should be made with automotive quality butt splices.
- Do not use insulation-displacement or “Scotch Lock” style connectors to connect new wires to the vehicle network wires. These will not maintain good connectivity with the network.
- Do not use residential wire nuts or “twist and tape” methods to join wires.
- Use automotive grade sealed connectors and splices for any wiring modifications made outside the cab, including under hood.

Chapter 2 | PROCEDURES

In this Chapter:

How to Install J1939 Device?.....	10
How to Resolve Multiple Resistor Issue.....	10

How to Install J1939 Device?

Read all recommendations in [Best Practices](#) on page 7.

1. Determine if the device is J1939 compatible.
2. Determine if the device is recording data from the network or if it will interact with other ECU's.
3. Determine if the device has its own terminating resistor.
 - [How to Determine if a Customer Device has a Resistor?](#) on page 12
 - If the J1939 device has its own terminating resistor; be sure to complete the network wiring modifications as explained [How to Resolve Multiple Resistor Issue](#) on page 10.
4. Define where in the Cab the device will be installed and where in the network it will have to be connected.

If the device is not going to be installed using a "T" harness, be sure to follow all guidelines for Quality Wiring Installation ([Best Practices](#) on page 7).
5. Proceed to install the device and connect to the CAN network.

Validate that there is only 60 Ω across the network. [How to Test the Vehicle Network for too many Resistors?](#) on page 12.

How to Resolve Multiple Resistor Issue

If the device has a resistor, you can still install it but you must remove one of the existing resistors from the network. The best place to do this is to move a pin on one of the [CECU](#) connectors from the network.

1. Access connector **D** on the [CECU](#), which has the wires for [VCAN](#)
2. Relocate the wire and pin from location 40 to the open position 38.

NOTE

If pin 38 is already populated with an existing pin, tie back pin #40 and isolate it properly.

NOTE

The connector shell has the number molded on the mating face for reference.

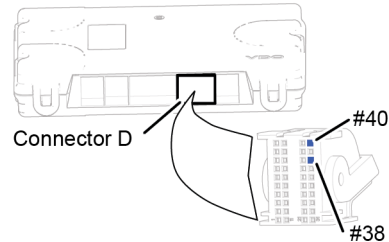

Verify that the system has only 60 Ω at the diagnostic connector [How to Test the Vehicle Network for too many Resistors?](#) on page 12.

Device with Resistor Installed and CECU Resistor Removed

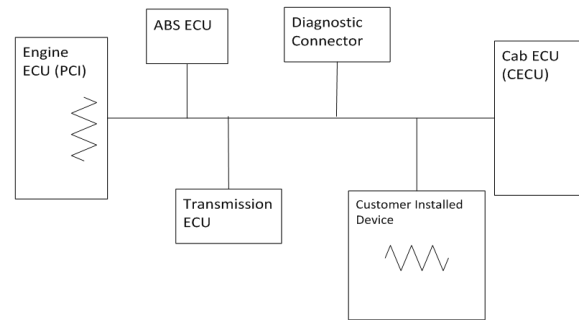

Chapter 3 | DIAGNOSTICS

In this Chapter:

How to Test the Vehicle Network for too many Resistors?.....	12
How to Determine if a Customer Device has a Resistor?.....	12

How to Test the Vehicle Network for too many Resistors?

A network can only contain 2 terminating resistors. Follow these steps to identify if the network has the correct number of resistors in the system.

WARNING!

Do not modify the vehicle network in such a way that changes the overall network resistance. Changing the resistance in the J1939 circuit may disrupt communications with the engine, automated transmissions, Anti-Lock Brake System (ABS), or other collision mitigation systems. This may cause these devices to not function properly and may increase the risk of collision, personal injury or death.

1. With a basic multimeter; set its mode to **Resistance Measurement** (typically identified by the Ω symbol)
2. Measure across the J1939 + and J1939 – pins of the 9-pin diagnostic connector on the dash.

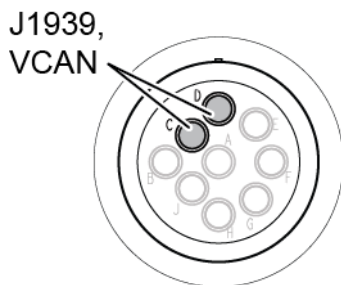

The resistance for the entire network should be about 60 ohms.

- If greater than 60 Ω (ohms), there are not enough resistors in the network. [How to Determine if a Customer Device has a Resistor?](#) on page 12
- If less than 60 Ω (ohms) there are too many resistors in the network. Evaluate the network to ensure all resistors are where they are supposed to be.

How to Determine if a Customer Device has a Resistor?

Some J1939 devices have a terminating resistor in them. Installing a device and not knowing if it has a resistor can affect the vehicle's network performance.

WARNING!

The J1939 databus is the communication link between the engine, automated transmissions, Anti-Lock Brake System (ABS), or other collision mitigation systems. Only J1939 compatible devices should be added to the databus. Even if advertised as being J1939 compatible, some aftermarket devices may disrupt the ability of the databus to communicate. This may cause the factory installed devices to not function properly and may increase the risk of collision, personal injury or death. If the databus is disrupted by an aftermarket device, it must be removed from the databus.

1. With a basic multimeter; set its mode to **Resistance Measurement** (typically identified by the Ω symbol)
2. Measure across the device's J1939 + and J1939 – pins.
 - Devices with a terminating resistor will read 120 Ω on a multimeter. If the device has a resistor, the network will need additional modifications. See [How to Resolve Multiple Resistor Issue](#) on page 10.
 - Any other reading indicates that the device does not have a terminating resistor. No other modifications to the network will be required.

Glossary

Vehicle Controller Area Network - Vehicle data network as defined by SAE J1939

Cab Electronic Control Unit - Control unit for cab network devices