

Printed By: MARK HARRISON

**Service**

Chassis ID

Path

875/Diagnostics/VN, VERSION2,  
L5H4 (780 CAB), PH-CAB (CAB  
PARKING HEATER)/Parking Heater,  
Fault Tracing

Model

Identity

VN

84977628

Publishing Date

Operation No.

Tuesday, February 21, 2006

## Webasto Parking Heater, Diagnostics

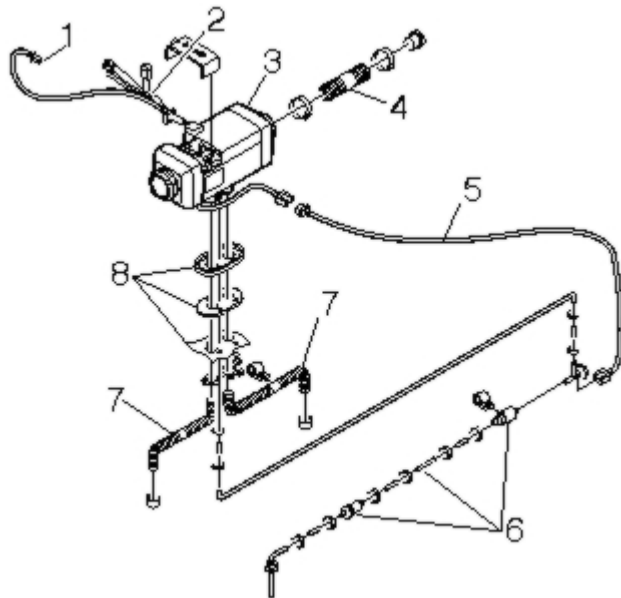

1. Parking Heater Switch Line
2. Harness
3. Heater
4. Air Duct
5. Optional Extension Harness
6. Fuel Pump, Filter and Lines
7. Intake and Exhaust Tubes
8. Bracket Gaskets

Note: The following steps are to be used in making the decision to repair or replace the heater, under warranty conditions.

If the heater is inoperative after following the standard startup perform the following procedures:

### Power System

1

Check the 15 AMP fuse in the LECM.

2

Confirm the heater has battery voltage, at the ECU.

Note: The 14 gauge red wire (pin 2) should read 12 Volts positive.

Note: The 14 gauge brown wire (pin 8) ground wire on heater harness

3

Check all wire connectors for positive connections.

## Fuel System

1

Check the fuel supply line for breaks, kinks, etc. Check all connections to assure clamps are tight and there are no leaks around the connectors.

2

Inspect the filter to ensure fuel is visible and there is no restriction in the filter or fuel tubing.

3

Turn the heater on and listen for a “clicking” sound from the pump. This is the fuel pump and the click indicates proper operation.

4

If no “clicking” sound is heard when the heater is in the “ON” position, check to ensure the pump is receiving pulses of 12 Volts.

5

Check the fuel pump electrical connector. Confirm the connector is secure to the pump.

6

Using a multimeter, back probe the harness connectors for 12 volt pulses. If there is power and there is no obvious clicking sound replace the fuel pump.

7

Disconnect the fuel line at the heater and place the loose end into a container. Turn the heater on and confirm that fuel is pumping. If there is no flow and the pump is clicking go back and check the fuel filter and fuel line for obstructions and continuity.

## Heater and Controls

### ECU

1

If the heater is inoperative and there is power and fuel to the heater check and repair or replace the ECU.

### Temperature Sensor

1

If the heater shuts down in an overheat condition, make sure there is no blockage of the air inlet or outlet grids. Check at the inlet and ensure that there is not a kink or restriction of the ducting. If the

inlet and outlet grids are clear and there is no restriction of the ducting, replace the temperature sensor.

## Unit Replacement

1

If one or more of the listed steps do not correct the problem, replace the heater.